

10  
6-17-93 JSD

LBL-32231  
UC-~~100~~ 221



# Lawrence Berkeley Laboratory

UNIVERSITY OF CALIFORNIA

## ENERGY & ENVIRONMENT DIVISION

### **Transmission Planning in the Era of Integrated Resource Planning: A Survey of Recent Cases**

R. Baldick and E.P. Kahn

September 1992

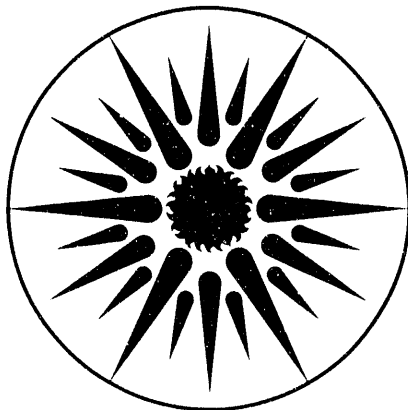

**ENERGY & ENVIRONMENT  
DIVISION**

Prepared for the U.S. Department of Energy under Contract Number DE-AC03-76SF00098

DISTRIBUTION OF THIS DOCUMENT IS UNLIMITED

## DISCLAIMER

This document was prepared as an account of work sponsored by the United States Government. Neither the United States Government nor any agency thereof, nor The Regents of the University of California, nor any of their employees, makes any warranty, express or implied, or assumes any legal liability or responsibility for the accuracy, completeness, or usefulness of any information, apparatus, product, or process disclosed, or represents that its use would not infringe privately owned rights. Reference herein to any specific commercial product, process, or service by its trade name, trademark, manufacturer, or otherwise, does not necessarily constitute or imply its endorsement, recommendation, or favoring by the United States Government or any agency thereof, or The Regents of the University of California. The views and opinions of authors expressed herein do not necessarily state or reflect those of the United States Government or any agency thereof or The Regents of the University of California and shall not be used for advertising or product endorsement purposes.

This report has been reproduced directly  
from the best available copy.

Available to DOE and DOE Contractors  
from the Office of Scientific and Technical Information  
P.O. Box 62, Oak Ridge, TN 37831  
Prices available from (615) 576-8401, FTS 626-8401

Available to the public from the  
National Technical Information Service  
U.S. Department of Commerce  
5285 Port Royal Road, Springfield, VA 22161

Lawrence Berkeley Laboratory is an equal opportunity employer.

# Transmission Planning in the Era of Integrated Resource Planning: A Survey of Recent Cases

*Ross Baldick and Edward P. Kahn*

Energy & Environment Division  
Lawrence Berkeley Laboratory  
University of California  
Berkeley, CA 94720

September 1992

The work described in this report was funded by the Assistant Secretary for Conservation and Renewable Energy, Office of Utility Technologies, Office of Energy Management of the U.S. Department of Energy under Contract No. DE-AC03-76SF00098.

**MASTER**

# Contents

---

	Page
<b>Executive Summary</b> . . . . .	<b>ix</b>
Purpose of this Study . . . . .	ix
Organization of Report . . . . .	x
Typology of Regulatory Issues in Transmission . . . . .	x
Conclusions and Suggestions . . . . .	xiii
<b>Chapter 1 Introduction</b> . . . . .	<b>1</b>
Purpose of this Study . . . . .	1
Organization of Report . . . . .	2
<b>Chapter 2 A Typology of Regulatory Issues in Transmission</b> . . . . .	<b>5</b>
Overview . . . . .	5
Institutional Issues . . . . .	8
Technology Structure . . . . .	14
Decision-Making Complexity: Feasibility versus Optimality . . . . .	32
<b>Chapter 3 Utility Integrated Resource Plans: What Role for Transmission?</b> . . . . .	<b>37</b>
Overview . . . . .	37
Current IRP Practice . . . . .	37
The Larger Setting: Linkages Between IRP and Other Processes . . . . .	41
The Future Challenge . . . . .	43
<b>Chapter 4 Case Studies: State Regulation</b> . . . . .	<b>45</b>
Overview . . . . .	45
Second Devers-Palo Verde Line (DPV2) . . . . .	46
California-Oregon Transmission Project (COTP) . . . . .	52
Kramer-Victor Line (K-V) . . . . .	58
Duquesne Light/GPU Joint Venture (DL/GPU) . . . . .	67
Consumers Power Company-PSI Line . . . . .	71
Synopsis . . . . .	75
<b>Chapter 5 Survey of Selected Transmission Policies at the Utility, State and</b> <b>Federal Levels</b> . . . . .	<b>79</b>
Overview . . . . .	79
Utility Proposals and Frameworks . . . . .	80
State Legislation . . . . .	87
Federally Adjudicated Cases . . . . .	93
Synopsis . . . . .	99

<b>Chapter 6</b>	<b>Technical Analysis in Transmission Planning</b>	<b>101</b>
	Overview	101
	Theoretical Long-Term Transmission Planning Under Vertical-Integration	102
	Transmission Planning by Utilities for Wheeling and Independent Power	106
	Transmission Planning Software Models	107
	Transmission Operations Models	110
	Summary	112
<b>Chapter 7</b>	<b>Conclusions and Suggestions</b>	<b>115</b>
	Generalizations From the Case Studies	115
	Potential Solutions and Suggestions	116
<b>Acknowledgements</b>		<b>120</b>
<b>References</b>		<b>121</b>
<b>Appendix</b>	<b>The Economics of Information and Transmission Regulation</b>	<b>133</b>
	Overview	133
	Market Forces and Natural Monopoly in the Electric System	133
	Survey of Economics Literature on Wheeling	135
	Survey of Economics Literature on Information Asymmetries	137
	Co-ordination Losses in Transmission Planning Under Competitive Generation Supply	139

## List of Tables

Table	Title	Page
ES-1	Summary of Issues that Arise in Transmission Planning . . . . .	xii
2-1	Summary of Issues that Arise in Transmission Planning . . . . .	7
2-2	Benefits of New Radial and Network Capacity . . . . .	17
2-3	Transmission Construction Costs for Example 6 . . . . .	24
2-4	Economics of Over-Building Lines for Example 7 . . . . .	26
2-5	Costs and Break-Even Sales of Capacity for Example 9 . . . . .	29
4-1	Costs and Physical Characteristics of Lines . . . . .	45
4-2	Kramer-Victor Transmission Proposals and Decision Chronology . . . . .	60
4-3	Summary of Economies of Scale in Kramer-Victor . . . . .	64
4-4	Annual Revenues for 500 MW of Transmission Service . . . . .	70
4-5	Case Studies and Issues . . . . .	77
5-1	Issues Treated Coherently by Utility, State and Federal Policy . . . . .	100
6-1	Costs of Transmission Construction . . . . .	104
6-2	Issues Treated Coherently by Software Packages . . . . .	113



# List of Figures

Figure	Title	Page
2-1	Lines, Generator and Loads for Example 1 . . . . .	16
2-2	Transmission Lines in Examples 2 and 3 . . . . .	19
2-3	Transmission Lines in Example 5 . . . . .	22
2-4	Lines and Transformers for Examples 6 and 7 . . . . .	25
2-5	Generators, Loads and Lines for Example 10 . . . . .	32
2-6	Utilities in Example 11 . . . . .	34
2-7	Utilities and Resources in Example 12 . . . . .	35
3-1	External Transmission Connections to Nevada Power Company . . . . .	38
3-2	Transmission Regions in Niagara Mohawk IRP . . . . .	40
4-1	Map of DVP2, COTP and K-V . . . . .	46
4-2	DPV2 Regulatory Analysis Chronology . . . . .	48
4-3	Map of Pertinent Lines in Kramer-Victor Area . . . . .	58
4-4	Map of Duquesne/GPU Joint Venture . . . . .	67
4-5	Schematic Map of CP-PSI Line . . . . .	72
5-1	Potential Routes for Transmission Expansion in Wisconsin . . . . .	89
6-1	Multi-Stage Transmission Planning . . . . .	105
6-2	DFI Representation of Lines . . . . .	108
6-3	SERAM Representation of Lines . . . . .	112



## *Executive Summary*

### **Purpose of this Study**

Electric power transmission system issues are increasingly important as utilities and their regulators evaluate options for:

- expanding the capacity of utility systems, and,
- increasing the competition in the generation sector.

There has been growing interest in this subject, accompanied by a substantial policy debate. The focus of this debate has been primarily at the national level. Yet state action is critical to the expansion of the high-voltage transmission network, because regulated utilities must seek approval from utility commissions for proposals to site new lines. The siting process brings all the policy issues debated in general terms down to case and circumstance specifics.

It is the purpose of this report to survey the regulatory treatment of issues that are unique to or ubiquitous in transmission planning and use. We review recent transmission siting cases to examine how the issues are presented to and resolved by state regulatory commissions and to provide a perspective for more general discussion of transmission policy. Our primary focus is on planning issues. Regulatory approval requires that satisfactory answers be given to the basic question, 'Why should a particular project be built?' This is typically the framework adopted when utilities propose new bulk power capacity additions.

Transmission capacity expansion is not typically treated in integrated resource planning. It is usually assumed that there is adequate transmission to achieve any particular plan. We believe that one important reason for this omission is the inherent complexity of transmission system expansion. It is among the most technically difficult aspects of electric utility planning and operations, relying on detailed technical data. This complexity is exacerbated by conflicts that arise from the increasing competition in the generation sector. This competition leads to conflicts over the use of the transmission system. Unfortunately, handling difficult and detailed technical information in settings of conflict can easily lead to opportunism. Regulators and competitors may be at a serious disadvantage in negotiating or adjudicating specific transmission proposals with utilities, who generally have greater knowledge of both general technological considerations and case specifics. This problem of asymmetric information must be addressed at some level in planning or dispute resolution. However, we will observe that explicit consideration of the information problem is absent from most regulatory and technical analysis of transmission.

The goal of this survey is to share knowledge about the problems facing state regulators over the siting of new transmission facilities, and help to define constructive approaches to them.

## **Organization of Report**

Our study is organized as follows: in Chapter 2, we define a typology of issues that will be used to organize our survey of cases. The typology considers three general categories: institutional, technology structure, and informational complexity. The case studies are divided into three groups. In Chapter 3, we examine the treatment of transmission in utility Integrated Resource Plans (IRPs). We find that current practice of IRP involves a very limited role for transmission issues. These limits are due to the information complexity problem, the regional nature of major transmission projects (as opposed to the state focus of IRP) and other factors. In Chapter 4, we examine transmission construction projects under the jurisdiction of state commissions. Each study highlights one or more of the issues raised in Chapter 2. Collectively, the studies indicate that each of the issues we raise has been left unresolved in practice in some major transmission project.

In Chapter 5 we review a number of initiatives by both private and public organizations for frameworks to resolve transmission issues. They treat both the issues involved with new construction, and also access to existing transmission by third parties. We examine each proposal, legislation, framework, or case from the perspective of the issues described in Chapter 2. We ask: 'if the key points of this initiative were used to assess the transmission projects described in Chapters 3 and 4, then would the issues raised in Chapter 2 be resolved coherently?' We conclude that many perform relatively poorly on various issues; however, combinations of initiatives, particularly combinations of complementary State and regional initiatives, may be able to resolve almost all of the issues simultaneously.

Chapter 6 focuses on the role of complex economic-engineering analysis in transmission planning. We describe state-of-the-art transmission planning, indicate the studies that are actually performed in practice to analyze wheeling transactions by several California utilities, and then survey the software available in the public domain. The discussion of theoretical analysis will indicate the complexity of transmission planning, providing a context for the discussion of practical transmission planning.

Chapter 7 offers conclusions.

## **Typology of Regulatory Issues in Transmission**

Table ES-1 summarizes the list of issues that have been explicitly considered by regulatory agencies in our case studies and also issues that may warrant consideration, but which have not appeared prominently in regulatory discussions to date.

We divide the issues into three major categories: institutional; technology structure; and, decision-making complexity issues. Institutional issues (see Section 2.2) include competition between transmission-owning and transmission-dependent utilities (TDUs) over access to

transmission. We generically call this 'wheeling access.' The most complete consideration of this issue is found at the federal level, in merger conditions (for example, PacifiCorp (see Section 5.4.3)) or as license conditions for nuclear plants (for example, the Central Area Power Coordinating Pool (CAPCO) agreements (see Section 5.4.2)). Competition issues associated with unregulated private producers, which are qualitatively different from inter-utility competition, are treated separately. Our case study of the Kramer-Victor transmission reinforcements (see Section 4.4) illustrates these issues.

Three pervasive institutional problems in the regulation of transmission planning are:

1. Asymmetric regulatory constraints on different types of entities in the utility industry. The governance of municipal and investor-owned utilities differ considerably, and both are distinct from the controls on private producers;
2. The adoption of differing objectives by various regulatory agencies. This problem is magnified by the occasional difficulty in discerning the objectives of regulatory agencies; and,
3. The distinction between pecuniary benefits, which arise from side payments between participants, and real benefits; that is, social efficiencies.

The California-Oregon Transmission Project (COTP) raises all of these issues (see Section 4.3).

Effective regulatory oversight can be constrained by the information asymmetries between regulators and the utilities and amongst utilities. Independent analysis and verification of utility positions is severely constrained by the limited availability of verifiable proprietary information concerning, for example, transfer capacity limits and by the lack of independent technical capability to review studies critically. The problem of information asymmetries is compounded by the lack of standards in assessment of transmission capacity.

A second category of transmission planning issues is inherently tied to technology structure or characteristics (see Section 2.3). We describe the distinctions between radial and network transmission expansion and note that transmission often involves externalities; that is, situations in which the actions of one party have effects on others. Most transmission-related externalities are negative, that is, costs are imposed on third parties; however, in some cases, the externalities are positive. Identifying and assessing the impact of externalities must precede some method to compensate for their effects, or to allocate their costs. Because of jurisdictional boundary issues, the presence of externalities on a regional scale brings into question the ability of state regulation to pose and answer relevant questions in cost/benefit analysis. A related issue is the synergistic effects of combinations of projects.

Economies of scale and economies of scope are also common issues in transmission planning. Both economies stem from the inherently multi-purpose nature of transmission, which serves both multiple generators and loads. These characteristics are intrinsic to transmission projects and present major equity problems in allocating the cost of projects to participants. We assess these issues and also address risk in speculative building of transmission that takes advantage of

**Table ES-1  
Summary of Issues that Arise in Transmission Planning**

Category	Issue	Features
Institutional	Competition	Wheeling Access for TDUs
		Independent Power
	Regulation	Asymmetric Constraints
		State and Regional Conflicts
		Pecuniary versus Real Benefits
	Information Asymmetries	
Standards		
Technology	Line Characteristics	Radial
		Network
	Network Externalities	Negative
		Positive
		Synergies
Structure of Scale	Economies	Intertemporal Allocation
	of	Growth Uncertainties
	Scale	Unsustainability
Economies of Scope		
Decision-Making Complexity	Feasibility versus Optimality	Operations
		Planning
		Operations and Planning

economies of scale. The Duquesne-GPU transmission line proposal raises these questions (see Section 4.5).

The third category of issues stems from the decision-making complexity of transmission planning, which makes it difficult to define an optimal expansion plan (see Section 2.4). Instead, the goal of transmission planning is often feasibility with respect to a set of criteria, including financial viability, rather than optimality. We discuss the feasibility versus optimality issue both in the short term from an operational point of view and also in the long term for transmission construction.

## **Conclusions and Suggestions**

We first consider the tension inherent in transmission planning due to regulation and competition. Under traditional rate of return regulation, profit-maximizing transmission-owning utilities (TOUs) have two apparently conflicting desires:

1. according to the Averch-Johnson model, profit maximization encourages them to over-invest in capital to the extent that it can be rate-based, while,
2. to limit competition from independent producers and other utilities in the generation sector, the utilities are motivated to undersupply transmission service, even if there is excess capacity available.

As we demonstrate in the Kramer-Victor and COTP case studies, these goals are not necessarily incompatible:

- In Kramer-Victor, the utility was given PUC approval to invest in and ratebase considerable transmission in excess of that needed by Qualifying Facilities (QFs), but also limited the control and ownership of lines by the QFs.
- In COTP, it is possible that the Pacific Intertie capacity could have been increased much more economically by expansion remote from the Pacific Northwest, while the IOUs wanted to limit the Pacific Intertie capacity owned by competitors.

These examples illustrate the potential problems in a regulated monopoly interacting with unregulated participants or participants bound by different regulatory constraints. The Duquesne/GPU project also combines elements of regulated and unregulated ventures. The contractual arrangements of the Duquesne/GPU project may be able to avoid some of the institutional conflict that has arisen in the California Case Studies.

Secondly, we discuss information asymmetries. In Devers-Palo Verde 2 (see Section 4.2) and to a lesser extent Kramer-Victor, regulatory proceedings relied on considerable information that was private to the utility and which only gradually, if ever, became public knowledge. The issue of private information is central to transmission.

The initiatives discussed in Chapter 5 are all potential candidates for solving the problems raised by the case studies in Chapters 3 and 4. None of the initiatives address all the issues; however,

combinations of several of them could collectively address them all. A promising model is the Wisconsin Advance Plan (WAP) (see Section 5.3.1), but the success of the WAP depends on:

1. comprehensive jurisdiction in Wisconsin; and,
2. relatively equal competitive positions among the utilities that effectively discipline them to truthfully reveal their characteristics.

The Public Service Commission of Wisconsin's (PSCW's) comprehensive regulatory power has enabled it to set up a planning process that can, in principle, incorporate all issues while balancing protagonists' interests. Furthermore, there is possibly enough equality between individual Wisconsin utilities so that competition can discipline their submissions to the PSCW.

However, the PSCW's regulatory power should be strongly contrasted with, for example, the regulatory jurisdiction in California, where only IOU participation in transmission projects is regulated. Direct application of many aspects of the Advance Plan process in states other than Wisconsin would therefore require changes to laws. The structure of the Vermont Electric Transmission Company (VELCO) or voluntary associations such as the Large Public Power Council (LPPC) or the Western Association for Transmission Systems Coordination (WATSCO) may be a viable alternative for embodying the Advance Plan principles, while also avoiding the need for legislative changes.

The information issue is more problematic. In the case of Wisconsin, the Wisconsin utilities have pooled their collective knowledge of system loadflow and generation data pertaining to Wisconsin and most of the rest of the Midwest in order to facilitate transmission studies. While each Wisconsin utility might individually want to restrict access to information about its system, the discipline of multiple protagonists of approximately equal size and expertise helps to reveal the information.

The Wisconsin Advance Plan model may therefore be more applicable at a inter-regional planning level, where each region could pool enough resources collectively to perform adequate technical studies of inter-regional transmission. We argue that competing regional interests would possess enough resources to perform inter-regional analyses that would discipline submissions to a planning body. The main concern of an inter-regional planning body would be to provide adequate inter-regional transmission capacity, while avoiding major over-spending on capital projects. A voluntary inter-regional company or association along the lines of VELCO or WATSCO, could provide a forum for this planning without significant legislative changes and without ongoing litigation over transmission access.

At the intra-regional level, we agree with the FERC Transmission Task Force Report in suggesting that slight over-building of transmission may be a small price to pay for competition in generation. This would mesh well with an intra-utility resource acquisition framework such as PG&E's multi-attribute bidding framework (see Section 5.2.4), which, we argue, functions best in the presence of some excess transmission capacity. Furthermore, issues such as

transmission access for independent power, which are not prominent in the Advance Plan Process, could be resolved through a framework such as PG&E's.

Summarizing these observations, the role of transmission associations and companies and of regulation would be restricted to two areas:

1. prevent major over-building at the inter-regional scale, and,
2. encourage minor over-building at the intra-regional scale, both between utilities and within a given utility's transmission network to accommodate transmission transactions.

We propose that large transmission projects would be evaluated by a regional association in the same way as the Wisconsin Interface Study. Problems such as externalities would fall naturally within the compass of a regional planning body. Inter-regional planning could be pursued to a great extent under existing state regulation; however, to solve issues such as asymmetric regulatory constraints, legislative changes would be required in some states.

Several issues remain that seem problematic, including optimal network expansion planning considering economies of scale and uncertainties in growth. The large-scale transmission planning software models we review approximate network expansion by assuming that lines are radial and by ignoring economies of scale. The reason for these approximations is ultimately the complexity of optimal network expansion, both computationally and because of the information burden it imposes, particularly as regards future demand and generation scenarios. While there is considerable theoretical work on optimal network expansion, there does not seem to be any commercial software with this capability. The industry could benefit significantly from practical software that performed true network expansion planning that considered economies of scale. Building blocks for this software would be better techniques for characterizing transmission system capability.

Uncertainties in future load growth provide special challenges because of the risk associated with taking advantage of economies of scale. One way to ameliorate the risk due to future uncertainties in network expansion is to delay commitments to new incremental transmission by temporarily increasing transmission capacity through technology such as 'Flexible AC Transmission' (FACTS). FACTS technology can be used to increase the transfer ratings of existing lines. Its advantages include:

1. it can be relocated in a system as requirements change, and,
2. it can be added in relatively small increments without sacrificing economies of scale.

If need for increased transmission capacity is then established in the long-run, transmission line construction can be undertaken and the FACTS equipment moved to another line. Using FACTS to temporarily increase transfer capacities can reduce the risks of uncertain futures by delaying commitment to large capital-intensive projects.

In conclusion, we observe that significant progress is possible in regulatory treatment of transmission through use of proposals and ideas that are currently being tested. Better software models would benefit the industry significantly.



# **Chapter 1**

## **Introduction**

### **1.1 Purpose of this Study**

Electric power must be moved from generators to load centers over transmission and distribution networks. These networks are large, complex, and valuable. They are owned and used by potentially competing participants. Issues concerning the transmission system are increasingly important, as utilities and their regulators evaluate options for:

- expanding the capacity of utility systems, and,
- increasing competition in the generation sector.

There has been growing interest in this subject, accompanied by a substantial policy debate. The focus of this debate has been primarily at the national level. Yet state action is critical to the expansion of the high-voltage transmission network, because regulated utilities must seek approval from utility commissions for proposals to site new lines. This siting process brings all the policy issues debated in general terms down to case and circumstance specifics.

It is the purpose of this report to survey the regulatory treatment of issues that are unique to or ubiquitous in transmission planning and use. We review recent transmission siting cases to examine how the issues are presented to and resolved by state regulatory commissions. Our primary focus is on planning issues and to provide a perspective for more general discussion of transmission policy. Regulatory approval requires that satisfactory answers be given to the basic question, 'Why should a particular project be built?' This is typically the framework adopted when utilities propose new bulk power capacity additions.

Transmission capacity expansion is not typically treated in integrated resource planning. It is usually assumed that there is adequate transmission to achieve any particular plan. We believe that one important reason for this omission is the inherent complexity of transmission system expansion. Analysis of transmission issues is among the most technically difficult aspects of electric utility planning and operations, relying on detailed technical data. This complexity is exacerbated by conflicts that arise from the increasing competition in the generation sector. This competition leads to conflicts over the use of the transmission system. Unfortunately, handling difficult and detailed technical information in settings of conflict can easily lead to opportunism. Regulators and competitors may be at a serious disadvantage in negotiating or adjudicating specific transmission proposals with utilities, who generally have greater knowledge of both general technological considerations and case specifics. This problem of asymmetric information must be addressed at some level in planning or dispute resolution. However, we will observe that explicit consideration of the information problem is absent from most regulatory and technical analysis of transmission.

The goal of this survey is to share knowledge about the problems facing state regulators over the siting of new transmission facilities, and help to define constructive approaches to them.

## **1.2 Organization of Report**

Our study is organized as follows. In Chapter 2, we define a typology of issues that will be used to organize our survey of cases. The typology considers three general categories of issues: institutional, technological, and decision-making. This section serves as an overview of the conflicts that arise more specifically in our case studies, an introduction to basic features of transmission technology, and a constant reminder of how the technical complexity of bulk power transmission influences decision-making. A common thread in the cases surveyed is the conflicts among objectives that must be resolved in regulatory decision-making or through other mechanisms such as markets. These conflicts, described in following chapters, often combine fundamental issues of regulatory policy with technical questions. The resolution of these transmission planning cases requires understanding of both the technological and the institutional issues. Unfortunately, much analysis in the literature is limited in its treatment of the technological details or of the institutional constraints. Furthermore, piecemeal analysis of institutional and technological considerations allows the technological issues to be manipulated in pursuit of institutional goals. We try to draw these issues together into a coherent picture.

The case studies are divided into three groups in Chapters 3, 4, and 5, respectively. In Chapter 3, we examine the treatment of transmission in four Utility Integrated Resource Plans (IRPs). Integrated resource planning has traditionally focused on just supply and demand. However, the transmission system is the link between generation sources and end-use customers, and the emergence of significant transmission constraints in recent years has prompted several utilities and State Commissions to consider transmission more explicitly in integrated resource planning. The utility IRPs considered are: (1) Florida Power Corporation, (2) Nevada Power Company, (3) Niagara Mohawk Power Corporation (NIMO), and (4) Pacific Gas and Electric's (PG&E's) Delta Project.

In Chapter 4, we examine five transmission construction projects under the jurisdiction of state regulatory commissions. All of these projects involve interactions that are external to a single utility. The inter-connecting parties in these cases may be competitors or co-operators; but whatever their status, they must share in the costs and the benefits. Typically, it is the estimation of benefits which is difficult. In the presence of competition, allocation of costs can become contentious. The projects we examine are: (1) Second Devers-Palo Verde Line (DPV2), (2) California-Oregon Transmission Project (COTP), (3) Kramer-Victor Line (K-V), (4) Duquesne Light/GPU Joint Venture (DL/GPU), and (5) Consumers Power-Public Service of Indiana Line (CP-PSI).

Each study highlights several of the institutional, technological, or decision-making issues raised in Chapter 2. Collectively, the studies indicate that one or more of these issues has been left unresolved in practice in each major transmission project.

Many organizations, both private and public, have proposed or are actively using frameworks to resolve transmission issues. These initiatives treat both the issues involved with new construction, as exemplified in the case studies in Chapters 3 and 4, and also access to existing transmission for third parties. In Chapter 5 we select the following utility proposals and frameworks for review: (1) the Vermont Electric Transmission Company, (2) the Western Systems Power Pool, (3) the Large Public Power Council Proposal, and (4) Pacific Gas & Electric's Multi-Attribute Bidding Framework.

We then review the Public Service Commission of Wisconsin 'Advance Plan' process and the California Public Utilities Commission Rules on Access to Computer Models.

At the Federal level, the Nuclear Regulatory Commission, the Federal Energy Regulatory Commission, and Federal Court have adjudicated several watershed cases that set precedent, or at least suggest future trends in Federal legislation or policy. In Chapter 5, we consider the following Federally adjudicated cases: (1) Pacific Gas and Electric's Stanislaus Commitments, (2) Toledo Edison and Cleveland Electric Nuclear Plant License Conditions, and (3) Utah Power and Light-PacifiCorp Merger Conditions.

We examine each proposal, framework, legislation, or case from the perspective of the issues described in Chapter 2. We ask: 'if the key points of this initiative were used to assess the transmission projects described in Chapters 3 and 4, then would the issues raised in Chapter 2 be resolved coherently?' Unfortunately, many perform relatively poorly on various issues; however, we believe that combinations, particularly combinations of complementary State and regional initiatives, may be able to resolve almost all of the issues simultaneously.

Chapter 6 focuses on the role of complex economic-engineering analysis in transmission planning. We summarize state-of-the-art transmission planning as described in Stoll (1989) to serve as a bench-mark for comparison, briefly indicate the scope of the studies that are actually performed in practice to analyze wheeling transactions by a sampling of Californian utilities, and then survey the software available for use in administrative adjudication. The software packages are: (1) Decision Focus' model of California transmission, (2) Pacific Gas and Electric's LOCATION, (3) Meta Systems' WRATES, and (4) Sierra Energy and Risk Assessment's SERAM.

To complement our description of planning models in Chapter 6, we include in the Appendix a discussion of the characteristics of the electric system that necessitate these sophisticated and comprehensive models and survey some of the relevant economics literature on the economics of information revelation and transmission system regulation.

In Chapter 7, we offer conclusions and suggestions for additional research.



## Chapter 2

# A Typology of Regulatory Issues in Transmission

### 2.1 Overview

In this chapter we present a typology of transmission planning and capacity issues. Our list (which is summarized in Table 2-1), consists of issues that have been explicitly considered by regulatory agencies in our case studies and also of issues that may warrant consideration but which have not appeared prominently in the regulatory discussion to date. We illustrate the issues with simplified examples that allow each issue to be discussed separately. Our discussion augments and complements the issues described in the Federal Energy Regulatory Commission's (FERC's) Transmission Task Force Report (FERC 1989); in the National Regulatory Research Institute Report (NRRI) on Wheeling (NRRI 1987); and, in the United States Office of Technology Assessment (USOTA) Report on Wheeling (USOTA 1989).<sup>1</sup>

We divide the issues into three major categories: institutional; technology structure; and, decision-making complexity. We first address the category of institutional issues, beginning with competition between transmission-owning and transmission-dependent utilities over access to transmission. We will generically refer to this as wheeling access. The competition issues associated with unregulated private producers, which are qualitatively different from inter-utility competition, are treated separately.

Three pervasive institutional problems in regulation that we confront are:

1. asymmetric regulatory constraints on different types of entities in the utility industry;
2. the adoption of differing objectives by different branches of regulation. This problem is magnified by the occasional difficulty in discerning the objectives of regulatory agencies; and,
3. the distinction between pecuniary benefits, which arise from side payments between participants, and real benefits, such as, for example, gains of trade.

These issues are complicated by the information asymmetries between regulators and utilities and also information asymmetries amongst utilities. Independent analysis and verification of utility positions is severely constrained by the limited availability of verifiable proprietary information concerning, for example, transfer capacity limits and also, by the lack of independent technological capability to review studies critically.

The final institutional issue we discuss is the adoption of standards. Standards reduce the cost of participation in a system by unifying procedures. For example, uniform standards for

---

<sup>1</sup> The last two references give excellent descriptions of operational issues in electric transmission.

assessing transmission capability would aid in the verification of utility proposals for the necessity of transmission expansion.

The second major category of issues we discuss is due to technology structure. We describe the distinctions between radial and network transmission expansion and note that transmission often involves externalities; that is, situations in which the actions of one party have effects on others. Most transmission-related externalities are negative; that is, costs are imposed on third parties; however, in some cases, the externalities are positive. Identifying and assessing the impact of externalities must precede some method to compensate for their effects, or to allocate their costs. Because of jurisdictional boundary issues, the presence of externalities on a regional scale brings into question the ability of state regulation to pose and answer relevant questions in cost/benefit analysis. A related issue is the synergistic effects of combinations of projects.

Two further technological issues that are distinct from externalities are:

1. economies of scale, and,
2. economies of scope.

Both issues stem from the inherently multi-purpose nature of transmission, which serves both multiple generators and loads. These characteristics are intrinsic to transmission projects and present major equity problems in allocating the cost of projects to participants. We assess these issues and also address risk in speculative building of transmission that takes advantage of economies of scale. Some readers may wish to begin with the technology structure discussion (Section 2.3) before addressing institutional questions (Section 2.2).

The third category of issues stems from the complexity of decision-making in transmission operations and planning, which makes it difficult to operate the transmission system optimally or plan transmission expansion optimally. Instead, the goal of transmission operations and planning is often feasibility with respect to a set of criteria, including financial viability, rather than optimality. We discuss the feasibility versus optimality issue both in the short-term from an operational point of view and also in the long-term for transmission construction. Then the balance between these short-term and long-term goals is discussed.

Table 2-1 summarizes these issues. In the following subsections, we define them in detail.

**Table 2-1  
Summary of Issues that Arise in Transmission Planning**

Category	Issue	Features
Institutional	Competition	Wheeling Access for TDUs
		Independent Power
	Regulation	Asymmetric Constraints
		State and Regional Conflicts
		Pecuniary versus Real Benefits
	Information Asymmetries	
Standards		
Technology	Line Characteristics	Radial
		Network
	Network Externalities	Negative
		Positive
Structure	Economies of Scale	Synergies
		Intertemporal Allocation
		Growth Uncertainties
Unsustainability		
Economies of Scope		
Decision-Making Complexity	Feasibility versus Optimality	Operations
		Planning
		Operations and Planning

## **2.2 Institutional Issues**

### **2.2.1 Competition**

We describe two forms of competition in the utility industry: between utilities over access to transmission services such as wheeling, and between utilities and independent power producers.

#### ***Wheeling Access for Transmission Dependent Utilities***

Ownership, control, and access to transmission largely defines the competitive balance between the transmission-owning and the transmission-dependent utilities (TDUs). Broadly speaking, TDUs owned by local governments have historically been at a competitive disadvantage in securing contracts for supply relative to the investor-owned sector, which has typically owned the transmission system. Publicly-owned municipal utilities (MUNIs) have traditionally had to depend on wholesale purchases from larger local investor-owned utilities (IOUs). These wholesale transactions are currently regulated by the FERC.

There are exceptions, where publicly-owned utilities in large municipalities, such as the City of Los Angeles have achieved scale economies in generation and have constructed their own transmission facilities to reach low cost resources. Furthermore, in recent years, the economic balance has begun to shift as a number of aggregation mechanisms have been created that increase the ability of small municipalities to sponsor their own joint projects or participate in large IOU projects. These mechanisms include:

1. joint-action power agencies, and
2. rural electrification administration generation and transmission co-operatives.

In the 1970s, a number of individual municipalities and joint action agencies sought participation in large nuclear power plant projects sponsored by IOUs. Statutory authority over anti-trust issues was granted to the Atomic Energy Commission (AEC) and its successor, the Nuclear Regulatory Commission (NRC). Transmission service was made a licensing condition for a nuclear generation plant in a settlement known as the Stanislaus agreement (NRC 1981). Under the Stanislaus agreement, which will be reviewed in detail in Section 5.4, Pacific Gas and Electric Company (PG&E) agreed to provide transmission service to the Northern California Power Agency (NCPA), a group of small geographically dispersed municipalities. We also discuss a related case, the Central Area Power Coordinating Pool (CAPCO) agreements, which has had more far-reaching practical impacts.

Although the Stanislaus agreement has turned out to be an unwieldy guarantee of transmission service, the case represents an important landmark in an increasing series of demands from municipal utilities for transmission services, allowing them to develop their own resources and reduce their dependence on IOU wholesale supply. In the case studies reviewed in Chapter 4, we discuss two situations in which publicly owned utilities actually took the initiative, or



participated actively, in the transmission planning process in (somewhat uneasy) cooperation with IOUs.

Where cooperation is not forthcoming from the IOUs, and the MUNIs embark on projects of their own, duplication and overbuilding of transmission capacity may be inevitable. In this case, overbuilding is essentially a cost of competition in the generation sector. In evaluating the benefits of competition, the costs of over-built capacity necessary to enforce competitive markets should also be explicitly considered.

Total transmission capital costs represent between 10% and 20% of total electric utility investment (FERC 1989). The total potential benefits of increased competition in the generation sector and of better coordinated use of the transmission system may be roughly the same order of magnitude or smaller. However, the incremental costs of building enough transmission to achieve these benefits may be smaller still. An explicit consideration of the transmission costs to foster increased competition is suggested by the FERC Transmission Task Force Report (FERC 1989) and is an appropriate perspective in the case of MUNI participation in the California-Oregon Transmission Project (COTP), for example. (See Section 4.3.)

On the other hand, Averch-Johnson analysis (Averch and Johnson 1962) suggests that IOUs operating under cost-of-service regulation are motivated to over-invest in capital projects to increase their profits. If a utility can over-build while simultaneously withholding access to transmission, then the costs of overbuilding are incurred without the benefits of increased competition. We will see that the attempted IOU participation in the COTP may be of this character.

### *Independent Private Power*

Transmission planning also affects the competitive balance between IOUs and private power producers, including both Qualifying Facilities (QF) under PURPA and other Independent Power Producers (IPPs). In the absence of wheeling, the private power industry is a monopsonistic market: there is one buyer, the local utility, for the output of private producers in the utility's service area. Even if a QF or IPP intends to sell most of its generation to its local utility, it may seek wheeling service to mitigate the utility's monopsony power (FERC 1989).

Competitive issues arise in three separate ways. First, there is a long-run conflict over market share between IOU investment in new generation capacity and private power supply. Second, there is a bypass issue. Private producers can serve retail loads traditionally served by the utility if they can obtain transmission service.<sup>2</sup> This issue arises particularly in markets such as Texas where the private power industry is well established (PUCT 1990). Third, private producers could transcend the monopsonistic power of the local utility if they could wheel power to other

---

<sup>2</sup> In some cases, permission from the state commission may be necessary for this service.

utilities over the local utility's transmission system. Transmission access issues of this kind have arisen increasingly in competitive bidding (Kahn et al. 1990).

Monopsony power can be exercised by IOUs in transmission markets when private producers are located in geographically remote areas. In these cases, interconnection costs, normally the responsibility of the private producer, may include network capacity expansion investments that have system-wide benefits. Joint cost allocation problems of this kind can be used strategically by IOUs to the detriment of private producers. The Kramer-Victor case raises issues of this kind. (See Section 4.4.)

## **2.2.2 Regulation**

### ***Asymmetric Constraints***

Different utilities are subject to varying degrees of both State and Federal regulation. For example, in some states, MUNIs can propose and build transmission projects with minimal regulatory oversight, while IOUs must get approval from their Public Utility Commission (PUC) to build. We will see that COTP is a prime example of a proposal involving several participants who had to respond to different regulatory constraints.

### ***State and Regional Conflicts***

State PUCs and FERC have differing objectives in assessing transmission, "creat[ing] a tension that has grown with the development of interstate markets in electricity" (FERC 1989). For example, PUC evaluation of transmission projects in California is usually "independent of a broader state or regional perspective" (CEC 1991). In contrast, the FERC usually has a more regional perspective. Reconciliation of State and Federal objectives has been identified as a key element for the formulation of wheeling policy (Kelly et al. 1987, USDOE 1991/1992, and Stalon 1991b).

### ***Pecuniary versus Real Benefits***

Project benefits are sometimes obtained simply at the expense of other parties rather than being due to net social economies. The distinction has been central to Federal regulatory policy. For example, in the Initial Decision in the Utah Power & Light Company-PacifiCorp merger, the FERC used the term 'pecuniary' benefits to describe transfers that do not represent real efficiency improvements (FERC 1988a). The FERC's Transmission Task Force Report (FERC

1989)<sup>3</sup> also emphasizes the maximization of 'social benefits' (Varian 1984). To contrast with pecuniary benefits, we will call net social economies 'real' benefits.

The FERC's approach is in contrast with that of many state PUCs, which, in considering an application by an electric utility for a Certificate of Public Convenience and Necessity (CPCN), tend to view the costs and benefits accruing to native ratepayers of the applicant utility as paramount. This perspective leads "to parochialism in the system wherein managerial efforts to maximize benefits for native end-users leads utilities, often supported by their PUC, to use their control over transmission assets to capture monopoly gains for native end-users" (Stalon 1990b).

PUCs tend to disregard the costs and benefits accruing to other utilities and their ratepayers, particularly utilities and ratepayers in other states, so that 'pecuniary' and 'true' benefits are inter-mingled. An example of this inter-mingling is the evaluation of benefits due to changed QF payments. If the 'avoided cost' of generation is reduced, for example, through greater transmission access to cheaper resources, then QF payments are correspondingly reduced. To the extent that this induces an efficiency improvement by replacing QF generation having high (marginal) production costs with another resource having lower (marginal) production costs, then this is a real benefit. However, QF production levels may not change significantly, for example, because of 'must-take' contract provisions, so that the QF production costs remain the same. In this case, only the payments change, producing a pecuniary benefit for the utility having no 'true, societal' benefits. These issues are discussed by Jurewitz (1990).

### 2.2.3 Information Asymmetries

Each of the protagonists in the utility industry has differing private information, and each one will tend to present only the information that is favorable to its own position or to: "misrepresent its costs in an attempt to obtain higher prices and profits. This misrepresentation is not to be thought of as constituting fraud or as involving unsupportable [sic] claims but instead may involve the strategic choice of cost estimation methodologies and data sets to produce estimates in the favorable portion of the possible range" (Baron and Besanko 1984b).

Because of the technological complexities of transmission and the dependence of costs and benefits on case particulars, the information issue is central to the ability of the participants to come to reasonable agreement. One example of a contentious issue is the characterization of the amount of 'excess' capacity in a system (Kelly et al. 1987). It is difficult for interested parties to verify the use and available capacity of the existing transmission system and the cost basis and data of system improvements (CEC 1991). Alahydoian and Cornnes note in a recent report on QF transmission needs that: "[i]nformation on the actual capacities of transmission

---

<sup>3</sup> See, for example, the discussion of wheeling in (FERC 1989).

lines and the effects of new power on the lines is closely held by the owning utilities; little data is available to QFs" (Alahydoian and Comnes 1990).

The strategic use of private information becomes evident when there are inconsistencies between the positions of a participant in one proceeding compared to its position in another. For example, concerning Southern California Edison's proposed Devers-Palo Verde 2 line (DPV2) examined in Section 4.2, an employee of a competing utility, San Diego Gas and Electric, stated that: "there was a lot of work to do with whether the studies that [Southern California] Edison was presenting in one arena in one study group had consistent basic inputs with studies they were presenting in another arena, and finding that where they were not consistent, insisting that they be made consistent so that the results were the same" (Mays 1990).

In the California Public Utilities Commission (CPUC) Decision in the California-Oregon Transmission Project, it is noted that: "[Southern California] Edison is simultaneously arguing [issues related to air quality] in opposite and contradictory ways in different proceedings" (CPUC 1991). In principle, these inconsistencies are public knowledge and therefore of a different character to true information asymmetries. However, we will describe them as information asymmetries because a huge effort is needed to verify the consistency of positions argued in different forums. We will see that the legislation in California concerning access to computer models is aimed at resolving this issue. (See Section 5.3.)

In the absence of *incentives* to reveal information truthfully, there are three generic ways the information issue may be approached: litigation, negotiation, and arbitration. Litigation can be very costly and not particularly efficient. Litigation of technical disputes is not without regulatory precedent. The CPUC devotes considerable resources to litigating avoided cost payments, where technical arguments often involve differences of less than a few percent. The CPUC regularly reports to the California legislature on its use of computer models for this purpose (CPUC 1987).

Even within the litigation paradigm, however, many parameters of the competing technical studies are 'stipulated' or specified by negotiation, because it is, practically speaking, impossible to litigate everything. In the case of DPV2, Southern California Edison (SCE) and the Division of Ratepayer Advocates (DRA) of the CPUC came to an agreement over a joint study to facilitate the analysis of DPV2 costs and benefits (CPUC 1988): the joint study increased cooperation between the protagonists in DPV2. (See Section 4.2.)

Arbitration is the polar opposite of litigation. The chief proponent of binding arbitration in transmission disputes is the Large Public Power Council (LPPC). The LPPC consists of major publicly-owned utilities, some of whom own transmission assets. While the LPPC approach to transmission planning emphasizes voluntary participation in most respects, the LPPC, as well as the Vermont Electric Transmission Company, the Western Association for Transmission Systems Coordination (WATSCO), and the Western Systems Power Pool advocate binding arbitration. (See Section 5.2.) While conceptually distinct from the litigation model, both the

arbitration and negotiation models are not without elements of strategy, differential information, and the use of market power.

#### **2.2.4 Standards**

The adoption of technical standards is a positive 'network' externality (David 1987); however, we note that this type of externality is different in character to the technological externalities to be discussed in Section 2.3. We will consider institutional aspects of standards and analyze standardization of:

- transmission planning, including:
  1. reliability criteria,
  2. computer models and data formats, and,
  3. the evaluation of benefits;
- transmission access policies and protocols; and,
- pricing methods.

There are currently no widely agreed upon standards for evaluating transmission benefits. Consequently, evaluation of transmission proposals tends to be *ad hoc* and case specific: "individual utilities determine benefits,...and in many cases they may choose the methods and assumptions for making this determination. Different utilities can evaluate the same proposed transmission project using different methods and assumptions to assess benefits and arrive at different conclusions" (CEC 1991). Clearly, the lack of standards exacerbates the problem of information asymmetries by allowing utilities considerable latitude in their choice of benefit assessment methods.

Compounding the lack of standards in the evaluation of benefits of transmission construction, there are no standards for access to and pricing of existing transmission. For example, access to wheeling is usually negotiated on a case-by-case basis (Alahydoian and Comnes 1990). Similarly, wheeling access conditioned by the NRC or FERC has been very case specific.

The lack of standards for transmission access and price make it very difficult for transmission dependent parties to negotiate with transmission owners. Even such pedestrian standardization as a uniform *pro forma* for transmission contracts would significantly reduce the transaction costs of transmission contracting. For example, one of the main successes of the Western Systems Power Pool is its uniform contractual umbrella for transmission services. (See Section 5.2.)

## 2.3 Technology Structure

### 2.3.1 Line Characteristics: Radial and Network

We distinguish transmission projects into two conceptual categories: radial and network connections. Radial connections involve the initial connection of two participants where there was no prior interconnection, or the strengthening of a corridor between two participants. The most obvious example is the radial connection of a non-utility generator to a utility's transmission system; however, the California-Oregon Transmission Project (COTP), which strengthens transmission links from the Pacific Northwest into California, is also included in this category.

Network connections involve the power *grid*. Capacity is usually added over an extended period in complex patterns between many individual pairs of nodes in the network. Sometimes a single line possesses both radial and network characteristics, particularly over the course of its lifetime if the overall network is growing significantly. Some cases exhibit both radial and network characteristics simultaneously: for example, the COTP raises both radial and network issues because of parallel flow in the Northwest network. Furthermore, a radial connection may require 'downstream' network reinforcement.

In general, new generation resources need not immediately necessitate reinforced 'network' transmission capacity. For example, California Energy Company, a private geothermal developer, argues that "the main long-run impact of QF-power on 'bulk' transmission will be to *release capacity*" (CECI 1990). This argument is based on the assumption that QF resources will be closer to load centers than alternative resources.

However, whether the effect of a resource is to increase or decrease the load on the transmission system, the addition of new generation will almost always affect the optimal long-term transmission plan. Therefore, transmission must generally be considered in the context of long-term planning. We examine the interaction of resource and transmission planning and its treatment by the utilities and the regulatory process. In particular, we consider how the potential expansion of independent power production is treated in utilities' long-term transmission plans.

Corresponding to our categories of transmission expansion, we define a 'remote' energy resource to be one that needs significant radial transmission construction to be able to supply any power to the network. In contrast, a 'local' resource can at least interconnect with the transmission system at low cost, although full exploitation of the resource may still require network transmission expansion. Generating resources can be roughly divided into remote and local; however, these definitions are meant as a guide and should not be taken literally since a single resource may possess both local and remote characteristics under differing perspectives. For example, a generation project may serve both local load as well as export power to a distant load center.

Benefits of transmission construction can be divided into benefits that stem from resources 'at the end of the line', and benefits from system-wide effects. The former category corresponds roughly to radial transmission projects, while the latter corresponds to network connections.

By definition, a remote generation resource requires new radial transmission capacity. In connecting a remote generation project to the transmission system, the radial connection costs are fairly easy to quantify. The joint investment costs for developing both the resource and the required transmission capacity must be weighed against the operating benefits and costs. The required transmission is essentially part of the generation development cost and can easily be internalized into the costing of the complete project. This case is not particularly problematic and we will not study it in detail, except where the choice of interconnection with the network, and hence the choice of radial connection, is contentious.

We will see that the large scale transmission planning software models that we survey essentially treat all transmission links as radial; that is, to increase transfer capacity between two points, the models only consider reinforcement of the actual link between the two points. This is at variance with practical transmission expansion, where overloads in one link are often alleviated through the change in power flows that result from increasing the capacity in another part of the network. The analysis of long-term *network* expansion is much more difficult than the analysis of *radial* expansion. In Example 1, we will illustrate the difference between radial and network expansion.

#### **Example 1: Radial Versus Network Expansion**

Consider the system shown in the top left panel of Figure 2-1. It consists of three nodes, G, L1, L2. There is 100 MW of generation at node G and 50 MW of load at each of nodes L1 and L2. A 100 MW line joins nodes G and L1, while a 50 MW line joins nodes L1 and L2. We ignore line losses and reactive power flows and assume that the cost of building additional transmission directly between any two of the nodes is approximately the same; this would be the case if the nodes are equidistant, as illustrated, and if the terrain and environmental considerations are the same for each of the three routes.

Suppose that the loads at nodes L1 and L2 will each increase by 50 MW and that generation at node G will increase by 100 MW. This would overload lines G—L1 and L1—L2 by 100 MW and 50 MW, respectively. A simple-minded transmission expansion algorithm that looks at line overloads only would suggest expansion of these lines as shown in the upper right panel of Figure 2-1. This transmission plan would require construction of a 100 MW and a 50 MW line.

A better plan, involving network expansion, is to build a new 100 MW line between nodes G and L2 as shown in the bottom panel of Figure 2-1. This transmission plan would only require construction of a single 100 MW line, saving the cost of the 50 MW line. Moreover, the overloads on lines G—L1 and L1—L2 are alleviated by construction along another path, G—L2.

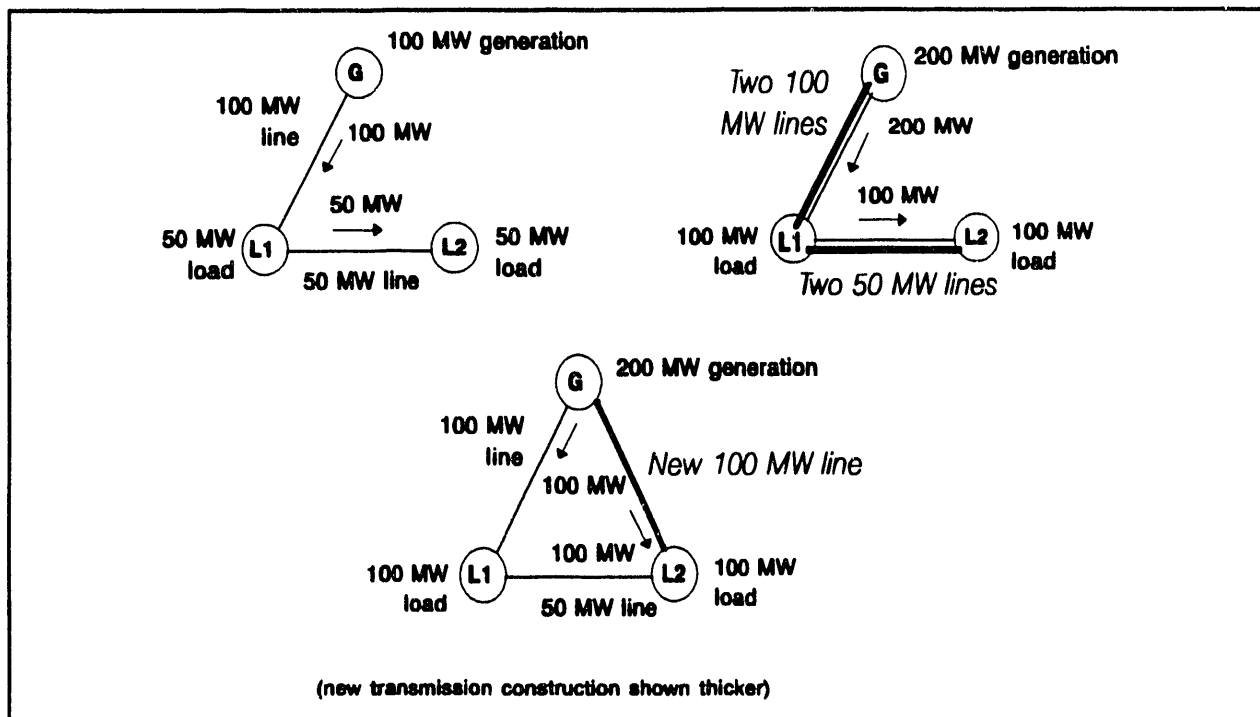

**Figure 2-1**  
**Lines, Generator and Loads for Example 1**

In this example, the benefits of network expansion over radial are obvious. In a real network, optimal planning is much less obvious. For example, in the Kramer-Victor case study, the initial interconnection proposal involved only radial expansion. Nearly a year later, a better network solution emerged. (See Section 4.4.)

We will discuss transmission planning in detail in Chapter 6, but note here that a generation project requiring network expansion may affect network construction projects and expansion plans well into the future. However, such transmission planning is fraught with uncertainties over costs and benefits. Assessment of network expansion is much more problematic than assessment of radial needs.

We examine a number of problematic cases in Chapter 4 that involve transmission investments that are either (1) not coupled to specific generation projects, or, (2) involve network expansion, perhaps in addition to radial interconnection.

A significant benefit of such lines can lie in increased access to several resources, rather than access to one specific generation plant. The generation resources may be shared regionally, so that allocation of the benefits of access is also difficult. In the Kramer-Victor line, we will see that a lack of forethought in the regulatory consideration of cost/benefit allocation for transmission has led to significant disagreements. (See Section 4.4.)



There are also less tangible benefits of new transmission capacity that are important, but difficult to quantify. These include:

- reduced line losses;
- providing for future load growth, particularly if the transmission line construction strategically opens up a new right-of-way (CEC 1991);
- increased system security and reliability; and,
- increased transfer capability for economy energy.

All of these factors may play a part in the sizing and location of a line (Kelly et al. 1987).

Some of these benefits are primarily radial, some are primarily network in nature, some may be in either category. Reduced line losses in the system can be due to both (1) lower resistive losses in a reinforced corridor, and, (2) altered flows in the whole system. In the first case, the benefits are due to the radial nature of the transmission, while in the second case, the benefits are network in nature. Evaluation of losses in the second case proved particularly problematic for the Kramer-Victor line. Future load growth may be accommodated by both radial and network transmission capacity. Security and reliability improvements are essentially network benefits. Finally, economy energy benefits are usually due to increased access to a distant source of cheap power, so that such benefits may be considered radial. The benefits of new capacity are summarized in Table 2-2.

**Table 2-2**  
**Benefits of New Radial and Network Capacity**

Benefits of new capacity	Radial	Network
Reduced line losses	X	X
Provision for future growth	X	X
Security, reliability		X
Capacity for economy energy	X	

### 2.3.2 Network Externalities

Externalities occur when the actions of one group of economic agents have impacts—‘spill-over’ effects—on parties who are not directly participating in the given activity. It is common to think of externalities as primarily negative, largely because of the much discussed example of environmental pollution. In network settings, however, there can be positive externalities. For example, telephone users benefit when the telephone network expands because they gain the possibility of communications for which they did not pay. In electric power transmission there are both positive and negative externalities. A related issue is the synergistic combination of multiple projects. Negative and positive externalities and synergies will be discussed in the following subsections.

#### *Negative Externalities*

The principal negative externality in transmission is unintended power flows; that is, where power flows in directions unrelated to the ‘contract path’ (Kelly et al. 1987). This phenomenon is called ‘parallel flow’ and is well-known in the Western and Northeastern United States (Hayward et al. 1991).<sup>4</sup> For example, one aspect of the DPV2 study is the resolution of parallel flow issues. With parallel flow, parties to an economic transaction impose impacts upon uninvolved third parties, who may be geographically remote. The impacts include changed line loadings and losses, and are usually not beneficial, so that we will typically treat them as negative externalities.

Contractual arrangements for transmission service are almost always described in terms of a ‘contract path’. Since the actual flow of electricity respects the load flow equations (Stevenson 1982) and not contractual arrangements, there are essentially always negative externalities involved in contract path-based transmission agreements, making economic efficiency very unlikely.

A very important network externality occurs when “[a] particular line within the system may be limited to carrying less power than that for which it is designed because of system-wide considerations” (Kelly et al. 1987). This is because, not only are losses imposed on third parties, but also because line *ratings* are effectively reduced. In other words, both the operating and the capital efficiency are reduced. We can illustrate this with the following simple example, consisting of a generator and a load connected by a relatively strong transmission path and also a weaker parallel transmission path.

---

<sup>4</sup> A related issue is ‘loop flow.’ Some authors treat parallel flow and loop flow as synonymous (Hayward et al. 1991), while others distinguish the two (Casazza 1991). We will, somewhat loosely, use the term parallel flow for all unintended flows.

### Example 2: Negative Network Externalities

The example is depicted in Figure 2-2. We consider the transfer capacity from the generator, G, to the load, L, along the two transmission paths illustrated. Suppose that the strong path, indicated by the thicker line in the figure, has capacity 1000 MW, while the weaker path has rating of 200 MW, with both ratings based on thermal limits. Assume that when the flow along the weaker path is 200 MW, the power flow divides in the ratio of 4:1 between the two lines because of their relative impedance. Assuming that the transmission lines are perfectly reliable, the strong line can only be loaded to 800 MW because of the limit on the weaker line.

Transmission planning tries to avoid this sort of situation. However, it may arise even in a well-planned system due to various line outage or generator loading conditions, particularly if an inter-connected system extends across more than one control area. The problem is prevalent in wheeling where large flows may occur in parallel systems.

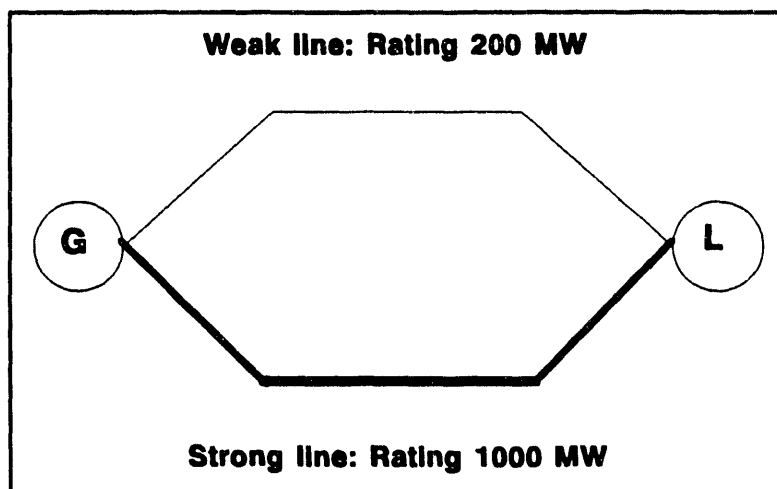

Figure 2-2  
Transmission Lines in Examples 2 and 3

Regulatory policy is difficult to formulate when the externalities are not local in nature: interstate externalities pose special problems for regulation. Such non-local impacts are frequent where unintended power flows are involved. Therefore, the issue may not even be raised at the state level, and appear only, if at all, at the federal level. In our case studies, we identify several examples and potential examples of network externalities over which regulatory authorities have no jurisdiction.

One approach the federal regulators have taken to unintended flows is the 'hardware solution' (O'Sullivan 1991). In this approach, the responsible utility is required to purchase equipment such as phase-shifters that will isolate the impacts of new lines or transactions from affecting other parties. Phase-shifters are illustrated in Example 3.

### **Example 3: Phase-Shifters**

Consider the network of Example 2. Suppose that a phase-shifter is installed on the weaker line and controlled so that power flow on the line is limited to no more than the rating of the line. For transfer levels up to 1000 MW, the phase-shifter will be controlled to have no effect on the system. For transfers above 1000 MW, the phase-shifter will control the flow so that 200 MW flows on the weaker line, and the balance of the flow is on the stronger line. The transfer capacity of the system is increased to approximately 1200 MW, based on thermal ratings, assuming that the phase-shifter can control the flow at this transfer level.

For transfers below 1000 MW, the phase-shifter can, in principle, be disconnected from the system so that no additional losses are incurred. For transfers above 1000 MW, the phase-shifter will incur losses in excess of the line losses in the system.

It may be more practical to control potential spill-over effects with phase-shifters, as in Example 3, than to attempt monetary compensation schemes for affected parties. However, if the costs of the control equipment and increased system losses are only allocated to the owners of new transmission projects, then this may unfairly discriminate in favor of existing lines.

A somewhat more localized form of externality is the environmental impact of transmission lines, including aesthetic and electromagnetic radiation issues. The aesthetic degradation caused by unsightly transmission lines has been of concern for many years. More subtle issues include degradation of delicate environments during construction work. Currently there is growing debate about the effects of electromagnetic radiation on living tissue (USOTA 1989). Although these issues are not, strictly speaking, 'network externalities,' we will include them here.

A positive externality is a situation in which benefits (instead of costs) are produced for parties uninvolved in a particular transaction. While this might appear to present fewer regulatory problems than the negative externality case, there are still cost and benefit allocation issues, particularly when the allocation is between current and future ratepayers.

An example of temporal allocation of benefits is the effect of new transmission lines in stimulating new load growth in the future by lowering the relative costs of inter-connection with the main transmission system (CEC 1991). This effect is difficult to quantify, but seems to be important in fast growing areas. Our analysis suggests that this was an important issue in the Kramer-Victor line.

The addition of a line in a network can enhance the reliability of the whole network, at a given transfer level, by increasing the robustness of the system to outages and disturbances. However, this observation must be viewed from the perspective that lines are rarely added to a system without also increasing the load carried by the system. The net change in reliability may therefore be positive or negative (CPUC 1988). In the following example, we consider the

positive externality of increasing the transmission capacity of the system of Example 2 by increasing the rating of the weaker line.

**Example 4: Positive Network Externalities**

Consider the network of Example 2. Suppose that the rating of the 'weak' line is upgraded by 100 MW by re-conductoring with heavier wire. Then we can also increase transfers over the 'strong' line. For example, suppose that when the new line is loaded to its upgraded rating of 300 MW, the flows divide in the ratio 3:1 between the two lines.<sup>5</sup> Then the total capacity of the network will be increased by around 200 MW with only a 100 MW increase in line rating of the 'weak' line.

Such a situation may apply in California transmission access to the Pacific Northwest. In this case, the 'strong line' corresponds to the corridor of lines through California and Oregon to Washington and British Columbia, while the 'weak line' is the network of inland lines from California through Arizona and Idaho to the Northwest. Strengthening the 'weak line' may have had a larger effect on transfer capacity than strengthening the 'strong line.' (See Section 4.3.)

***Synergies***

We define a synergy to be where the effects of two or more projects or factors interact non-linearly, so that the sum of their benefits considered separately is not equal to the project benefits of all projects considered together. Trivially, the benefit of either a radial line or a remote generator, considered individually, is zero. Jointly considered, a remote generator connected to a load center by a radial transmission line may provide considerable benefits. A more interesting example of synergies is illustrated in Example 5 concerning expansion of a transmission network subject to reliability criteria.

---

<sup>5</sup> The ratio is reduced because the upgraded line will have lower impedance than the original.

### Example 5: Synergies

Consider the network depicted in the top panel of Figure 2-3. The lines are identical and each is rated for continuous loading of 200 MW, with an emergency rating of 220 MW. Reliable service requires that the transmission network be loaded in such a way that any single outage will not cause loading of the remaining lines past their emergency ratings. This is called the 'N-1 criterion', and will be discussed in more detail in Chapter 6. Clearly, any single outage will leave only one line intact so that the reliable transfer capacity is the emergency rating of one line: 220 MW.

Consider now the effect of rebuilding either *one* of the lines so that it has a continuous rating of 1000 MW and emergency rating of 1100 MW. The situation is essentially as in Figure 2-2. The reliable rating of the network is still 220 MW since failure of the 1000 MW line would leave only the 200 MW line. However, if both lines are upgraded, as shown in the bottom panel of Figure 2-3, then the reliable transfer capacity is increased to 1100 MW. While each project individually did not increase the transfer capacity, together rebuilding both lines significantly increases the capacity.

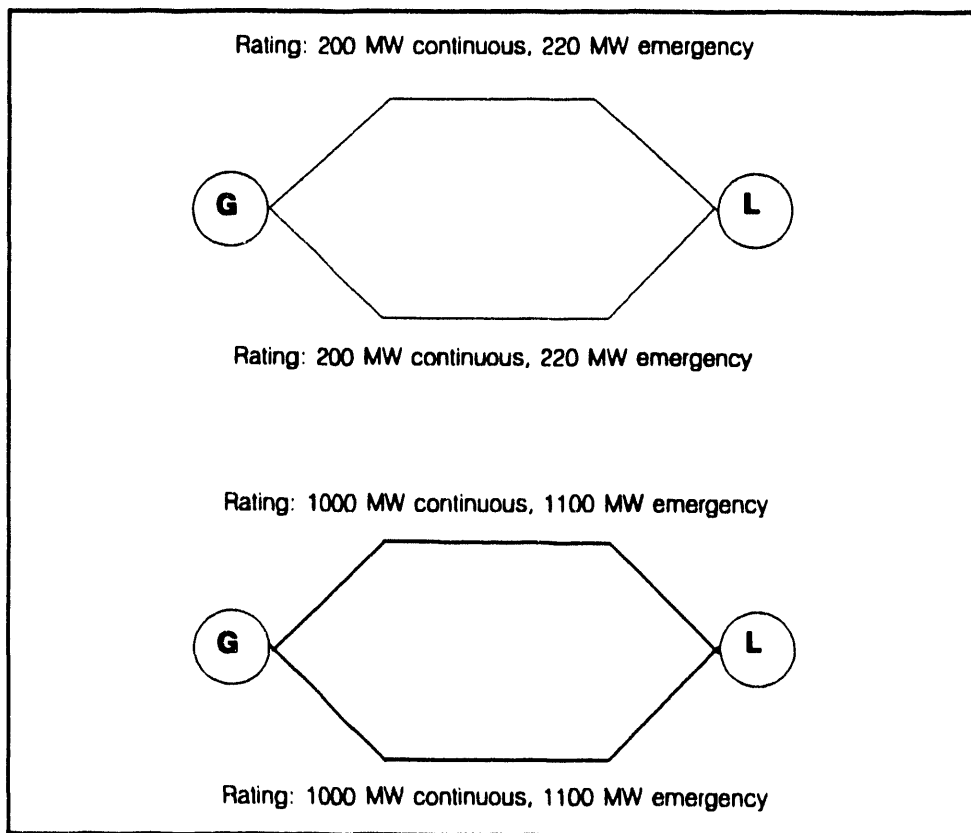

**Figure 2-3**  
**Transmission Lines in Example 5**

We broadly interpret 'synergies' to include both the case where the net benefits of the two projects is greater than the sum of their individual benefits, as in the last example, and also the case where it is *less* than their individual benefits. The second case is particularly troublesome, since piecemeal consideration of such projects will be misleadingly optimistic (CPUC 1988). Because the analysis of the isolated effects of transmission projects is difficult, it is even more difficult to analyze the effect of project synergies. The importance of such analysis is indicated by the results of the study commissioned by the California Energy Commission that examined the joint benefits of five California projects including COTP and DPV2 (DFI 1990). The study shows jointly optimal values of transmission expansion that in some cases differ greatly from the proposed capacities (CEC 1991), with typical jointly optimal capacities less than the proposed capacities.

### **2.3.3 Economies of Scale**

Transmission planning is strongly influenced by scale economies in construction, particularly if voltage is increased in order to increase capacity or if double-circuit lines are used instead of single-circuit. This raises joint cost allocation problems that are ubiquitous in transmission planning. If there is growing demand or supply, then economies of scale may dictate that it is most cost effective to over-build current levels of transmission to accommodate the future growth. For example, the need for a new line may be triggered in part by a specific generation project; but, since the incremental costs of additional transmission capacity are low, it may make economic sense to invest in additional capacity beyond the current need of the specific project. To illustrate this issue, consider the following example based on 1984 and 1985 construction costs reported by the Electric Power Research Institute (EPRI 1986) and Kelly et al. (1987). For simplicity, we assume that, within the range of uncertainty in the cost estimates, the 1984 costs are directly comparable to the 1985 costs. The data indicate that the average construction costs of new lines decreases significantly as voltage, and hence capacity, increases. In the following example, we will show that there are significant economies of scale, even including circuit-breaker, transformer, and other costs.

### Example 6: Economies of Scale of Line Construction

We first consider the costs of a 400 km, 275 MW, 230 kV single-circuit line that is to reinforce the interconnection between two 230 kV systems. Line construction costs, plus a 25% allowance for right-of-way and other costs, are approximately 39.5 M\$ (Kelly et al. 1987). The cost of circuit-breakers for both ends of the line is 0.8 M\$ (EPRI 1986) for a total cost of 40.3 M\$, or an average cost of approximately 147 \$/kW. A schematic of the line is shown in the upper left panel of Figure 2-4.

Next, we consider a 825 MW, 345 kV line. Because of the voltage differences, we must include the cost of transformers (TXs) and extra circuit-breakers (CBs). However, we do not consider any differences in the costs of capacitors nor other voltage or stability support required for the lines.<sup>6</sup>

Again, allowing 25% for right-of-way and other costs, the total costs are 79.9 M\$ (Kelly et al. 1987). The cost of circuit-breakers for protecting the transformers and both ends of the line is 2.5 M\$ (EPRI 1986), while the cost of two transformers is approximately 6 M\$ (EPRI 1986), for a total cost of 88.4 M\$, or an average cost of approximately 107 \$/kW. These figures are presented in Table 2-3 and a schematic of the line is shown in the upper right panel of Figure 2-4.

The average incremental cost between the 275 MW and 825 MW lines is 87 \$/kW. This is considerably below the average cost of construction. However, it may still be considerably more than the depreciated embedded cost of previous construction.

**Table 2-3  
Transmission Construction Costs for Example 6**

Voltage /kV	Capacity /MW	Line and Other Costs /M\$	Circuit Breaker Costs /M\$	Transformer Costs /M\$	Total Costs /M\$	Average Costs /\$/kW
230	275	39.5	0.8	0	40.3	147
345	825	79.9	2.5	6	88.4	107

In this example, the average capital cost of new transmission decreases with increasing capacity, even considering the transformation cost. Furthermore, this example tends to under-estimate the

<sup>6</sup> For detailed examples including consideration of stability and voltage support in evaluating the costs of alternatives, see, for example, (PG&E 1991a, SCE 1991, SDG&E 1991, and SPPC 1991).



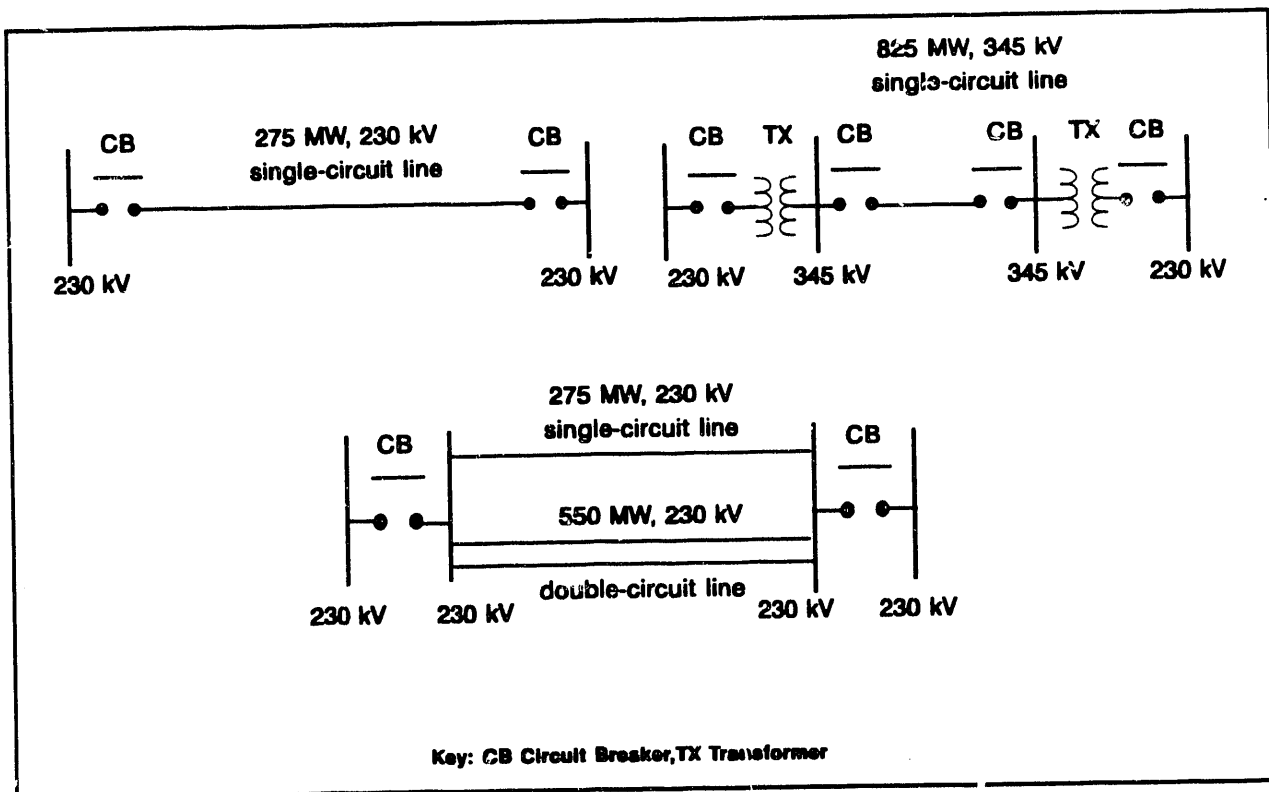

**Figure 2-4**  
**Lines and Transformers for Examples 6 and 7**

economies of scale, since, for a given transmission corridor, the right-of-way and other costs, excluding transformers and circuit-breakers, would not typically increase linearly with the transmission construction costs and may even be approximately constant. Finally, if the larger capacity line can directly interconnect with an existing higher voltage network, then the average transformation costs may not differ greatly between the two lines, further increasing the economies of scale. Pervasive economies of scale are intrinsic to transmission planning. In the following subsections, we discuss the complications that arise from transmission economies of scale, both with and without uncertainties concerning the future, and we also consider the effects of competitive supply for transmission service in the presence of economies of scale.

#### *Intertemporal Allocation of Benefits and Costs*

If the need for additional capacity due to demand and supply growth is predictable over time, then economies of scale can be exploited to build transmission now for the benefit of later users more cheaply than through piecemeal construction plans. The main problem is the intertemporal allocation of costs and benefits as illustrated in Example 7.

**Example 7: Intertemporal Allocation of Benefits of Economies of Scale**

Suppose that there is a current need for 275 MW of extra capacity along the 400 km transmission path in Example 5, but that in the medium term another 550 MW of capacity is required for a total of 825 MW of transmission capacity. The most straightforward 'myopic' plan is to build 275 MW of 230 kV line now and an additional 550 MW, 230 kV, double circuit line later, at the time the additional capacity is needed.

To calculate the cost of the myopic approach, suppose that the discount factor between now and the time of the necessary additional expansion is 15%. The initial 400 km, 275 MW, 230 kV line and circuit-breakers are built now at a cost of 40.3 M\$. The 550 MW double circuit line is built later. To calculate its cost, note that double circuit 230 kV lines cost about 1.43 times the cost of a single circuit line (EPRI 1986), while the construction costs in the future are discounted to constant (1985) dollars.<sup>7</sup> Therefore, the 550 MW double circuit line costs 49.2 M\$ in 1985 dollars, for a total cost of 89.5 M\$. Since construction costs are spent at the time of need, it is relatively simple to allocate construction costs for this plan to ratepayers. These figures are presented in Table 2-4 and a schematic of the lines is shown in the bottom panel of Figure 2-4.

An alternative plan is to build the higher voltage line, but operate the line at 230 kV until the higher capacity is necessary. At that time, the transformers and second pair of circuit-breakers are installed. The total cost of this option is 87.4 M\$, which is about 2% cheaper than the myopic plan.

**Table 2-4**  
**Economics of Over-Building Lines for Example 7**

---

	Current	Future	Total
myopic	40.3	49.2	89.5
non-myopic	80.7	6.7	87.4

---

In this example, the non-myopic plan yields benefits over the myopic plan; however, there are questions of how to allocate (1) the costs of construction of the overbuilt line, which must be borne in advance of the increased demand, and (2), the benefits of the economies of scale.

---

<sup>7</sup> We assume, optimistically, that no additional circuit-breakers are required for the double circuit line.

### ***Growth Uncertainties***

In Example 7, there is clearly an opportunity to over-build transmission relative to current needs if there is some opportunity to attract extra transmission customers, either currently or in the future. For an interim period, there may be 'excess capacity' even at the time of the system peak and there may be some, uncertain, opportunities for sale of capacity, at least in the short-term. Allocation of the proceeds from these sales is a difficult question, as is the question of accounting for such uncertain sales in the cost-benefit analysis of such a project. These represent uncertain benefits of the non-myopic alternative.

Since the savings of the non-myopic plan over the myopic plan are relatively small, then if demand or supply growth is relatively uncertain, the benefits of the project are speculative. Speculative building can only be worthwhile if there are scale opportunities that potentially offset the risks of overbuilding; however, the benefits may depend on the availability of generation resources that are diverse or perhaps not even developed. Geographically, specific resources such as geothermal energy are one example where there may be good, but not certain, reasons to believe that economically attractive generation can be developed, but is contingent on transmission access to major markets.

Speculative construction involves risks that may not be rewarded under standard cost of service regulation. This lack of incentives for risks in a regulated monopoly may encourage myopic behavior unless other considerations, such as restricted transmission corridors, preclude the future construction of a second line. Therefore, speculative projects are less likely to be undertaken solely by a regulated utility. Nevertheless, economies of scale in transmission construction present opportunities that should not be unnecessarily wasted.

One approach to taking advantage of speculative investment is a joint venture between regulated and unregulated participants. However, when there is a coexistence of regulated and unregulated participants, there may be a serious conflict of interests in cost allocation, particularly given information asymmetries concerning the risks of attracting transmission customers. We will see in the Duquesne/GPU proposal, however, that it may be possible to minimize the conflict of interest through appropriate sharing of the economies of scale. (See Section 4.5.)

Another potential approach to the problem of growth uncertainties is the emerging technology of Flexible AC Transmission (FACTS). This is illustrated in the following example.

### **Example 8: Flexible AC Transmission**

Suppose that the transmission expansion in Example 7 (see page 26) will reinforce existing capacity along a transmission corridor consisting of the lines in Example 2, with current transfer capacity limited by parallel flow. By temporarily installing FACTS technology, including the phase-shifters described in Example 3, the transfer capacity can be upgraded without new line construction. The decision to build new capacity at 230 kV or 345 kV can then be delayed until it has become clearer whether or not continued growth will justify the larger line.

When the new construction is completed, the FACTS technology can be moved to another part of the network. The cost of the temporary increase in transfer capacity would then only consist of minor facilities costs to accommodate the phase-shifters, the rental value of the phase-shifters, and the losses due to phase-shifter operation.

### ***Competing Transmission Supply and Unsustainability***

A further problem due to economies of scale can arise if a potential entrant can *compete* with an incumbent to supply transmission capacity and if continued growth calls for construction at several times as part of an optimal transmission plan. We apply some recent theoretical analysis by Baumol et al. (1988).

To analyze this case, we define 'sustainable prices' (Baumol et al. 1988). In the case of transmission supply, sustainable prices are a sequence of prices over time for transmission access that are:

1. high enough to allow the incumbent transmission supplier to pay off the capital costs of the existing transmission, but,
2. not so high that an entrant could undercut the prices, supply a segment of the market, and make a profit.

Unfortunately, the analysis in Baumol et al. (1988) shows that because (1) as shown in Example 6, there are declining average costs in transmission construction as a function of capacity, and because, (2) transmission construction costs are sunk, an optimal construction plan will usually be 'unsustainable'. Unsustainability means that there will be no sustainable prices, so that prices that allow the incumbent to pay off capital will invite 'uneconomic entry'. Uneconomic entry means the overbuilding of transmission by the entrant, relative to the social optimum, in order for the entrant to capture enough economies of scale to be profitable: the entrant takes away some of the market of the incumbent by charging lower prices, leaving unused capacity so that there is unnecessary duplication of transmission facilities. This is illustrated in the following example.

**Example 9: Intertemporal Unsustainability**

Suppose that an optimal transmission plan calls for the reinforcement of an existing 230 kV network by the 230 kV single-circuit line described in Example 6 (see page 24), costing 40.3 M\$. Further suppose that this line essentially parallels existing capacity and that the existing transfer capacity is considerably larger than the optimal 275 MW of incremental capacity.

Now suppose that a competing transmission supplier decides to build the 345 kV line described in Example 6 and install the transformers and circuit-breakers, for a total cost of 88.4 M\$. Since the average cost of the higher voltage line is much lower, the competitor can offer lower transmission prices to the incumbent's transmission customers and capture some of the existing market as well as all of the incremental needs for transmission.

Because of the large economies of scale, it is not necessary for the entrant to completely fill the capacity of the line in order to break even. For example, suppose that the incumbent sells transmission capacity on the existing network at the incremental cost of optimal transmission additions: that is, at a price of 147 \$/kW. Suppose that the entrant offers transmission service for 140 \$/kW, approximately a 5% discount below the incumbent's price. Then the entrant needs to sell about 630 MW of transmission service in order to break even. This represents all of the incremental market of 275 MW, plus about 355 MW of the incumbent's market.<sup>8</sup> These figures are presented in Table 2-5. If the entrant *can* completely fill the line, then it can break even at a price as low as 107 \$/kW.

**Table 2-5  
Costs and Break-Even Sales of Capacity for Example 9**

Transmission Plan	Added Capacity /MW	Total Costs /M\$	Sales to Break-Even at Price of 147 \$/kW /MW	Sales to Break-Even at Price of 140 \$/kW /MW
Optimal	275	40.3	275	-
Over-built	825	88.4	600	630

<sup>8</sup> A similar analysis can be performed for the more usual case that the transmission service is rented out by the transmission suppliers, rather than sold.

The 'competitive' situation in the above example may seem to be good since it reduces the prices for the entrant's new customers. However, it leaves existing transmission lines under-utilized and reduces welfare, since the smaller, less costly line, by definition, could optimally satisfy the transmission requirements. By losing market share, the incumbent's average proceeds from transmission service will decrease unless it can raise its transmission prices.

A fundamental assumption in the unsustainability analysis is that the incumbent is perceived to have set a fixed pattern of prices that are not responsive to actions by the entrant: in particular it is assumed that the entrant does not expect retaliatory price cutting in response to entry. Because tariffs must generally be approved by PUCs or FERC, which are presumably not sympathetic to retaliatory pricing, this assumption is relatively plausible.

We will see that the unsustainability analysis may apply specifically to the California-Oregon Transmission Project case study. The analysis applies generically to transmission planning involving more than one potential transmission supplier. It poses a general problem for transmission market-based pricing because the absence of sustainable prices may require strong regulation in order to achieve good planning: "there may be a stronger need for a centralized pricing mechanism in transmission markets than in other sectors of the industry" (FERC 1989).

The problems of unsustainability are implicitly at the heart of the Wisconsin PUC's mandate to avoid duplicative transmission expansion (see Section 5.3): "If the existing system is physically capable of handling a particular transaction it is unnecessary, uneconomical, environmentally damaging and counter to established principles of regulation to add duplicative facilities to serve that transaction," (PSCW 1989).

However, since the problem of uneconomic entry will arise just at a time when *some* construction is socially desirable, it may be very difficult for a State regulatory agency to discern whether or not facilities are duplicative, or whether or not they are overbuilt compared to the social optimum.

### **2.3.4 Economies of Scope**

Economies of scope occur when a single facility is used for more than one function. The clearest example of this is the transmission of electricity, viewed as a time-differentiated product, at different times of the day over a single transmission network. Another example is interconnection support, where energy may be shipped between utilities in one direction or the other at different times or different seasons to take advantage of peak diversity, shared spinning reserve, or to provide emergency support. In this second example, there are joint operational benefits making the allocation of the cost of the line more difficult than in the case of unidirectional flow, particularly if "the costs are incurred by one company and the...benefits are shared by many" (Kelly et al. 1987). The joint benefits of a line are illustrated in the following example, relating to peak diversity, which is based on an example from the National Regulatory Research Institute (NRRI 1987).

#### **Example 10: Economies of Scope of Transmission Use**

Consider the system shown in Figure 2-5. There are two utilities, 1 and 2, each with a single generator and a load center. They are linked by a single transmission line. Suppose that the peak of utility 1 occurs at 3pm, while the peak of utility 2 occurs at 5pm. For simplicity, we assume that the generators G1 and G2, owned by utilities 1 and 2, respectively:

- have constant marginal costs, and,
- are perfectly reliable.

Suppose that the sum of the capacities of G1 and G2 is enough to supply the total demand of L1 plus L2, the loads of utilities 1 and 2, respectively, at any given time. However, also suppose that G1 cannot supply the peak demand of L1 alone, and G2 cannot supply the peak demand of L2 alone. In the absence of the line interconnecting system 1 and system 2, both would need additional peaking generators to meet their respective peak loads. However, the line allows both generators to supply both loads collectively, so that there is an economy of scope in joint production made possible by the line. The line is justified if it is less costly than peaking generators for both utilities.

We note that one reason cited for the Utah Power and Light-PacifiCorp merger was the economies of scope in joint operation due to Utah being a Summer-peaking and PacifiCorp being a Winter-peaking utility (FERC 1987). (See Section 5.4.)

Another aspect of economies of scope is that over time, as a transmission network grows, transmission lines may change their function. For example, a line that was initially used for transmitting power Northward may eventually have mostly Southward flow as generation and load centers shift. This is the case in some of the lines involved in the Kramer-Victor case study. (See Section 4.4.)

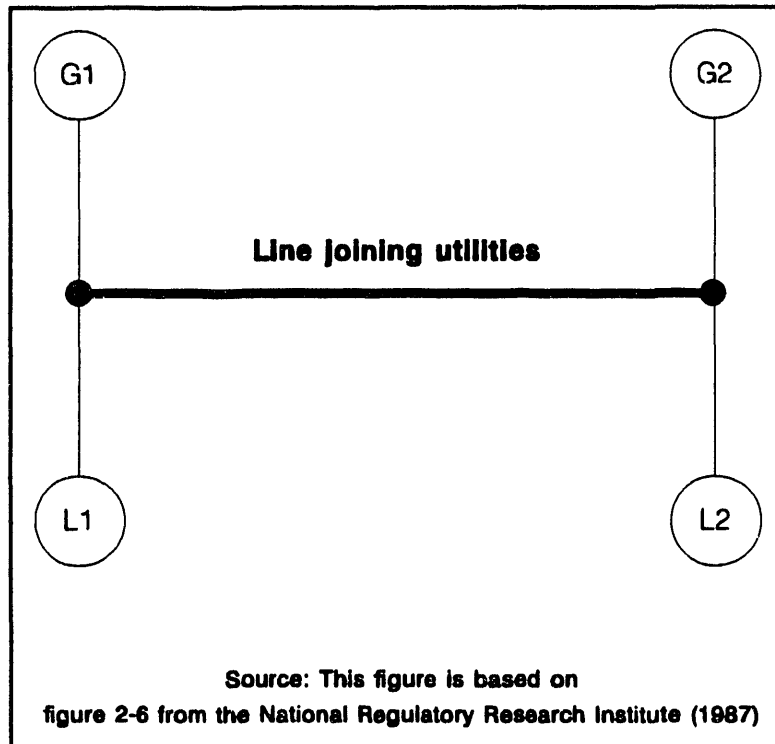

**Figure 2-5**  
**Generators, Loads and Lines for Example 10**

A particularly intriguing economy of scope can occur in wheeling transactions if the wheeling transaction moves power in the opposite direction to the existing power flow. We call this 'counterflow wheeling'. In this case, the wheeling transaction and existing flow together have *lower* losses and require a *lower* line rating than required by the existing power flow. We should expect that any tariff designed to promote economic efficiency would take account of the prevailing flow of power, at least for purposes of allocating the costs of losses. Therefore, a basic test for economic efficiency in transmission access is whether or not counterflow wheeling is treated properly. Typically it is not: for example, in the Utah Power and Light-PacifiCorp merger, counterflow wheeling is not considered.

## 2.4 Decision-Making Complexity: Feasibility versus Optimality

The many issues that we have raised in Sections 2.2 and 2.3 make it very difficult to either operate or plan the transmission network optimally, even given general agreement on the objectives and constraints imposed on the transmission system. The joint optimization of transmission, supply, and demand-side options in an integrated resource plan is a particularly daunting task and is just beginning to be attempted by utilities (NIMO 1991) and will be discussed in Chapter 3. While operations and planning must be feasible with respect to the institutional and technological constraints, they are often suboptimal with respect to the objective



of economic efficiency, for example. We will discuss these issues in the following two subsections. For clarity, however, we will suppress the complications of considering demand- and supply-side decisions together simultaneously with transmission. It should be noted that simultaneous consideration of all issues is necessary for truly integrated resource planning.

### **2.4.1 Operations**

The basic question in operational efficiency is whether the transmission system is utilized for the greatest economic benefit. The clearest example occurs in wheeling since wheeling affects access to resources. We illustrate this in the following example, which is paraphrased from an example by Gross (1991).

#### **Example 11: Operational Efficiency in Wheeling**

Consider the three utilities, S, W, and B, depicted in Figure 2-6. Suppose that the marginal generation cost for S is 18 \$/MWh, for W is 20 \$/MWh, and for B is 24 \$/MWh. For simplicity, we assume that transmission losses between S and W and between W and B are negligible, that S has surplus generating capacity, but that W does not have any surplus generating capacity.

With regional operating efficiency as the objective, it is clear that B should displace at least some of its production with purchases from S, using W to wheel. However, since W's costs are also higher than S's, W is also motivated to displace its production with purchases from S. Since B's marginal costs are higher than W's, efficiency is best improved by W wheeling at least some power. However, unless W is motivated to wheel by economic incentives, such as a high enough price for wheeling or is required to wheel by regulation, it will prefer to buy from S and block B's purchases.

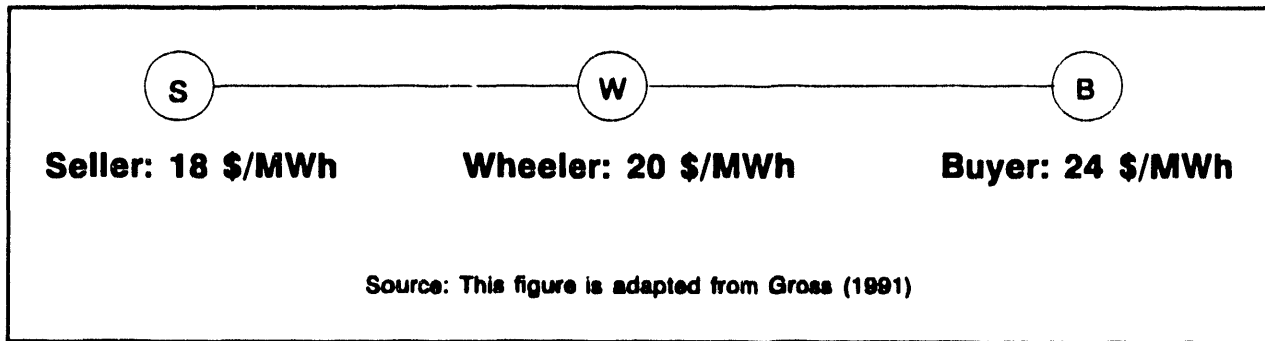

**Figure 2-6**  
**Utilities in Example 11**

The issue in this example is whether or not the wheeling utility is motivated to provide transmission service in an efficient way. We will assess the transmission access proposals in Chapter 5 from this perspective. Hobbs and Kelly discuss the incentives for wheeling (Hobbs and Kelly 1990).

A further complication is that when there are multiple potential transactions between a utility and its neighbors, the network externalities of transmission operation make it very difficult to calculate transmission limits. The evaluation of simultaneous transmission limits between a utility and its neighbors is beyond the capabilities of currently available software and is the subject of ongoing research (EPRI 1991).

#### **2.4.2 Planning**

Because of the huge informational and computation burden, and the uncertainties of future predictions in planning transmission expansion, it is generally difficult to optimize construction plans with respect to any given objective over an extended time horizon. We will discuss this in more detail in Chapter 6. More commonly, transmission is planned so as to satisfy constraints for a single future test year and a few study conditions. Even such limited analysis is time-consuming and dependent on many inputs based on 'engineering judgment'.

The potential difficulty in identifying optimal expansion plans was illustrated in Example 1. While that example was constructed so that the optimal solution is easy to see, in a larger system opportunities for savings and optimal solutions may be far from obvious, particularly if the optimal expansion plan would require construction of projects that cross jurisdictional boundaries. We will see that the COTP may fall into this category. Even in a case such as Example 1, however, the seemingly reasonable approach of applying remedial action individually to overloaded lines will produce sub-optimal results.

Although global optimality may be computationally infeasible, the effort to optimize transmission will reveal sensitivity of the objective to various factors. Sensitivity analysis is useful in informing a prudent policy that balances risk and benefits, even when the study results are viewed with some skepticism. To illustrate the importance of risk hedging in planning, consider Example 12.

**Example 12: Risk Hedging in Planning**

Consider the utility U, shown in Figure 2-7, which is building two transmission lines to two remote resources, R and S, which have been acquired by the utility. Utility U anticipates that load growth will necessitate additional generation construction in the future at one, but not both, of the locations. However, the choice of future construction depends on a number of uncertain factors.

The utility can take a myopic viewpoint and build only adequate transmission capacity to interconnect with R and S. Alternatively, it can prepare for future growth by overbuilding the transmission towers on one or both of the lines. It may be cheaper to overbuild the towers of *both* lines now than build a completely new line later, even though the utility is sure that it will need to expand only one line. Because of the uncertainty in future plans, the utility may incur extra costs by overbuilding; however, by hedging against both alternative growth possibilities, it can avoid the future cost of a completely new line.

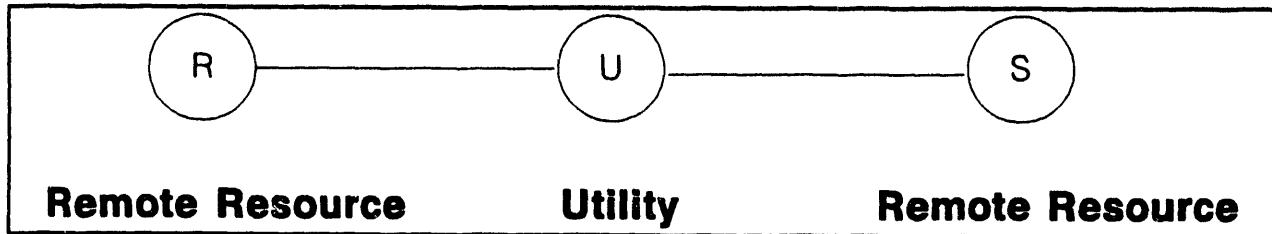

**Figure 2-7**  
**Utilities and Resources in Example 12**

We will see that overbuilding of towers in the Kramer-Victor case study can be interpreted as planning for future uncertain growth.

### 2.4.3 The Balance Between Operations and Planning

While we have discussed operations and planning separately, it is important to recognize that each affects the other. While operations can be optimal with respect to a given level of transmission, and planning can be optimal with respect to given operational practices, consideration of one to the exclusion of the other can lead to significant inefficiencies. In Example 11, it may be possible for a regulatory authority to order W to wheel for B and S. For example,

W may be required to make any excess capacity in the transmission system available for wheeling at embedded costs. Disregarding the information asymmetries between W; the regulator; and, B and S, over W's excess capacity, it may be possible to achieve short-term efficiency.

In the long-term, however, W may decide not to expand its transmission capacity adequately between B and S if it must make any such capacity available for wheeling and cannot itself profit from the transmission. In the long term, the lack of adequate transmission capacity could have much more significant effects than the short-term gains of trade from the wheeling. To be effective, a short-term access policy must be complemented with long-term provisions for construction. The short- and long-term provisions of the Utah Power and Light-PacifiCorp merger commitments illustrate this interplay of operation and construction. In Section A.3 of the appendix, we discuss some of the economic literature on wheeling that considers the interplay of short- and long-term issues.

## Chapter 3

# Utility Integrated Resource Plans: What Role for Transmission?

### 3.1 Overview

In this chapter, we examine the treatment of transmission planning in Integrated Resource Planning (IRP) through a review of the IRP plans of four utilities:

1. Florida Power Corporation;
2. Nevada Power Company;
3. Niagara Mohawk Power Corporation; and,
4. Pacific Gas and Electric's Delta Project.

The first three plans are conventional IRPs. The fourth, the Delta Project, is somewhat different in that it involves the integration of Demand-Side Management (DSM) with transmission and distribution. Furthermore, the Delta Project does not explicitly involve multi-party transmission. However, we include it because it shows the close interaction between the economics of DSM and transmission and distribution costs, which therefore affects the relative economics of DSM versus, for example, new remote generation requiring transmission.

These four IRPs represent the most explicit treatment of transmission planning in current practice. Compared to the level of detail outlined in Chapter 2, however, the discussion is typically quite limited. As Chapter 4 demonstrates, regulators must adjudicate transmission planning issues when major projects are proposed. Section 3.3 outlines some of the linkages between IRP and such cases. We conclude in Section 3.4 that there will be inevitable feedback and interaction between IRP and these other processes, but that its precise nature is still indeterminate.

### 3.2 Current IRP Practice

#### 3.2.1 Florida Power

Florida Power Company (FPC) is a utility in Central Florida with a peak demand of over 6 GW. FPC's 1991 IRP consists of load forecasts, generation options, and demand-side management plans, as well as the impacts of a new 500 kV tie-line from FPC Northwards to the Southern Company that is to be in service by 1997. The new tie-line contributes to increased reliability through improved stability and access to emergency purchases; allows for continued purchases of 400 MW of firm power from the Southern Company; and, provides for increased economy purchases (FPC 1991).

The tie-line is justified mostly on the basis of emergency support and economy purchases (FPC 1991). The 400 MW of firm power purchases from the Southern Company begins in 1993 and continues until 2010 and represents approximately 10% of the total additional resources needed to meet FPC's 2001 Winter peak demand. In considering the benefits of this significant power purchase, transmission construction costs of the tie-line were essentially considered to be sunk and therefore did not apparently affect purchase decisions. In other words, there was no explicit trade-off of the cost of various transmission capacity options against the benefits of increased purchases from the Southern Company.

### 3.2.2 Nevada Power Company

Nevada Power Company (NPC) is a Southern Nevada utility with a peak load of approximately 2.3 GW that is rapidly growing due to the growth in the tourist and casino industries. Most of the NPC load is concentrated in and around Las Vegas. Transmission needs for access to resources are therefore relatively easy to identify since most potential routes connect radially to Los Vegas as shown in Figure 3-1. Power purchase proposals were solicited from 30 potential suppliers and transmission needs evaluated and compared to NPC's own potential construction options (NPC 1991). Analysis is relatively simple in this case because all connections are radial, and none of the network issues identified in Section 2.3 arise.

### 3.2.3 Niagara Mohawk Power Corporation

Niagara Mohawk Power Corporation (NMPC) is a utility in Central and Upstate New York with a peak demand of over 6 GW. NMPC has issued two IRP's, in 1989 and 1991. Transmission was investigated in the 1991 plan to identify strong and weak areas of the transmission system, describe problems, and propose solutions (NMPC 1991). The NMPC service area was divided into sub-regions and transfer capabilities were investigated

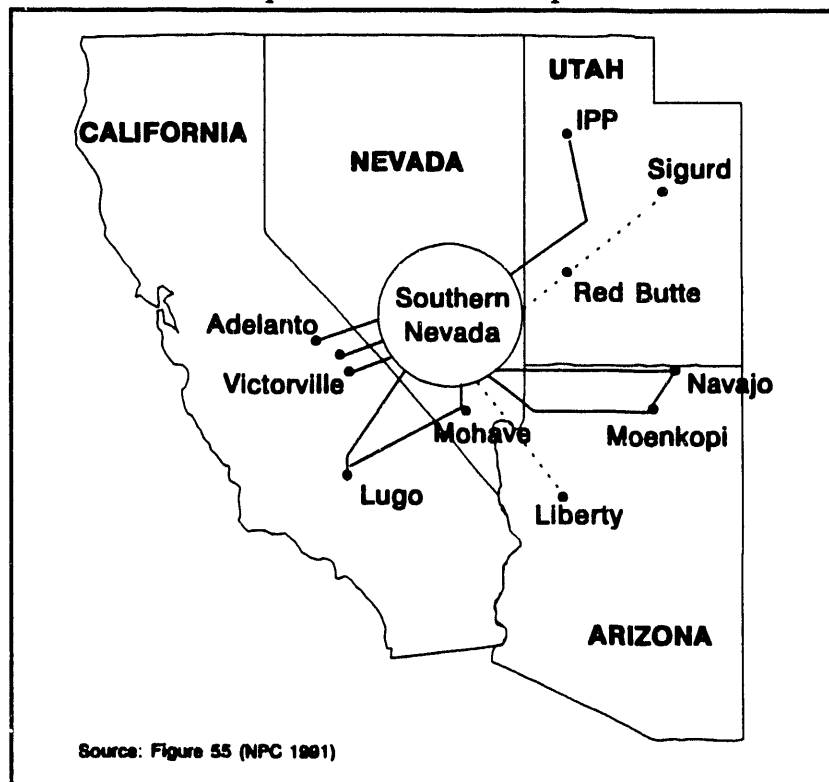

Figure 3-1  
External Transmission Connections to  
Nevada Power Company

to grade the sub-regions on the local capacity to import to loads and to export power from local generation. Five major transmission interfaces:

- Ontario Hydro-New York (OH-NYPP);
- West New York-Central New York (West-Central);
- Northern New York-Central New York (Moses-South);
- Central New York-Eastern Upstate New York (Central-East); and,
- New York-New England Power Pool (NYPP-NEPOOL),

were also investigated to determine capacity for bulk power transmission between areas. Figure 3-2 shows the results of this study, with sub-regions differentiated according to whether projects could be accommodated by existing transmission capacity, could defer the need for expansion, or would increase the need for transmission capacity.

The costs and characteristics of the proposed local transmission reinforcement projects were incorporated into the costs of proposed generation and/or DSM projects in order to develop an optimal portfolio of projects.

### **3.2.4 Pacific Gas and Electric Company Delta Project**

The Delta District is a distribution planning area in PG&E's service territory with a load of approximately 90 MW (Orans 1991). The Delta Project is an integration of demand-side management and transmission and distribution planning for the Delta District. While PG&E has a company-wide IRP, the Delta Project represents an experimental approach to much more detailed analysis of local geographic costs and benefits of load growth and DSM opportunities. Much of the focus is on distribution system expansion costs.

PG&E currently has plans for upgrades of transmission and distribution capacity in the Delta District over the 1990s and into the twenty-first century to accommodate growing demand. Orans (1989) has developed a methodology to evaluate the changes in present worth of the cost of this planned expansion as timing of the planning decisions are changed to accommodate changes in the expected demand trajectory. From this estimate in the change of present worth, temporally and geographically disaggregated transmission and distribution costs due to changes in load can be calculated. These transmission and distribution costs can be used to evaluate whether DSM proposals are economic when introduced at a given time in a given place in the distribution system.

Because DSM can potentially delay transmission and distribution expenditures, the benefits of DSM will be under-estimated if transmission and distribution effects are ignored. In contrast, if transmission costs are ignored for supply-side options, then the costs of these options can be under-estimated. Clearly, this asymmetry can bias the comparison of DSM and supply-side options, particularly if both types of resources are being bid in an auction. The Delta Project represents an initial effort to address coherently the local network costs and benefits of DSM.

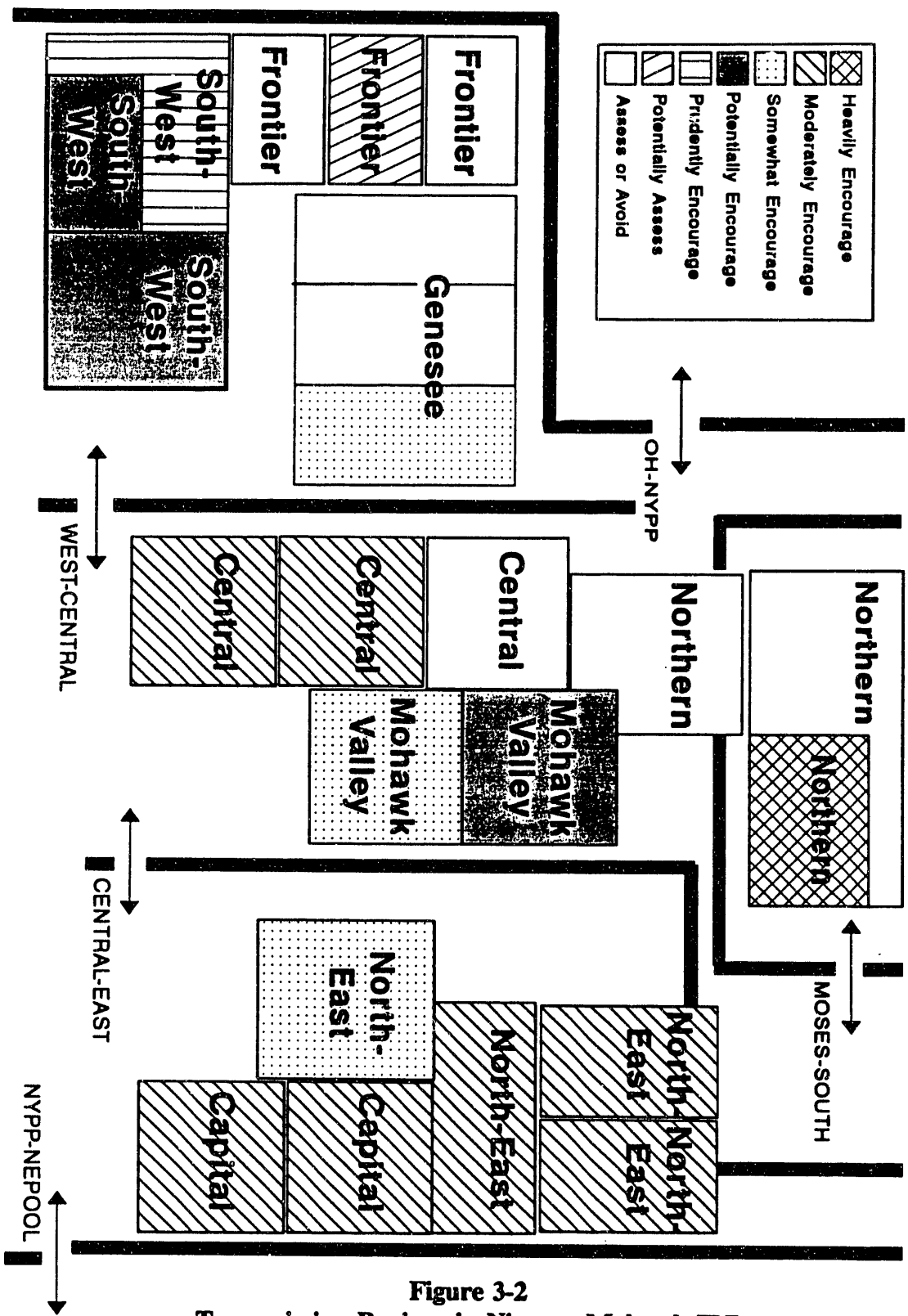

**Figure 3-2**  
**Transmission Regions in Niagara Mohawk IRP**  
 Source: Figure 6-1 of (NIMO 1991)



### **3.2.5 Summary**

Transmission system expansion plans are represented in limited detail in the IRP plans of Florida Power Corporation and Nevada Power Company. This is consistent with standard practice in IRP, where production cost models used to compare alternative resources are generally run as "one-bus" models, i.e. with generation assumed to be directly connected to load without any explicit characterization of the transmission network. This means that transmission costs are typically suppressed when resources are compared. Transmission is only considered when:

1. resources are remote so that radial transmission costs can be directly incorporated into the costs of generation, or,
2. there are known bottlenecks, which a priori limit the projects that are considered in a plan.

For resources which do not fall into these categories, there is no explicit trade-off of resource costs and transmission needs against project benefits. The effect of generation choices on the need and cost of internal network transmission is therefore typically neglected. For systems such as Nevada Power, where most demand is concentrated around a single area, this may not bias the choice of supply options significantly, since the radial transmission costs of most potential suppliers can be easily incorporated into the bid assessment.

Methodologies used by Niagara Mohawk in their IRP plan and Pacific Gas and Electric's Delta Project do treat the costs of transmission in a way that fairly compares among demand and supply-side options. These approaches begin to incorporate location specific costs and benefits into the resource selection process.

## **3.3 The Larger Setting: Linkages Between IRP and Other Processes**

The examples of "conventional IRP" given above show a limited treatment of transmission planning compared both to the range of possibilities outlined in Chapter 2 and the actual cases adjudicated by state regulatory agencies that will be reviewed in Chapter 4. In this section we outline the potential linkages between "conventional IRP" and other processes in which transmission planning occurs. The goal of this examination is to frame the question of whether IRP should or can be confined to the role described in the three utility IRP plans. We formulate these linkages in three ways: (1) the role of state law in defining the authority of regulatory commissions, (2) the regional aspect of transmission planning, and (3) the question of whether planning or competitive processes determine transmission needs or vice versa. None of these questions has definitive answers, but each of them affects the manner in which state IRP processes will ultimately cope with transmission planning issues.

### **3.3.1 The Role of State Law**

The authority of state regulatory commissions over transmission planning is seldom clear and explicit. Where state law defines IRP responsibilities for regulatory commissions, transmission may not be mentioned explicitly. Typical language refers to planning for "resources." Under such language, transmission would have to be interpreted to be one such resource if transmission planning were to be considered integral to IRP. This essentially semantic question is much less important than the more fundamental jurisdictional question, the authority of state commissions over all electric utilities in a state. The most common situation involves a limited domain for the regulatory commission; typically confined to investor-owned utilities and excluding government-owned utilities. The California-Oregon Transmission Project (COTP), discussed in Section 4.3, illustrates problems that can arise when the participants in a large transmission project are not all subject to the same regulatory regime. Conversely, the Wisconsin Advance Plan (WAP), discussed in Section 5.3.1, illustrates the opposite model. The WAP is based on a legislative framework which gives the state regulatory agency authority over both investor-owned and government-owned utilities.

Detailed analysis of the WAP is deferred until later. For the present discussion, its importance is simply that: (1) WAP involves comprehensive transmission planning substantially beyond the limited examples in the three utility IRPs, and (2) to achieve this result unique state legislation is a necessary (but not sufficient) condition. This means that, in principle, conventional IRP might be broadened to include the full range of transmission planning. In practice, however, this alternative depends upon special legal conditions that may not be easily or readily duplicated elsewhere.

### **3.3.2 Regional Issues**

Frequently, transmission planning occurs at the regional level. Beginning in the 1960s and 1970s, utilities formed special study groups to examine future configurations of the regional network involving both generation and transmission capacity expansion. When interstate transmission projects are constructed as a result of such joint planning, individual participants must obtain regulatory approval for the investments involved. Before IRP processes became widespread, there was relatively little attention given to transmission investments by state regulators. Now, it is less clear how the regional aspect of transmission planning will be reflected in the IRP process, which is fundamentally oriented to individual state concerns.

With the exception of the Northwest Power Planning Council, there is no functioning model of a multi-state planning and regulatory activity. There are, however, both formal and ad hoc co-operative planning activities involving state regulators that can complement state level IRP. Where such co-operation has occurred, e.g. the National Association of Regulatory Utility Commissioners (NARUC) regional regulatory affiliates, it has not typically been motivated by transmission planning concerns. Therefore, in the short term regional issues will probably impede the absorption of transmission planning into "conventional IRP."

### **3.3.3 Does Transmission Planning Lead or Lag IRP?**

The case studies in Chapter 4 do not provide much general guidance concerning the linkages between IRP and major transmission projects. In one case, the Consumers Power - PSI line (Sec. 4.5) the relationship of the project to the larger IRP setting became a contested issue. In a general sense, new transmission facilities would expand the set of resources to be evaluated by an IRP. In many cases, however, the need for resources may have motivated new transmission projects. To some extent, this distinction may be a "chicken or egg" question; it is not really possible to say which came first.

A useful analogy is the recent history of pipeline expansions in the natural gas industry. New pipeline capacity in California and New England has been built recently in anticipation of increasing gas demand in those regions. The existence of these projects, however, to some extent has also created demand for their services. Incremental interconnection costs are lower when new transmission or pipeline capacity is available in a region. This will affect siting decisions for private power producers. The Kramer-Victor case, discussed in Section 4.4 below, raises a number of issues involving the interactions between current and future siting decisions, and the scale economies of transmission re-inforcements.

## **3.4 The Future Challenge**

The limited treatment of transmission in "conventional IRP" may or may not represent a stable planning and regulatory model. As more experience is gained with IRP, transmission-related questions will inevitably find a place in the discussion. Regulatory commissions will find that these issues must be integrated in some fashion into the IRP process. One example of this trend is the recent order of the Montana PSC, requiring that transmission costs (both positive and negative and including opportunity costs) be incorporated into resource comparisons (Montana PSC 1992). Exactly how this will be done remains to be seen.

There are reasons to limit the role of regulatory participation in transmission planning and reasons why large scale transmission projects must be accounted for in any integrated plan. It is too early to tell what the best balance may be. The subsequent chapters will draw out in detail some of the issues posed to state regulators by major transmission projects, some of the policy frameworks proposed to deal with those issues and some of the technical analysis issues involved in transmission planning.



## Chapter 4

# Case Studies: State Regulation

### 4.1 Overview

In this chapter, we present case studies of five transmission projects:

1. Second Devers-Palo Verde Line (DPV2);
2. California-Oregon Transmission Project (COTP);
3. Kramer-Victor Line (K-V);
4. Duquesne Light/GPU Joint Venture (DL/GPU); and,
5. Consumers Power-Public Service of Indiana Line (CP-PSI).

The costs and physical characteristics of these lines are summarized in Table 4-1. The total costs of all projects are over one billion dollars. Collectively, with the exception of the

**Table 4-1**  
**Costs and Physical Characteristics of Lines**

Project	Cost /M\$	Voltage /kV	Rating /MW	Length /miles	Cost/(rating.length) /(\$/kW.mile)
K-V	44 <sup>1</sup>	220	1000 <sup>2</sup>	38	1.16
DPV2	260 <sup>3</sup>	500	1200	240	0.90
DL/GPU	316 <sup>4</sup>	500	1500	240	0.88
COTP	414 <sup>5</sup>	500	1600	340	0.76
CP-PSI	58 <sup>6</sup>	345	500	60 <sup>7</sup>	1.94 <sup>8</sup>

*Notes and Sources:*

1. Circa 1990\$ (CPUC 1990a), but excluding estimated cost of tower overbuilding (CPUC90a).
2. Estimate (Verhey 1989b)(Rupp 1990a), but only 630 MW used by Cal Energy and Luz.
3. 1993\$ (CPUC 1988).
4. 1991\$, (Milbourne 1991). Cost includes phase-shifters and series compensation.
5. Circa 1991\$ (CPUC 1991). COTP involves rebuilding some existing lines and cost excludes the cost of acquiring these lines.
6. Circa 1994\$ (Johnson 1992). Cost includes only the section of line in Consumers Power territory and excludes the cost of: the 345 kV to 138 kV step-down transformer at Branch substation; other 138 kV construction; and, the estimated difference between the costs of single-circuit and double-circuit construction.
7. Length includes only the section of line in Consumers Power territory.
8. Excluding the cost of phase-shifters as well as the cost of the 345 kV to 138 kV transformer, the other 138 kV construction, and the cost difference between single- and double-circuit construction yields a cost of 1.24 \$(/kW.mile).

Consumers Power-Public Service of Indiana Line, the costs per unit length and capacity illustrate economies of scale in transmission construction as voltage is increased, consistent with the general observations in Section 2.3. The anomalous cost of the CP-PSI line will be discussed in Section 4.6.

We begin each study with background material to set the context of the project. Then the project is discussed in relation to the issues raised in Chapter 2. We identify the issues from Chapter 2 that are most important in each case; however, we emphasize that almost all these issues appear to some degree in every case study. These projects were selected for study either because their details are reasonably well documented, or because they pose important policy questions, or both.

In the last section of the chapter, we draw together the case studies and highlight the issues that are important in a number of studies.

## 4.2 Second Devers-Palo Verde Line (DPV2)

### 4.2.1 Background

Devers-Palo Verde 2 is a 500 kV line proposed to parallel the existing 500 kV Devers-Palo Verde 1 (DPV1) line on a common transmission corridor. It would add 1200 MW of transmission capacity from the Palo Verde switchyard in Southwest Arizona to the Devers substation in Southern California (CPUC 1988), which are approximately 240 miles apart (Weatherwax et al. 1987a). A schematic map of the proposed line is shown in Figure 4-1.

DPV2 is a joint venture between Southern California Edison (SCE) and some California Municipal Utilities (MUNIs) (CPUC 1988),

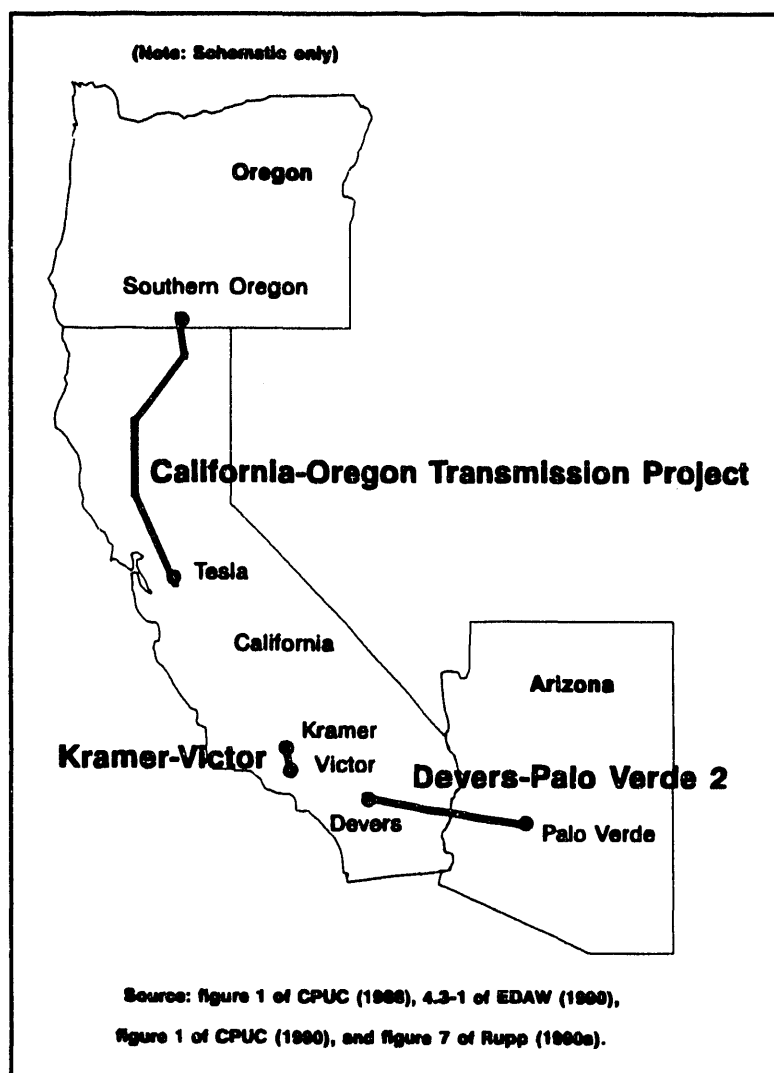

**Figure 4-1**  
Map of DPV2, COTP and K-V

including the City of Los Angeles Department of Water and Power (LADWP). Besides the MUNIs that are joint venturers, several other MUNIs have also arranged for wheeling service over the line. Prior to the proposal of DPV2, there were already several lines running from the Desert Southwest (DSW) to Southern California. DPV2 would strengthen an already significant high-voltage transmission capacity of 5600 MW maximum rating between Southern California and the DSW (CPUC 1988). The proposed objectives of DPV2 were:

1. to increase firm transfer capacity from the Desert Southwest (DSW) for SCE and the other participants;
2. to increase access to economy energy (CPUC 1988); and,
3. for LADWP, apparently also to facilitate future access for remote generation proposals from independent power producers (LADWP 1990).

#### **4.2.2 Significant Issues**

In order to participate in DPV2, SCE requires a 'Certificate of Public Convenience and Necessity' (CPCN) from the California Public Utilities Commission (CPUC). The proceedings at the CPUC were long and complex, and punctuated by several discoveries that completely changed the economics of the project. Figure 4-2 summarizes the regulatory history. There were radical changes in the justification for the line advanced at the CPUC; however, it appears that the decision to build the line was never in dispute for SCE. The series of technical analyses were raised to justify the project to the regulators, not apparently as part of an internal decision process. In the following subsections, we divide the history into the four stages illustrated in Figure 4-2.

##### ***Stage 1: Benefits of Economy Energy and Transmission Revenues***

In SCE's initial case before the CPUC, a June 1990 in-service date was proposed and claimed benefits of the line included:

1. benefits of off-peak economy energy purchases from the Desert Southwest region (DSW);
2. transmission revenues on DPV2; and,
3. increased utilization of other SCE system lines to the West of the Devers substation through increased transfer capability from the DSW (Weatherwax 1987a).

Note that the first issue is a radial benefit, the second is an intermingling of the gains of trade with pecuniary benefits, while the third is a positive network externality.

The CPUC Division of Ratepayer Advocates (DRA) staff argued that the case was flawed because "SCE utilized inconsistent input data, and, in some cases deficient modeling procedures in its analysis" (Weatherwax 1987b) that overstated the benefits of off-peak economy energy

purchases attributable to DPV2. The inconsistencies seem to have arisen because the results of various studies, performed over an extended period, and based on continually revised data such as fuel price forecasts, were combined to support the case for DPV2. While each study could individually be consistent with the range of possible data estimates, the combined case was insupportable. As described in Section 2.2, we label this type of discrepancy an information asymmetry, in this case, evidently internal to the firm, rather than between the firm and the regulator.

***Stage 2: Interconnection Support and the Exchange Agreement***

SCE was instructed to correct the analysis (Weatherwax 1987b) and later submitted further testimony that emphasized another benefit of DPV2, namely the economy of scope of utility interconnection support, which had not featured prominently in SCE's original case. SCE's estimates of the value of interconnection support were subsequently also criticized (Weatherwax 1987b).

Interconnection support was overshadowed in late 1987 when the DRA discovered that SCE had an 'exchange agreement' with the Los Angeles Department of Water and Power (LADWP) (CPUC 1988). The agreement enhanced the benefits of SCE's and LADWP's participation in DPV2, by allowing SCE to:

- use LADWP's Castaic Pumped Storage facility, and,
- purchase economy energy from the Pacific North West (PNW) over LADWP's share of the Pacific Intertie (CPUC 1988),

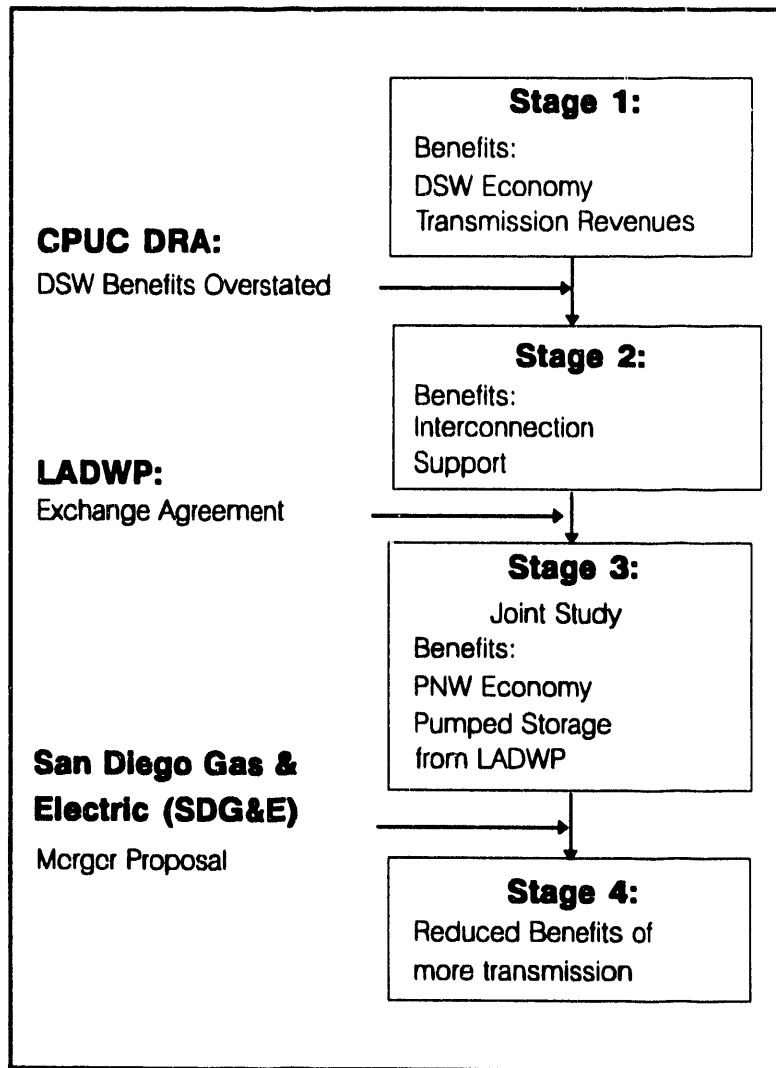

**Figure 4-2  
DPV2 Regulatory Analysis Chronology**



in exchange for allowing LADWP increased access to DPV2 and other parts of SCE's DSW transmission system (Weatherwax 1988). As well as capacity exchanges, there were "additional elements in settlement of other long standing disputes between [SCE and LADWP]" (Weatherwax 1988) concerning, for example, parallel flow.

### ***Stage 3: Joint Study***

Subsequently, SCE and DRA conducted a joint study to resolve data and methodological differences (CPUC 1988). This study included updated assessment of several economic aspects of DPV2 and involved joint development and refining of analytic methods, including analysis of (Weatherwax 1988):

1. loss reduction benefits;
2. stability improvement benefits;
3. the value of NO<sub>x</sub> emission reductions; and,
4. utility interconnection support benefits.

Based on the joint study, SCE's amended application then claimed that the main benefits of the project were from transmission service revenues and production cost benefits, with smaller benefits from improved air quality, reduced losses, improved utility interconnection support, and increased stability (CPUC 1988). As well as the 'real' benefits of the line, there are 'pecuniary' benefits associated with:

- transmission service reimbursements for parallel flow, negotiated as part of the project, and,
- QF payment reductions (CPUC 1988).

Most of the production cost benefits do not arise directly from DPV2, but instead come from provisions in the SCE/LADWP exchange agreement. These benefits are due to (CPUC 1988):

- additional PNW purchases, made possible by the Exchange Agreement 'swap' of intertie access capacity, and,
- use of LADWP's Castaic Pumped Storage Hydroelectric plant as spinning reserve.

Ironically, "SCE's access to attractively priced economy energy from the Southwest actually decreases (until 2005) with the construction of DPV2" (CPUC 1988), because of increased competition for Southwest economy energy available over DPV2 and other lines (Weatherwax 1988).

Because of the large dependence of the viability of DPV2 on the exchange agreement, it is necessary to consider both DPV2 *and* the exchange agreement in assessing the benefits of DPV2: there is an important synergy between the two factors. Sierra Energy and Risk Assessment (SERA) estimates the effect on benefits due to the exchange agreement to be approximately

230 M\$, in 1990\$ (Weatherwax 1988), which is nearly as large as the total capital cost of the line of 260 M\$ (CPUC 1988).<sup>9</sup>

Several alternate cases and scenarios were considered in the DPV2 joint study. Based on these, the DRA has suggested that the revised in-service date of June 1993 (CPUC 1988) proposed for DPV2 by SCE may not optimize the ratepayer benefits and “argues that SCE should not be satisfied with simply creating a cost-effective project; it should seek to maximize ratepayer benefits” (CPUC 1988).

The joint study represents a significant change in the relationship between SCE and the DRA. Before the joint study, on at least two occasions, DRA discovered serious flaws in the SCE’s economic studies. Although SCE certainly used its technical expertise to further its financial goal of ratebased capital, there is no suggestion that the proponents of DPV2 deliberately misled the CPUC; however, it is also not clear that all the errors in the analysis have been identified. Nevertheless, the cooperation between the DRA and SCE in later stages of the application reduced the potential for undiscovered errors in SCE’s case for a CPCN (Certificate of Public Convenience and Necessity).

The joint study process has several other advantages, including:

1. reducing the amount of redundant analytical work in non-controversial issues;
2. avoiding some of the effort of litigation, if agreement can be reached on many issues before the application is filed; and,
3. standardizing the analysis required for a CPCN so that consistent data assumptions are employed,

while maintaining separate perspectives on controversial issues. The CPUC is considering requiring a pre-application joint-study for all applications (CPUC 1988); however, even with the advantages of a joint study, there are still problems with:

- proprietary information;
- the withholding of information; and,
- the volume of data.

Nevertheless, by standardizing the study analysis, more consistent results should be possible.

---

<sup>9</sup> A similar synergistic relationship apparently holds between the proposed ‘DC Expansion’ of the Pacific DC Intertie (CPUC 1988) and the exchange agreement, although the effect on benefits has not been quantified (CPUC 1988).

#### ***Stage 4: The Merger***

Another issue affecting the viability of DPV2 was SCE's 1988 proposal to merge with San Diego Gas & Electric (SDG&E), which owns transmission in the Desert Southwest, including the Southwest Power Link (SWPL). The DRA's analysis suggests that access to SWPL by SCE would obviate the need for new construction in the Desert Southwest (CPUC 1988). The merger would significantly decrease the value of DPV2 to SCE, by giving SCE access to SWPL, which has a "largely empty status" (CPUC 1988), apparently meaning that its capacity is unfilled most of the time. SERA estimates that the merged companies' existing joint system could transfer at least fifty percent of the energy that is planned to be transferred over DPV2 (Weatherwax 1988). However, SERA concludes that DPV2 would still be cost-effective (CPUC 1988).

The California Energy Commission (CEC) independently commissioned a study, performed by Decision Focus Incorporated (DFI), to assess transmission planning in California and surrounding regions (DFI 1990). The CEC/DFI study concurs with SERA that if the excess SWPL capacity could be utilized by SCE, then there would be no need for DPV2 until well into the twenty-first Century under most scenarios for future fuel costs (CEC 1991). While construction of DPV2 will incur costs for current ratepayers, most benefits will not be realized until far into the future. DFI remarks that institutional considerations, such as competition, and not the need for regional transmission capacity may be the driving force behind some transmission projects (CEC 1991).

In the absence of a merger, SDG&E is apparently unwilling to allow SCE transmission access to its Desert Southwest network for economy energy purchases (CPUC 1988): there is an issue here of competition over transmission access between IOUs leading to inefficient utilization of existing transmission. In the DPV2 decision, the CPUC notes that it should examine the operational efficiency of the existing system (CPUC 1988).

#### **4.2.3 Summary**

The significant institutional issues are: competition between transmission owning utilities over access to capacity, pecuniary versus real benefits of transmission revenues, information asymmetries over significant private information concerning transmission capacities and the benefits of transmission access, and standards of assessment of benefits.

The significant technological issues are: radial reinforcement in providing access to the Desert Southwest (DSW), network externalities of parallel flows and enhanced utilization of the network, synergies between a planned project and a contractual agreement, intertemporal allocation of costs and benefits between current and future ratepayers, and economies of scope of utility interconnection support.

The technical evaluation of the benefits brings into question the optimality of the timing of the project and the relationship of planning to the operational efficiency of the existing transmission system.

## **4.3 California-Oregon Transmission Project (COTP)**

### **4.3.1 Background**

The COTP, which would reinforce the Pacific Intertie from the Pacific North-West (PNW) into California, was motivated by the needs of a group of Californian municipal utilities (MUNIs) for greater access to existing PNW generation and, potentially, to facilitate the future connection of non-utility bidders for MUNI supply contracts.<sup>10</sup> The consortium building COTP consists of more than 30 utilities (Harvego 1990), the core of which are the utilities known collectively as the Transmission Agency of Northern California (TANC) (DRA 1990). A schematic map of the project is shown in Figure 4-1.

Existing access to energy from the PNW for TANC utilities is provided through Pacific Intertie AC and DC lines that are owned by the California IOUs and the Los Angeles Department of Water and Power (CPUC 1988). Recently, the utilization factor of the Pacific Intertie by the IOUs has been declining due to:

1. reduced availability of PNW energy as the amount of excess energy in the PNW declines (DRA 1990), and,
2. significant increases in the transfer capacity of the Pacific Intertie through upgrades to existing lines.

However, the TANC utilities apparently believe that they would not receive satisfactory service at acceptable rates over existing surplus firm capacity owned by the IOUs, and COTP was conceived because the "municipal utilities had continually requested but were denied access over the IOU portion of the existing AC Intertie" (CEC 1991). For example, "[i]n 1981, when PG&E agreed that [the Northern California Power Authority (NCPA)] could purchase energy in the Northwest to be transmitted under an interruptible transmission tariff, there were several occasions on which NCPA found an energy source in the Northwest, contracted for it, and obtained available transmission from PG&E. In each of those occasions, NCPA found that, within a few hours, when the PG&E dispatchers located the source of that energy sold to NCPA, the transmission line would be declared unavailable to NCPA and PG&E would then step in and purchase the same energy for its own use" (CEC 1991).

Furthermore, "[n]o [California] entity has authority to enforce joint transmission development between the state's municipal and investor owned utilities" (CEC 1991), nor have voluntary

---

<sup>10</sup> See, for example, Independent Power Report (1991).

efforts at joint planning proved successful for the MUNIs: "One small [California] municipal utility, for example, noted that: 'Joint activities with an entity the size of [an IOU] that has [the IOU's] general approach is something of a misnomer. [The IOU] exercises such muscle in these (planning) activities that [the municipal utility] is greatly overshadowed. To the extent that joint planning takes place, it consists of [the IOU] telling [the municipal utility] what [the municipal utility] will be permitted to do' " (CEC 1991).

Nevertheless, after COTP was proposed by the MUNIs, the California IOUs became interested in participation in COTP. As with DPV2, the IOUs need a Certificate of Public Convenience and Necessity (CPCN) from the California Public Utilities Commission (CPUC) to participate. They were eventually denied a CPCN (CPUC 1991).

### 4.3.2 Significant Issues

With limited wheeling access for MUNIs to existing lines and limited opportunities for MUNIs to participate in joint planning, a central aspect of COTP is the balance of power provided by transmission access: the IOUs naturally want to protect their markets, while the MUNIs want to bypass the IOUs. A straightforward interpretation of COTP is that it is simply a cost that must be incurred by the MUNIs to obtain the benefits of increased competition in the generation sector. The main benefits may be strategic, in forcing more competition in supply markets from other regions, rather than the direct PNW access benefits.

The economic decisions of TANC are not subject to independent oversight (CEC 1991), since MUNIs in California are not regulated by the CPUC. That is, the MUNIs and the IOUs are subject to different regulatory constraints. There are no consistent standards that must be met by all transmission projects. In regional transmission projects there is no reason to believe that the MUNIs will propose better projects or be more cognizant of externalities than the IOUs: there is therefore little justification in regulating the IOUs to a greater degree than the MUNIs in this arena. In fact, since COTP passes through IOU service areas it might be expected that the IOUs would be more sensitive to at least some issues such as the environmental externalities of transmission construction.

The Division of Ratepayer Advocates (DRA) at the CPUC evaluates projects from the perspective of ratepayers of the utilities that are under the jurisdiction of the CPUC, namely the IOUs. The DRA report on COTP indicates that COTP will, on balance, make the three IOUs and their ratepayers collectively worse off (DRA 1990). However, equity participation in COTP is better for the IOUs than a MUNI-only COTP. This is because, given a fixed total capacity for the line, IOU participation in COTP will leave less capacity available to the MUNIs and thereby limit the MUNI access to the PNW. This allows the IOUs to maintain more of their wholesale market: for example, "PG&E acknowledges its desire to maintain as much control of Northwest-related transmission as it can in its CPCN Application" (EDAW 1990). Ironically, the Federal Government encouraged IOU participation in the project (EDAW 1990), although

COTP can proceed without IOUs since TANC has obtained financing and has eminent domain rights (Flynn and Associates 1990).

The DRA recommends that the California IOUs improve the operational efficiency of their transmission networks through increased coordination (DRA 1990). For example, it is possible that the MUNI transmission access benefits of COTP could have been achieved without construction of COTP by, for example, the IOUs selling or leasing entitlements of the existing Intertie to the MUNIs. As with assessment of DPV2, there is a significant question of whether or not the existing network is being used optimally. Whether or not the full MUNI access benefits of COTP could be achieved without construction, the IOUs have a clear commercial interest in limiting MUNI access to existing capacity in order to preclude the MUNIs from purchasing from alternative suppliers and to reduce competition from the MUNIs for power purchases from distant markets. Without transmission access, the MUNIs must purchase power from their native IOU or build new transmission.<sup>11</sup> These costs may have been avoided through a more efficient utilization of the existing network.

Environmental externalities are considered in the DRA analysis and discussed in the CPUC decision (CPUC 1991), suggesting that the net effects of COTP on society were at least of some concern. For example, the conclusion of the DRA report is that total pollution will be increased with COTP, and the CPUC decision also discusses the valuation of pollutants emitted into the air. However, the economic analysis does not indicate if the net effects of COTP on society, including all ratepayers and utilities, and considering all externalities, are negative or positive. For example, pecuniary benefits such as reduced QF payments are included in the 'benefits' in the DRA analysis (DRA 1990) and in-state and out-of-state pollutants are valued differently and arbitrarily. Therefore, the analysis does not indicate if COTP is a net positive contribution to 'social welfare'. To satisfy such a social welfare criterion, the heavy losses to the IOUs (DRA 1990) would have to be more than compensated by even larger benefits to the MUNIs.

In fact, it is not the DRA's mission to assess net societal benefits. Instead, its analysis is limited by the mandate of the CPUC to the perspective of only a segment of the society and only a subset of the externalities (CEC 1991), despite eminent domain being conferred by society as a whole to TANC, presumably for society's collective benefit. That is, the limited perspective of the California PUC does not even extend to all the affected Californian participants and *a fortiori* does not extend to all affected participants. This asymmetric constraint and the inconsistent evaluation of benefits brings into question the ability of the CPUC to make relevant judgments in this case.

The California Energy Commission, as a state planning agency, might be better poised to adjudicate such matters. The Decision Focus Incorporated (DFI) study, sponsored by the CEC and mentioned in the last section, concludes that COTP is justified in the long term in a social welfare sense, considering overall Western States regional welfare (DFI 1990, CEC 1991);

---

<sup>11</sup> For example, in relation to another MUNI sponsored line, Mead-Adelanto, SCE desired to discourage construction in order to avoid MUNI bypass (Mays 1990).

however, in DFI's base-case scenario, and assuming no institutional impediments to optimal transmission utilization, increased PNW-California capacity may not be justified until the period 2001—2005; furthermore, a project the size of COTP may not be justified until the period 2006—2010 (DFI 1990). Various assumptions drive this conclusion, including:

- gas price trajectories,
- coal price trajectories,
- transmission construction costs,
- constraints on out-of-California construction for the benefit of California,
- effects of demand-side management,
- demand growth trajectories, and,
- differences in environmental externality costs between California and other regions.

These assumptions and the conclusions of the DFI study may be questioned; however, the study clarifies the differences between evaluating the benefits of COTP from the MUNI and IOU perspectives, on one hand, and from a regional perspective, on the other.

While long-term PNW-California transmission capacity expansion may be justified, questions remain as to:

1. whether COTP is the best choice of line expansion to improve access to the PNW, and,
2. whether benefits available in the short term justify construction before the turn of the century.

Anecdotal evidence suggests that the constraints on transfer from the PNW may be most effectively removed, not by the construction of more transmission capacity directly between the PNW and California, but by the construction of more capacity in states such as Idaho or Arizona that would alleviate parallel flow problems. That is, while COTP is apparently a radial interconnection, there are significant aspects of network expansion in the project. No less an authority than former Federal Energy Regulatory Commission (FERC) Commissioner Charles Stalon has been quoted in support of this proposition: "Somebody once pointed out to me that one of the problems in parallel flows of Northwest power coming into southern California is the shortage of certain kinds of capacity in the Idaho area. That person insisted that what we really need is more capacity built in Idaho for the benefit of California. But its immediate objective would be to alleviate the overloading of lines in Arizona" (Stalon 1990a).

In summary, the transfer capability from the PNW may be limited by parallel flows that cause overloads on transmission lines that are remote from the Pacific Intertie: "Pacific AC Intertie operations, for example, are frequently curtailed due to counterclockwise loop flow reducing transfers of Northwest firm and economy energy to California" (Hayward et al. 1991). Conversely, "[l]oop flow inhibits some of the intermountain states from increasing transmission capacity, because any such expansion would get filled up from existing Pacific Northwest-to-California transactions" (NARUC 1990).

While the COTP may be a feasible way to increase PNW access, it may not be the optimal project: the most cost-effective way to improve transfer capability from the PNW may be through judicious network expansion of transmission lines that are remote from the PNW. This is an illustration of the "strong line/weak line" externality illustrated by Examples 2 and 4 in Section 2.3.2 above. Other, potentially cheaper, ways to improve transmission capacity from the PNW include:

1. technical fixes, such as described in EPRI's Flexible AC Transmission Systems Study (EPRI 1990), that improve transfer capability without major construction work, and
2. 'stability mitigation' procedures as suggested in (CEC 1991).

The feasibility of other transmission improvements is uncertain; however, it is clear that State-based regulation of transmission is unable to respond in an effective way to such possibilities (Stalon 1990b). Even Federal Agencies involved in COTP have not given consideration to the possibility of such alternatives. For example, the United States Department of Energy and the Western Area Power Administration were two of the three lead agencies for the Environmental Impact Study (EIS) for COTP. Four other Federal Agencies also cooperated in the study. However, no alternative routes or transmission alternatives outside of California were considered in the EIS (USDOE 1988).

Even if some Pacific Intertie expansion is necessary for maximizing welfare, there is still an important question of whether COTP, as proposed, is the optimal transmission project or is optimally timed. For example, "[t]he involvement of the IOU's [sic] and other entities in the project subsequent to the original proposal did not result in an increase in the size of the project, indicating the project may have been oversized in the near term from a municipal utility perspective without IOU participation" (EDAW 1990).

Furthermore, subsequent to the original COTP proposal in 1984, the capacity of the existing Pacific Intertie has been increased through upgrades, while the availability of PNW energy has decreased (CPUC 1991). Because the current Pacific Intertie is under-utilized and will continue to be so due to long-term changes in the Pacific Northwest supply balance (DRA 1990), it appears that the COTP will further decrease the utilization of the Pacific Intertie.

In Section 5.2, we discuss the Western Systems Power Pool (WSPP) and the Large Public Power Council (LPPC) transmission proposal, which advocate market-based pricing for transmission services. Intertemporal unsustainability analysis suggests the potential entry of the MUNIs into the previously IOU dominated transmission market may be incompatible with a market-based pricing mechanism. To demonstrate this potential effect, we paraphrase the analysis in (Baumol 1988), which was described in Example 9 in Section 2.3, as it applies to COTP to show that the conditions for intertemporal unsustainability are satisfied in this case.

We view the IOUs as (sometimes unwilling) incumbent suppliers of transmission to the MUNIs. The MUNIs have traditionally been buyers in the transmission market; however, in proposing



COTP, the MUNIs in TANC have also become potential suppliers of transmission service, although their major anticipated 'buyers' are the TANC members themselves. To analyze the transmission supply market, we view the IOUs as incumbent suppliers and we view TANC as potential entrants.

We assume that demand for transmission service is growing and assume that *some* PNW transmission capacity expansion is called for as part of an optimal transmission plan, given overall social welfare maximization as an objective. Note that the optimal expansion could be carried out, at least in principle, by either the incumbent suppliers or by the entrants. In practice, of course, there may be real differences in construction costs and other fixed costs depending on whether the incumbents or the entrants undertake the expansion; for simplicity, we will assume that these differences are relatively small. Furthermore, because payoffs accrue to different participants, there are differences in pecuniary interests: this is an important part of the MUNI/IOU competition issues discussed above; however, here we are concerned with overall social welfare optimal expansion plans and are not considering the distribution of payoffs.

In setting up prices for transmission, whether bundled as retail rates or as unbundled sales of transmission capacity, IOUs expect to cover costs of transmission in revenues. In addition, for transmission prices to be 'sustainable', there must not be any set of lower prices that yield higher transmission profits. Unless fixed costs of entry, such as legal fees, are high enough, then the analysis in (Baumol 1988) shows that the transmission market is unsustainable. As described above, the DRA analysis (DRA 1990) indicates that there will be considerable unused capacity in the Pacific Intertie if COTP is built, indicating that TANC is capturing incumbent market as well as supplying the incremental market.

Despite the importance of the issue of unsustainability, we emphasize that strategic and long-term access issues are at the heart of COTP. MUNI ownership of COTP allows better access to remote potential Independent Power Producers' (IPP) resources in the PNW. For example, Sacramento Municipal Utility District (SMUD) has recently recommended purchases from two independent power producers in British Columbia (IPR 1991). However, the complexity of the technological issues involved in determining the benefits makes it very difficult to assess the interplay of technological and institutional issues.

### **4.3.3 Summary**

The significant institutional issues are: competition between IOUs and MUNIs over access to existing and planned transmission, asymmetric constraints between IOUs and MUNIs due to anomalies in regulatory jurisdiction, state and regional conflicts and lack of planning jurisdiction and initiatives on a regional scale, pecuniary versus real benefits of QF payments, and standardization of benefit assessment for all utilities.

The technological issues are radial reinforcement to a remote resource to the PNW, yet also negative network externalities due to parallel flow in the whole North-West region, and potential economic unsustainability due to economies of scale coupled to growth. Finally, the technical evaluation of the benefits brings into question the optimality of this large, complicated project. As with DPV2, the relationship of planning to the efficiency of current operation is also in question.

#### 4.4 Kramer-Victor Line (K-V)

##### 4.4.1 Background

California Energy Company (Cal Energy) and Luz International Limited (Luz) are two companies developing generation facilities in the Mojave Desert to sell electricity to Southern California Edison (SCE) under standard contracts for Qualifying Facilities (QFs) (CPUC 1990a). Cal Energy has built two geothermal power plants at China Lake with combined capacity of 150 MW, while Luz planned a series of Solar Thermal generators at Harper Lake, each rated at 80 MW, for a total of 630 MW of independent generation. Luz has brought one unit on-line and planned to build a total of six units (CPUC 1990a). Luz has subsequently entered bankruptcy.

In initial discussions between Luz and SCE in 1986 and 1987 over transmission requirements, SCE proposed a new radial connection between the Luz facilities at Harper Lake and SCE's Victor substation. A schematic of the path of this proposal is shown in Figure 4-3 and we refer to it as Proposal 1. The line would have required a new transmission corridor through untouched desert from Harper Lake to Victor. SCE's initial proposal to Cal Energy apparently also involved radial connections from China Lake via Inyokern Substation to Victor (Verhey 1990). From Victor, there is ample transmission capacity to SCE's Lugo substation, which is,

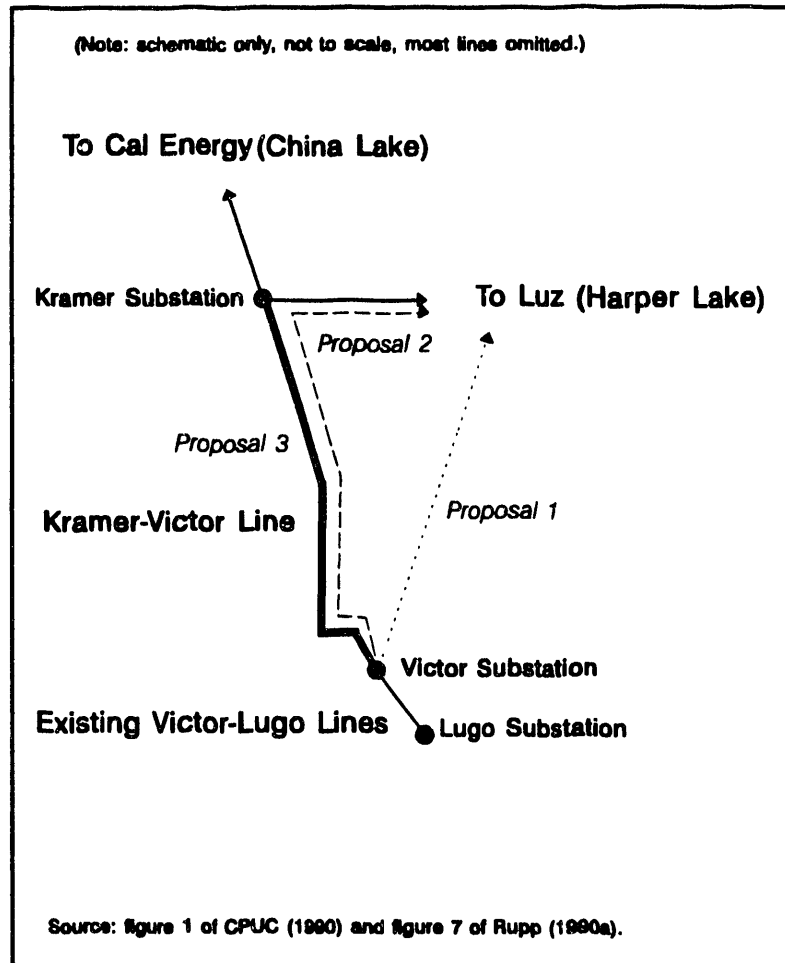

**Figure 4-3**  
**Map of Pertinent Lines in Kramer-Victor Area**

in turn, interconnected to SCE's 500 kV system that provides bulk connection to SCE's load centers.

Proposal 1 consisted of two double-circuit 115 kV lines with total thermal capacity somewhat larger than the maximum output of the Luz units. The lines could be built one at a time as the Luz capacity increased so that the risk of unused capacity would be small. With all four lines built, the N-1 criterion would be satisfied by the lines. The proposal is summarized in Table 4-2a, with total costs estimated in July 1987 at 55 M\$. Consistent with earlier California Public Utility Commission (CPUC) decisions (Alahydoian and Comnes 1990), it is reasonable to assume that the total costs of Proposal 1 would have been allocated to Luz if it had been adopted. However, Luz found the cost to be unacceptable (Verhey 1989a).

Subsequently, SCE proposed two further transmission plans to Luz (Verhey 1989a):

- Proposal 2: A double-circuit 220 kV radial line from Harper Lake to Victor, with most of its length paralleling existing lines from Kramer to Victor,<sup>12</sup> and,
- Proposal 3: A 12 mile, 220 kV single-circuit radial line from Harper Lake to Kramer, interconnection with the SCE system at Kramer, and a 38 mile, double-circuit 220 kV line from Kramer to Victor, having a rating of approximately 1000 MW (Verhey 1989b)(Rupp 1990a).

The paths of these lines are shown in Figure 4-3 and the proposals summarized in Table 4-2b.

There are several existing lines in the Kramer-Victor area that are not illustrated in Figure 4-3. These lines are already heavily loaded even in the absence of additional generation (CPUC 1990a). At peak times these lines are apparently loaded to near their thermal capacity so that the N-1 criterion is not satisfied. In arguing over cost allocations, Luz contended that the construction of Kramer-Victor would improve the reliability of the system by making it more nearly satisfy the N-1 criterion. However, SCE argued that the N-1 criterion was not applicable because: (1) the area has only a small load, and, (2) there is ample spinning reserve in the rest of the system to make up for loss of supply in the area due to a transmission outage.

To analyze the transmission capacity, we adopt SCE's argument and consider thermal capacity only, neglecting the N-1 criterion. Under this assumption, the Kramer-Victor line in Proposal 3 had ample capacity for moving both Luz' and Cal Energy's generation from Kramer to Victor. Its rating of approximately 1000 MW would leave 370 MW of uncommitted capacity on the line. Luz and Cal Energy were responsible for the radial lines from their facilities to Kramer; however, these radial lines were relatively shorter than radial lines all the way to Victor. Proposal 3 was eventually adopted and was brought before the California Public Utilities

---

<sup>12</sup> Under one interpretation of Proposal 2, there would have been a double-circuit line from Kramer to Victor. The two circuits would split at Kramer into two single-circuit lines, with one going to Harper Lake and the other to China Lake.

**Table 4-2  
Kramer-Victor Transmission Proposals and Decision Chronology**

(a): July 1987, original Proposal from SCE (Verhey 1990).

Proposal 1	Cost /M\$	Allocation to Luz/M\$
Two double-circuit 115 kV radial lines: Harper Lake-Victor (39 miles) and substation upgrades.	55	55

(b): April 1988, two further alternatives added to original proposal by SCE (Verhey 1990).

Proposal 2	Proposal 3
Double-circuit 220 kV radial line: Harper Lake-Victor.	Single-circuit 220 kV radial line: Harper Lake-Kramer, interconnection at Kramer, double-circuit 220 kV Kramer-Victor line, and substation upgrades.

(c): September 1990, final form of Proposal 3, including interim 115 kV rebuild and allocation of costs (CPUC 1990)(Verhey 1989b).

Final Proposal 3	Cost /M\$	Allocation to Luz /M\$	Allocation to Cal Energy /M\$	Allocation to SCE /M\$
Single-Circuit Harper Lake-Kramer 220 kV (12 miles)	10 <sup>1</sup>	10	0	0
Operation and maintenance costs at Kramer	2 <sup>2</sup>	2	0	0
Metering and telemetering	3.5	3.5	0	0
Double-Circuit Kramer-Victor 220 kV (38 miles), tower overbuilding, interconnection, substation upgrades	50	22	10.5	17.5
Kramer-Victor 115 kV rebuild	13	6.5	6.5	0
<b>Total</b>	<b>78.5</b>	<b>44</b>	<b>17</b>	<b>17.5</b>

<sup>1</sup> Estimate based on cost of Kramer-Victor line (50 M\$), less cost of tower over-building (6 M\$), and multiplied by ratio of lengths (12 miles/38 miles) and by the ratio of the costs of single-circuit to double-circuit lines (1/1.43) (EPRI 1986).

<sup>2</sup> Estimate based on operations and maintenance costs being equivalent to two man-years per year (0.2 M\$) multiplied by factor of 10 to obtain net present value.

Commission (CPUC) for a Certificate of Public Convenience and Necessity (CPCN). The approximate location of the project is shown in Figure 4-1.

Because of the heavy existing load, and as an interim measure before the Kramer-Victor line could be approved at the CPUC and constructed, Luz and Cal Energy agreed to contribute to the costs of rebuilding a 115 kV line between Kramer and Victor owned by SCE (CPUC 1990a). The 115 kV rebuild provided capacity for the initial generation capacity until a larger transmission line could be built. The allocation of the costs of the Kramer-Victor 220 kV and 115 kV lines and substation upgrades became the basis for dispute at the CPUC.

#### **4.4.2 Significant Issues**

Analysis of K-V is complicated by the interaction of the economies of scale of transmission construction and scope of transmission operation with the uncertainty of future load growth, since the 370 MW of uncommitted capacity on the K-V 220 kV line yields benefits only if it is eventually used. K-V may by itself promote growth in the area by reducing the cost of grid interconnection compared to places without such access, potentially accelerating growth in the area. Evaluation of line benefits also depends on whether or not the line has 'network' effects such as improving the reliability or reducing the losses. As indicated above, there was argument over these issues.<sup>13</sup>

Some of the existing lines in the area are currently used to transfer power Northwards from the Lugo substation to loads supplied from the Victor substation. The planned Luz and Cal Energy units were to eventually supply the load at Victor, with the balance of their generation flowing from Victor Southwards towards Lugo (CPUC 1990a). The lines between Victor and Lugo therefore exhibit the economies of scope that are intrinsic to two-way flow on transmission lines: while initially built to support South-to-North flow, they would eventually be used to support North-to-South flow as the relationship of generation to load centers changed. If these lines had not already been present in the SCE system, then the cost of interconnection between Luz and Cal Energy, and SCE may have been somewhat greater.

The towers for the Kramer-Victor 220 kV line are to be overbuilt relative to the minimum requirements for QF interconnection, so that an additional set of conductors can be added to each circuit in the future enabling "SCE to meet any unanticipated future need without constructing additional towers or further taxing an already crowded transmission corridor" (CPUC 1990a).

Edison is prudently taking advantage of economies of scale in transmission construction (CPUC 1990a) and the towers are SCE's standard design; however, since "SCE does not currently anticipate needing additional transmission capacity in this corridor" (CPUC 1990a), SCE may

---

<sup>13</sup> The case is also muddled by the business association of Cal Energy with SCE (CPUC 1990a).

be predicting that the Kramer-Victor line *itself* will promote load growth in the area that, in the absence of the line, would not have otherwise occurred. A nearby load area, San Bernadino County, has very high growth (Rupp 1990a). It is conceivable that the high growth rate would spread to the Kramer-Victor area in the presence of convenient transmission access. To the extent that growth in this area is on balance beneficial, this eventuality would be a positive externality of transmission construction.

Because utilities have been obliged under PURPA to take QF power at a price somewhat independent of location and transmission costs, but must build lines to support power flows, utilities naturally want to recover the cost of transmission. The regulatory apparatus has been forced to allocate the benefits and costs of transmission.

In its decision, the CPUC advocates the allocation of incremental costs and potential benefits of the tower *overbuilding* to the ratepayers (CPUC 1990a). That is, the ratepayers pay for the incremental cost of overbuilding and reap all the economies of scale. Since the remaining costs are to be allocated between the ratepayers, Luz, and Cal Energy, it is arguable that Luz, Cal Energy, and SCE ratepayers should *all* share in the benefits of the economies of scale in construction. For Luz and Cal Energy to share in the economies of scale, somewhat more than the incremental cost of overbuilding should be allocated to the ratepayers. We will see in Section 4.5 that economies of scale in the Duquesne/GPU line are shared amongst all the participants. Note that the costs of the line overbuilding are being allocated to current ratepayers, while benefits can only accrue to future ratepayers.

Under some interpretations of previous CPUC decisions, the costs of Kramer-Victor excluding the incremental cost of overbuilding are to be allocated on the basis of system-wide benefits produced by the line, potentially including benefits due to, for example:

- reduced line losses;
- system security and reliability;
- emergency support; and,
- enhanced transfer capability.

On even the first issue, however, “[t]he parties disagreed as to whether change in losses should be measured across the entire SCE network, or on a basis which is isolated to the Kramer-Victor area. They disagreed as to whether the analysis should be done with the new QF generation included or not included. In addition, they disagreed as to whether or not the line loss credits included in utility payments to QFs should influence the analysis in any way” (CPUC 1990a). Network characteristics of the line are ignored if the assessment is restricted to changes in losses in the Kramer-Victor area only. Figure 4-3 omits many of the lines in the area and the Kramer-Victor line may have a noticeable effect on flows in these lines and throughout the SCE system, therefore contributing to network loss reduction (Rupp 1990b).

As we have remarked earlier, there are currently no national standards for the assessment of the costs and benefits of transmission, which furthermore depend on a considerable amount of information that is private to the utility, such as:

- line loadings and the amount of excess transmission capacity in the area;
- the availability of transmission corridors;
- the effect of the 630 MW of Luz and Cal Energy generation on unit commitment and generation levels at other generators, in particular, the changes in generation at SCE's Coolwater plant (Rupp 1990a)(Rupp 1990b);
- line impedance data for loadflow analysis to assess changes in losses; and,
- growth estimates for the Kramer-Victor area.

Consequently, the allocation of costs and benefits has been extremely difficult.

A general observation is that there are both system-wide and project-specific effects of the Kramer-Victor line: it has both network *and* radial characteristics. However, the line possesses economies of scale and scope that make the allocation of benefits dubious at best. Litigation and delay are almost certain consequences. Luz contends, for example, that even negotiation over a 'method of service' to interconnect Luz and SCE was used by SCE to delay rather than facilitate interconnection (Verhey 1990). Luz also argues that the 115 kV rebuild was necessitated because of delays in the construction of the 220 kV line caused by SCE (Verhey 1990).

The final costs and allocations of Proposal 3, including the line costs and other upgrades, are shown in Table 4-2c. Comparing Tables 4-2a and 4-2c, it is clear that Luz' final cost allocation of approximately 44 M\$ is more favorable to it than the initial allocation of 55 M\$. It is this 20% reduction in allocated costs that drove Luz' interest in the alternatives to Proposal 1.

Proposals 1 and 2 were radial solutions, while Proposal 3 is a network solution to the transmission needs of Luz and Cal Energy. In the following paragraphs, we will analyze the social welfare implications of the difference between Proposals 1 and 3.

Under either proposal, Cal Energy would also build radial transmission capacity from China Lake to Kramer. To compare the costs of Proposals 1 and 3, therefore, we can omit the cost of the line from China Lake to Kramer. If Proposal 1 were adopted, additional radial capacity would also be required from Kramer to Victor for Cal Energy, while if Proposal 3 were adopted, then the China Lake-Kramer line would terminate and interconnect at Kramer.

To estimate the cost of the radial connection between Kramer and Victor for Proposal 1, we assume that the upgrades to the existing Kramer-Victor 115 kV line would have provided adequate incremental capacity to transmit all of the capacity for Cal Energy. As this line was built anyway as an interim measure, it is reasonable to include it in the complete specification of Proposal 1 as well as of Proposal 3. From Table 4-2c, this yields a cost of 13 M\$. Adding this to the total cost of Proposal 1 from Table 4-2a yields a total cost of radial connections for

**Table 4-3**  
**Summary of Economies of Scale in Kramer-Victor**

Transmission Plan	Cost/ M\$	Per Unit Cost /(\$/kW mile)
Radial: Proposal 1 + Upgrades to Kramer-Victor 115 kV for Cal Energy	68	2.8
Network: Proposal 3 - Tower Overbuilding	72.5	1.7
Difference: 370 MW of Kramer-Victor 220 kV Capacity	4.5	0.3

Luz and Cal Energy of 68 M\$, (excluding the cost of the China Lake to Kramer capacity.) The average cost of this capacity is 2.8 \$/kW mile, based on the Harper Lake-Victor lines being rated at 480 MW in total and the Kramer-Victor rebuild increasing capacity by 150 MW.<sup>14</sup>

The total cost of Proposal 3 is 78.5 M\$, but this includes 6 M\$ of tower overbuilding that is not necessary for the QF interconnection. Therefore, for comparison purposes, we estimate the cost of Proposal 3, excluding the tower overbuilding, to be 72.5 M\$. The average cost of this capacity is 1.7 \$/kW mile, based on the Harper Lake-Kramer line being rated at 480 MW and the Kramer-Victor 220 kV line being rated at 1000 MW.<sup>15</sup>

The difference between the two total costs is 4.5 M\$. The difference in transmission capacity between the two Proposals is approximately 370 MW of additional capacity between Kramer and Victor. The incremental cost of this capacity is 0.3 \$/kW mile. SCE has paid more than the incremental cost since it was allocated 11.5 M\$ of the costs (again excluding tower overbuilding). However, at 0.8 \$/kW mile, this allocated cost is at the low end of the distribution of average costs in Table 4-1, and is considerably below the average cost of the Kramer-Victor 220 kV line itself. These figures are summarized in Table 4-3.

SCE argues that it does not anticipate using the 370 MW of incremental capacity on the double-circuit Kramer-Victor line. However, SCE insisted on tower overbuilding, despite this incremental capacity, suggesting that SCE values the incremental capacity at far more than the

<sup>14</sup> Here we are assigning ratings to the lines equal to their required loading, because excess capacity in a radial line to a remote generator is not easily sold or otherwise used. This may underestimate the potential for using excess capacity on the Kramer-Victor 115 kV rebuild.

<sup>15</sup> Here we assign ratings equal to loading for radial lines, but consider the actual thermal capacity for network construction since we are considering the possibility of being able to utilize the excess capacity on network lines.



allocated cost of 0.8 \$/kW mile due to expectations of future load growth. Under this interpretation, the network solution of Proposal 3, which takes advantage of economies of scale of construction, is superior to the radial solutions because it provides for Cal Energy, Luz, and future load growth at a lower overall cost than would be possible with the radial solutions. To see this, note that:

1. while Proposal 1 was cheaper overall than Proposal 3, (68 M\$ versus 72.5 M\$) it did not provide any additional capacity, and,
2. while Proposal 2 would have cost approximately the same as Proposal 3, the use of radial connections would not have provided any additional capacity between Kramer and Victor.

In proceedings such as Kramer-Victor, there is the potential for dramatic changes in the estimates of costs and benefits of the transmission lines, since the utility has a disincentive to reveal the true benefits and costs of the line in advance of signing a QF contract if it believes that it can later have the costs allocated to the QF. SCE's denial of the benefits of incremental capacity may be an example of this strategy. In contrast, the "QFs would like to know what the constraints [and benefits] are and what they can do about them up front so that they can take transmission issues into consideration in the proposal phase. As the process works now, transmission issues are left for later consideration and can make an otherwise economic project not viable" (Alahydoian and Comnes 1990).

This problem is generic to any contract for supply by a non-utility generator that only considers the cost of transmission as an after-thought and not as part of the initial decision process. There is no incentive for the buying utility to make or reveal an accurate estimate of transmission costs and benefits nor to follow a consistent policy for access to and pricing of transmission. It is natural for a utility in this position to argue, after the QF contracts have been signed, that the cost of transmission reinforcements must be allocated to the QFs, even where the utility's allocation policy differs between projects (Rupp 1990a).

Unfortunately, such inconsistencies have been the norm for QF contracts (Alahydoian and Comnes 1990), although recent bidding proposals address this issue more coherently (Shirmohammadi et al. 1991, Staschus et al. 1991). We will discuss one of these proposals, the Pacific Gas & Electric Multi-Attribute Bidding Framework in Section 5.2.

Even if the allocation issue is resolved, the issue of integrating QF and IPP needs into long-term transmission planning remains problematic since utilities typically have less time between announcements of QF plans and proposed in-service dates than they would have with internal utility plans. The interim 115 kV rebuild was apparently necessitated by time pressures. Use of FACTS technology, as discussed in Section 2.3, provides a possible solution to this problem by temporarily increasing transmission capacity until more permanent solutions become available. A further advantage of FACTS is that it also delays commitment to permanent transmission projects therefore lessening the risk of stranded capital in the event of the QF bankruptcy, as occurred in this case.

Because Luz and Cal Energy were proposing projects at approximately the same time, SCE was eventually able to develop a plan that accommodated them both by taking advantage of economies of scale. In general, however, the joint transmission needs of QFs or IPPs may not appear with such convenient timing so that opportunities for taking advantage of economies of scale may not become evident until construction has already begun and the opportunities foregone. While competition in the generation sector was not at issue in the Kramer-Victor case, proposals such as the Pacific Gas & Electric Multi-Attribute Bidding Framework are designed to take advantage of competition in the generation sector. We discuss the trade-off between the potential gains of competition in the generation sector and the potential losses in transmission economies in Appendix A.5.

The Kramer-Victor line has excess capacity compared to the needs of Luz and Cal Energy. Lumpiness of transmission construction has dictated that SCE obtain CPUC approval to invest in and ratebase transmission in excess of that needed by Luz and Cal Energy. On the other hand, while Luz and Cal Energy have agreed to pay for considerable transmission upgrades, they apparently have no rights to the network transmission they have paid for, other than the right to sell electricity at their interconnection to the SCE system. Luz and Cal Energy were evidently unsatisfied with the agreements, but acceded to them to hasten the already drawn out process of gaining access to transmission. Delays by SCE in arranging for interconnection seriously affect the financial viability of both firms and may have contributed to Luz' bankruptcy. As remarked above, Luz contends that it was forced into paying for interim measures that were caused by SCE's delays. The settlement thus paradoxically combines elements of Averch-Johnson behavior (Averch and Johnson 1962) in overbuilding transmission, while also limiting competition by limiting access to that transmission.

#### **4.4.3 Summary**

The significant institutional issues are: competition between IOUs and QFs over allocation of costs of transmission, information asymmetries concerning operation of the system and benefits of new capacity, and lack of standards for assessment of, among other things, loss benefits.

The technological issues are: network versus radial reinforcements (Proposal 3 versus Proposals 1 and 2), positive externalities due to increased transmission access in the area, economies of scale in building a single large transmission project to accommodate two QFs instead of two smaller radial projects and also involving intertemporal allocation of costs and benefits of the incremental capacity and the tower overbuilding, and economies of scope of transmission operation.

The delay between the announcement of Proposal 1 and Proposals 2 and 3 illustrates the difficulty of planning for QF transmission needs. Particularly where several projects are proposed at different times in a single region, it may be very difficult to plan the network to take advantage of economies of scale. This is discussed in detail in Appendix A.5.

## 4.5 Duquesne Light/GPU Joint Venture (DL/GPU)

### 4.5.1 Background

In the mid 1980s, the steel industry collapsed in Pittsburgh, reducing Duquesne Light Company's industrial baseload demand by over 700 MW. Concurrently, Duquesne was completing construction of two nuclear power plants (DLC 1990), which exacerbated Duquesne's problems by increasing the baseload capacity just as baseload demand was decreasing. Duquesne subsequently closed down two existing fossil fuel plants:

- the Phillips Station, which is coal-fired with 300 MW capacity, and,
- the Brunot Island Combined Cycle Station, which is gas-fired with 267 MW capacity (DLC 1990),

and removed them from ratebase. The capital costs of these plants is a sunk liability of Duquesne's shareholders.

A large potential market for Duquesne's excess power exists to the East of its service territory, representing an opportunity to recoup some of the investment in the Phillips and Brunot Island Stations. Duquesne proposes reopening the Phillips and Brunot Island Stations and selling their energy and capacity. However, access to the market is limited because of transmission constraints, including severe parallel flow constraints (DLC 1990). To increase transmission capacity in order to sell generation capacity, Duquesne and General Public Utilities (GPU) have proposed the joint construction of a single-circuit 500 kV line with phase-shifters and series capacitor compensation between Pittsburgh and Harrisburg (DLC 1990). A schematic map of the proposed line is shown in Figure 4-4.

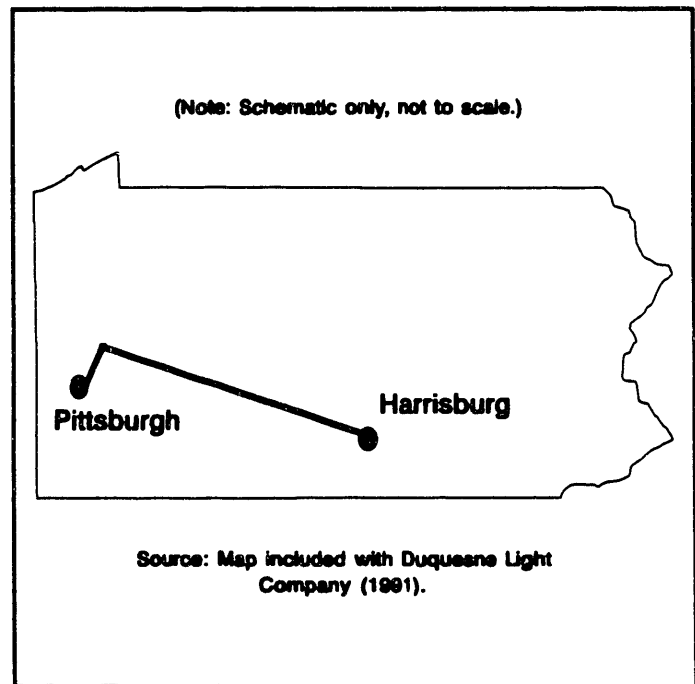

**Figure 4-4**  
**Map of Duquesne/GPU Joint Venture**

## 4.5.2 Significant Issues

There are elements of both radial and network reinforcement in this line since it serves to increase Eastward transmission capacity, but also utilizes phase-shifters to control parallel flow. Economies of scale in construction encourage the building of a 1500 MW line, which is approximately three times the necessary minimum capacity needed to transmit power generated at the Phillips and Brunot Island stations from Pittsburgh to Harrisburg. The capital cost of the transmission will be allocated to owners on a pro rata basis. GPU will own 1000 MW of the capacity and will transmit the Phillips and Brunot Island energy for Duquesne, with Duquesne paying GPU for transmission service (DLC 1990). There is a synergy between the line and Phillips and Brunot Island Stations, since the presence of both is necessary for sales to an Eastern market.

The other 500 MW of capacity will be owned by Duquesne. Its original proposal was to treat this capacity as an essentially unregulated project and exclude it from ratebase. Subsequently the Pennsylvania PUC determined that this capacity would be treated as a traditional regulatory asset (PaPUC, 1992). Independent of the regulatory treatment, Duquesne "is proposing to make its 1/3 interest available to wholesale customers on a nondiscriminatory basis" (DLC 1991), and is planning to auction available capacity. The minimum bid price will be the cost of service. Excess revenues will be credited to customers. The goal of the auction procedure is to maximize the economic efficiency of the capacity allocation. Successful bidders able to reassign or sell their entitlements, making a secondary market possible (DLC 1991). A secondary market would help in assuring that Duquesne does not have monopoly power in the transmission market.

Duquesne and GPU filed their joint submission to FERC in June 1992. The proposed auction arrangements allow bids on a \$/kW basis for any range of years and range of desired transmission service quantities. That is, each bidder submits a bid price in \$/kW, a start date and a finish date for the service, and a minimum and a maximum acceptable quantity of transmission capacity. Winning bidders are allocated an amount of capacity between their minimum and maximum acceptable quantity for the full period between their start and finish dates. All other bidders are allocated zero capacity.

The winning bids are chosen to approximately maximize the value of the bids, subject to the line capacity limit and the bidders' desired quantity constraints. The cost charged for the capacity depends on the bid cost of the marginal losing bidders, so that the auction is like a second price auction. (Operation and maintenance costs are charged separately.) The proponents of the auction argue that in such an auction, bidders are motivated to bid a price equal to their value of service. Consequently, maximizing the value of the winning bids will maximize the *ex ante* value of the transmission service (Hogan 1992). A working secondary market would further improve the allocation of the capacity.

The minimum acceptable quantity (MAQ) constraints in the bids pose special problems for the auction. In the case that the MAQs were zero for all bidders, or if they are neglected, the problem of maximizing the value of the winning bids is a linear program, which can be solved

quickly with widely available software. Non-zero MAQs make the problem of maximizing the value much more complicated.

Duquesne proposes using a heuristic to approximately optimize the value. In outline, the heuristic involves interactively solving the value maximization problem neglecting the MAQ constraints; checking if all the MAQ constraints are satisfied; and, if not, eliminating from consideration one of the bids with an unsatisfied MAQ constraint. The procedure is repeated until all the MAQ constraints are satisfied by the remaining bids (Hogan 1992).

The heuristic algorithm delivers a set of bids with MAQ constraints satisfied. It does not necessarily deliver the best set, but its proponent argues that in practice the sub-optimality is not significant and that the algorithm prevents bidders from benefitting from gaming of bids that might occur if the true optimum was sought (Hogan 1992). The heuristic may in general reject some bids with non-zero MAQ constraints that would have formed part of an optimal set of bids, and may accept some bids having no MAQ constraints that would not have formed part of an optimal set of bids.

It is reasonable to suppose that utilities bidding for capacity to buy or sell economy energy will not have significant MAQ constraints, while IPPs needing transmission service to deliver capacity are more likely to have MAQ constraints. Because of this difference between utility and IPP bidders, and because of the potentially adverse treatment of bidders with MAQ constraints, there is a potential bias against IPP bidders in the auction. Despite this problem, however, the proposed auction may be the best compromise solution.

There are also some other issues that arise from the auction, but which have not been completely resolved. For example:

- the treatment of bids for capacity in years that are far into the future, and,
- the obligations on a winning bidder to sign a contract.

The first issue is problematic if bids for far-future transmission do not fill available capacity. A bidder could offer a very low price and still win capacity. Since the capacity will be ratebased, if there is insufficient demand, costs will be recovered from ratepayers. The second issue may be very problematic for IPPs that are successful in bidding for transmission capacity, but fail to obtain a contract for sale of their generation. The IPP may then be left with transmission capacity it does not need. The proposed secondary markets for capacity may alleviate this problem.

Under the original proposal the presence of information asymmetries between Duquesne/GPU and the Pennsylvania PUC concerning the risk of unsold transmission capacity, raises questions about manipulative behavior. Clearly, the constraints on the regulated and unregulated operations of the line would be different. If Duquesne and GPU know they can profitably sell the excess capacity at market rates, then they would maximize profits by spinning off the excess capacity to an unregulated venture. If they know that there are significant risks in marketing

**Table 4-4  
Annual Revenues for 500 MW of Transmission Service**

	Duration <sup>1</sup> /hours/yr			
	1000	3000	5000	8000
Price <sup>2</sup> /(mills/kWh)	Annual Revenue/M\$			
2	1.0	3.0	5.0	8.0
5	2.5	7.5	12.5	20.0
7	3.5	10.5	17.5	28.0

*Notes:*

<sup>1</sup> 8760 hours is one year.

<sup>2</sup> The range of transmission prices charged to the Sacramento Municipal Utility District by Pacific Gas & Electric during the experimental phase of the Western Systems Power Pool was 2–7 mills/kWh (Schori 1991)

the capacity, they would want to ratebase the line to assure returns that are more independent of utilization. However, the Pennsylvania PUC may not have adequate information to accurately assess the riskiness of the potential transmission investments.

Ameliorating this concern is the observation that because of the cost allocation, any overbuilding in the unregulated part of the project will contribute benefits to the regulated parts through shared economies of scale. To the extent that the unregulated part of the transmission project is truly a shareholder responsibility, while ratepayers get some of the economies of scale, it may not be appropriate for the regulatory apparatus to review the size of the excess capacity. Because of the novelty of the original arrangement, it is important that the contractual arrangements avoid any possibility of ratepayer liability for losses on the unregulated part of the line. Furthermore, the owners should be prevented from shifting sales of transmission capacity between the unregulated and regulated parts. The ratebasing solution adopted by the Pennsylvania PUC makes these concerns moot. Consumers bear the marketing risk under ratebasing, and get the opportunity to earn excess revenues.

The revenues from the transmission are unlikely to be excessive as the following calculation indicates. Table 4-4 shows the annual revenues for various transmission prices and durations. The range of prices is taken from comments in (Schori 1991) concerning market-based transmission prices in the Western Systems Power Pool, to be discussed in Section 5.2. Suppose Duquesne can sell 500 MW of transmission service for 8000 hours per year at 5 mills/kWh. The revenue would be 20 M\$, which is approximately adequate to cover the 117 M\$ capital cost of its share of the line.

There is an environmental concern about the emissions of the ageing, but rehabilitated, Duquesne plants; however, the line itself is planned to minimize direct environmental impacts.

As supporting justification for the line, Duquesne is claiming the positive externalities of indirect jobs created by the line construction.

### **4.5.3 Summary**

The significant institutional issues are the asymmetric constraints on ratebased and unregulated parts of the project and the information asymmetry over the potential profitability of the transmission investment. The technological issues are network and radial reinforcement, positive externalities due to transmission construction, negative externalities due to parallel flows, synergies between the line and existing generation, and economies of scale coupled to an uncertain potential market. Since there are information asymmetries concerning the profitability of the project, the optimality of the size of the project is open to question; however, as we have remarked, if the risk of over-building is borne by Duquesne shareholders and not ratepayers, then this uncertainty should not necessarily be of great concern. The auction arrangements are designed to encourage allocation of capacity to transmission customers with the highest bid value; that is, to optimize *ex ante* efficiency. A secondary market would optimize *ex post* efficiency.

## **4.6 Consumers Power Company-PSI Line**

### **4.6.1 Background**

Consumers Power Company (CP) and PSI Energy, Inc. (PSI, formerly Public Service Company of Indiana, Inc.) are proposing to interconnect their systems at 345 kV through a 125 mile line from the Battle Creek Substation in Michigan to the Beaver Dam Switching Station in Indiana. According to CP, the main benefits of the line are due to economy energy purchases from PSI and reinforcement of the 138 kV system in South-Central Michigan. A schematic map of the proposed line is shown in Figure 4-5.

Each utility is planning to build the part of the line that is in its service territory. CP's part of the line, approximately 60 miles long, will provide approximately 500 MW of interconnection capacity to the system at a cost of 79 M\$ (in 1994\$), including the cost of a new substation at Branch in South-Central Michigan (Johnson 1992). The initial proposal is for a single-circuit line built on towers that can support a second circuit. The double-circuit construction costs are about 13 M\$ more than single-circuit construction (Johnson 1992).

The Branch substation will accommodate phase-shifting transformers and a 345 kV to 138 kV step-down transformer and 138 kV construction to supply local load in the Branch area. The transformers and circuit-breakers at the Branch substation will cost approximately 27 M\$, with about 5 M\$ of that for the 345 kV to 138 kV transformer and 138 kV construction and the rest for the phase-shifting transformers. The capacity of the line (*cf.* Examples 6 and 7 in Chapter 2) is limited by the rating of the phase-shifting transformers, which are necessitated by phase-

angle differences between the Michigan and Indiana systems.

The CP-PSI line has become entangled with other CP activities. In 1968, CP began planning the Midland nuclear power station, located in Midland County, Michigan. The original design included supply of waste steam to the adjacent facilities of the Dow Chemical Company (Dow). However, by the early 1980's, financing problems caused CP to halt construction. As of July 1984, \$4 billion had been spent in bringing the plant to 85% completion.

Subsequently, CP decided to convert the Midland Station into a natural gas-fired combined cycle facility, the Midland Cogeneration Venture (MCV). The design feature of supplying steam to Dow was kept, allowing the new facility to be a qualifying facility (QF) under PURPA. Approximately \$1.5 billion of assets, including the two steam turbine generators, piping, buildings, transmission tower, and control room were useful

in the new facility; however, \$2.2 billion of nuclear equipment was unusable and abandoned. The cost of the abandoned equipment was written down by CP (MCVLP 1991).

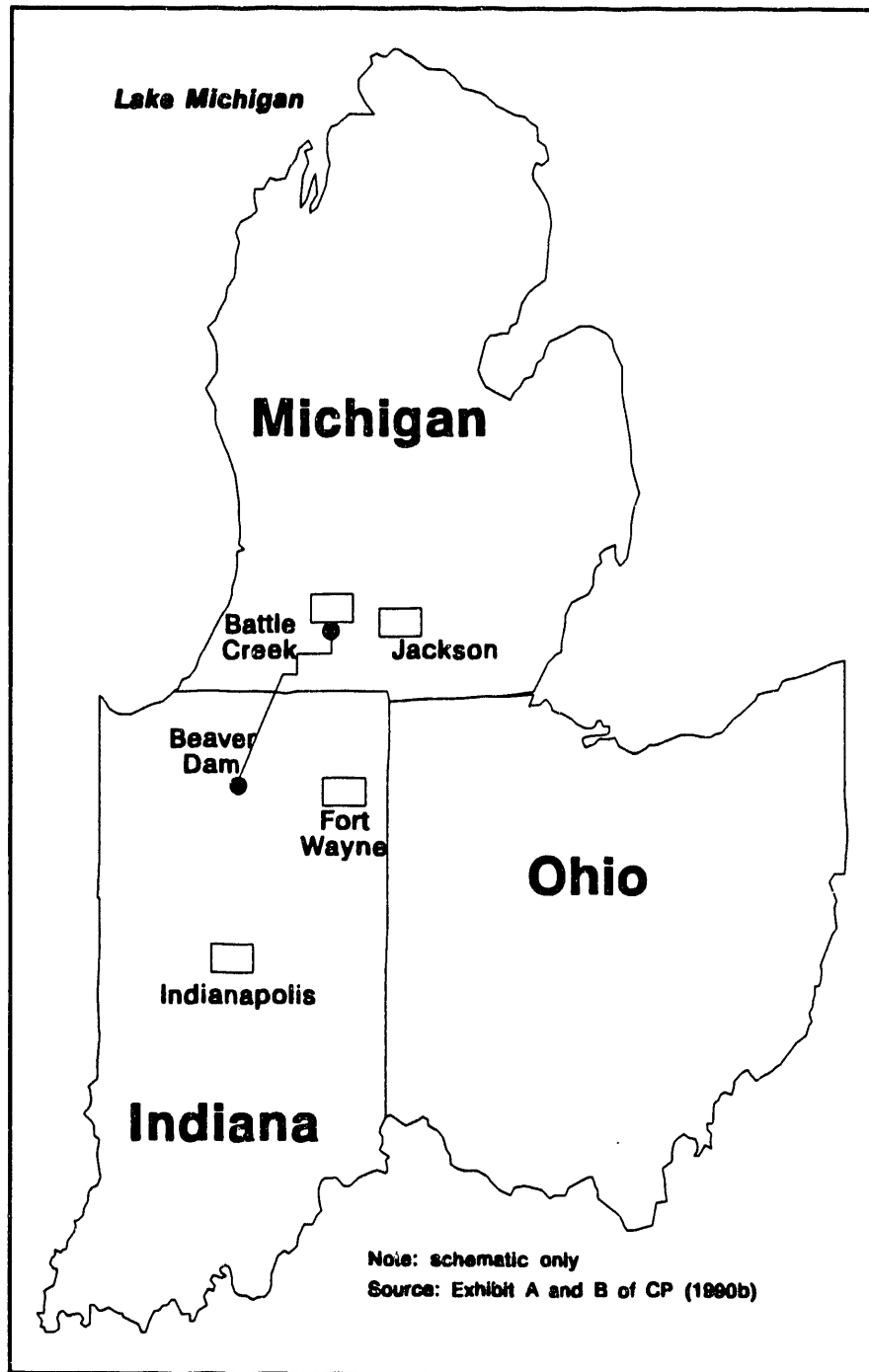

**Figure 4-5**  
**Schematic Map of CP-PSI Line**



The MCV is partly owned by a subsidiary of CP's parent company, CMS Energy. MCV began generation in 1990 and has contracts for sales of energy and capacity to CP under its Power Purchase Agreement (PPA); however, the contracts are subject to judicial and administrative rulings at the Michigan Public Service Commission (MPSC) involving the business relationship of MCV and CP (MCVLP 1991).

There is some question of whether MCV will be able to sell its full capacity of approximately 1400 MW to CP, since the MPSC ordered in 1989 that CP could not purchase more than 870 MW of capacity from projects of any single fuel type (MCVLP 1991). CP has contracts for 30 MW of capacity from another gas-fired facility, allowing 840 MW to be purchased from the MCV. The MPSC orders were appealed and are subject to ongoing dispute. However, CP is contractually obliged to pay for the capacity over a 35 year period: if CP cannot purchase or resell the MCV power, then "Consumers could incur estimated after-tax losses related to this issue of up to \$13 million in 1992, \$35 million in 1993, \$55 million in 1994 and \$76 million per year beginning in 1995 over the PPA's remaining 35 year term" (CP 1992b). The total losses are far in excess of the cost of the CP-PSI line itself.

MCV has approached CP for estimates of the cost of transmission service to *deliver* power to PSI's service territory to facilitate MCV participation in PSI's non-utility resource bidding program. CP responded with estimates of transmission costs for incremental facilities needed to support sales of MCV capacity and energy to PSI. The cost estimates were based on the assumption that the CP-PSI line is already in place and include the possibility that MCV may be simultaneously wheeling over the line to PSI while CP is purchasing power from PSI (CP 1990a).

In addition to MCV, other alternative resources have been considered in this case. One of these was an offer from an association of MUNIs (MPPA, 1991). CP called into question the validity of this offer (CP 1992c). Wheeling arrangements for the delivery of economy energy were also examined.

#### **4.6.2 Significant Issues**

The line illustrates two types of economies of scope of transmission operation:

1. the tapping of the line at Branch to support the local 138 kV system as well as the line being a bulk transmission path from CP to PSI, and
2. the potential for wheeling MCV power over the CP-PSI line to PSI while CP is simultaneously buying power from PSI over the same line.

We will discuss these economies of scope in the following paragraphs.

CP argues that the line is justified on the joint basis of the need for construction to Branch to support the 138 kV system and the benefits of economy energy purchases from PSI.

Construction at Branch would have been eventually required even without the CP-PSI line because of voltage problems in the area. However, for the scenarios analyzed in most depth in CP's Application to the MPSC (scenarios B1R, B2R, and B3R in (Osborn 1992)), the complete project is only marginally financially viable even including 25 M\$ of benefits due to economies of scope in supporting the 138 kV system at Branch.

Like the DPV2 case, there was substantial dispute about the data used in the economic analysis. Several new economic issues emerged during the litigation (costs of Clean Air Act compliance and potential cost settlements to account for parallel flows on the interstate transmission network). These issues were not incorporated into the economic analysis. Both the MPSC staff and CP asserted that their differing positions were consistent with the last IRP. Yet each party found some reason to either update or deviate from it in their analysis.

The opponents of the CP-PSI line argue that the real purpose of the line is to support MCV (Shaffer et al. 1992). Since potential MCV transactions are North-to-South, while CP argues that the main purpose of the connection to PSI is for South-to-North economy purchases, it is reasonable to think of potential MCV transactions as counterflow wheeling. In Section 5.4 we will see a case where tariffs for counter-flow wheeling service include charges for losses and capacity, even though counter-flow wheeling reduces losses and loading. This seems to be the usual practice in the provision of transmission services.

The line is the most expensive, on a dollar per kilowatt-mile basis, of the lines we have examined. Even excluding the cost of the phase-shifters; the 345 kV to 138 kV transformer; the 138 kV construction; and, the cost difference between single-circuit and double-circuit construction, the line costs 1.24 \$/(kW.mile). CP has argued that there are intangible benefits of the line, particularly the increased competitive pressure that it will create. The MPSC staff has shown skepticism about these (MPSC, 1992).

Finally, while the CP-PSI line is physically a single transmission line, the parts of it in Michigan and Indiana are being certified separately by the Michigan and Indiana PUCs, respectively. There is apparently no cooperation between the Michigan and Indiana Commissions to ensure that the assumptions presented to each are consistent. For example, the most favorable economic scenarios presented by CP for the CP-PSI line depend on the availability of particular capacity contracts from PSI (FS-1 capacity); however, there is no independent documentation from PSI or the Indiana Commission presented in the CP Application that such capacity will be available. As in California, there do not seem to be any clear standards for assessing the benefits of a line.

### **4.6.3 Summary**

The significant institutional issues are: the asymmetric constraints on CP and the MCV, which may motivate the construction of a line to allow the MCV to sell its output; potential state versus regional conflicts, since the line spans from one state to another yet is being analyzed in a piecemeal fashion; pecuniary and real benefits, since the line may have been proposed essentially to transfer cost responsibilities; and, standards in the assessment of need for a transmission line.

The main technological issues are: the negative network externalities that necessitate phase-shifters to enhance transfer capacity, and economies of scope in transmission operation. The optimality of the project is at question, both operationally and planning.

### **4.7 Synopsis**

The DPV2, COTP, and K-V case studies reveal that the technical complexity of evaluating the benefits of the lines overwhelms the regulatory process. In DPV2, the changing economics of the project presented at the CPUC cast doubts on the transmission planning methodology used by its proponent. In COTP, an economic benefit analysis is used by the IOUs to justify participation in the project, while the more fundamental reasons may be competition between transmission owners and transmission dependent utilities. In K-V, the allocation of costs turns on ill-defined assessments of system benefits. Collectively, it is apparent that the regulatory apparatus is unable to perform adequate technical evaluation.

While it might be hoped that each of these three proposals is based on a careful cost/benefit analysis of alternatives by its proposer, it seems more likely that the analyses presented to the CPUC are justifications for the projects developed *after* the respective utilities decided to become involved. This is particularly obvious in the DPV2 case. Economic and technical justifications are advanced for projects that owe their existence more to institutional and political motives, with technical complexity obscuring the institutional motives. This is apparent in the CP-PSI line.

A subsidiary issue is that time and resources are wasted on discussing and refuting *ad hoc* studies. Standardized definitions of benefits and uniform software tools would make such studies much more straightforward. The joint study conducted for DPV2 is an important step in this direction.

The COTP indicates that the piecemeal jurisdiction of State regulation is unable to effectively regulate large regional projects; however, neither has the FERC been able to encourage regional views of transmission expansion. Recently, two Bills, Tauzin (1991) and Markey (1991), have been introduced in the House of Representatives to increase transmission access. These Bills may increase the power of the FERC in transmission (Morris and Dozier 1991).

The fourth case study, the DL/GPU joint venture, is an example of a project that serves both a specific need, but to take advantage of economies of scale, it is overbuilt relative to minimum requirements. One third of its capacity will not be ratebased. Although the Pennsylvania PUC should be concerned with the ratebased part of the project, the shifting of risk from ratepayers to shareholders represents a strong commitment on Duquesne's part to the viability of the project.

**Table 4-5  
Case Studies and Issues**

Category	Issue	Features	DPV	COT	K-V	DGP	CPP
Institutional	Competition	Wheeling Access for TDUs (transmission dependent utilities)	X	X			
		Independent Power			X		
	Regulation	Asymmetric Constraints		X		X	X
		State and Regional Conflicts		X			X
		Pecuniary versus Real Benefits	X	X			X
	Information	Asymmetries	X		X	X	
	Standards		X	X	X		X
Technology	Line Characteristics	Radial	X	X	X	X	
		Network		X	X	X	
	Network	Negative	X	X		X	X
		Positive	X		X	X	
	Externalities	Synergies	X			X	
	Structure of Scale	Intertemporal Allocation	X		X		
		Growth Uncertainties			X	X	
		Unsustainability		X			
	Economies of	Scope	X		X		X
	Decision-Making Complexity	Feasibility versus	Operations	X	X		X
Planning			X	X	X	X	X
Optimality		Operations and Planning	X	X			X

**Key:** DPV Devers-Palo Verde 2  
COT California-Oregon Transmission Project  
K-V Kramer-Victor Upgrades  
DGP Duquesne Light/GPU Joint Venture  
CPP Consumers Power-PSI Line

On the other hand, the last case study, the CP-PSI Line, is particularly troubling since a line is potentially being built to circumvent a MPSC ruling. Furthermore, if CP is successful, then the ratepayers of Michigan will pay for the line.

The case studies and issues are summarized in Table 4-5. The detail of treatment of issues for certification of lines should be compared to the limited detail considered in the Integrated Resource Plans discussed in Chapter 3. Several institutional issues such as competition and the need for standards are prominent in most of the case studies, but are not necessarily being addressed in the regulatory process. Technological issues such as economies of scale of construction and externalities due to parallel flow are also common to most of the studies.

While we do not necessarily believe that these projects are typical of construction projects in the United States as a whole, the fact that they represent over a billion dollars in investment suggests that the issues they raise should be treated coherently in transmission planning and access proposals, and considered in the design of standards. In the next chapter, we will investigate whether or not current proposals address these issues.

## **Chapter 5**

# **Survey of Selected Transmission Policies at the Utility, State, and Federal Levels**

### **5.1 Overview**

In this chapter we examine a number of transmission policies that provide guidance on improving the regulatory treatment of the transmission issues developed in the previous chapters. The goal of this chapter is to examine adopted or proposed mechanisms that address regulatory problems in some unique fashion. Our choices are eclectic and not comprehensive, but they are designed to outline the scope of possible options. We first briefly review four utility proposals and frameworks:

1. the Vermont Electric Transmission Company;
2. the Western Systems Power Pool Experiment;
3. the Large Public Power Council Proposal; and,
4. Pacific Gas & Electric's Multi-Attribute Bidding framework.

The first and second have been implemented in Vermont and across 22 Western States, respectively, while the third and fourth are still under discussion. Many of the issues in the last three proposals are under negotiation or subject to change. Any criticism we have of them, therefore, should be viewed in that context and not taken as reasons to reject the proposals outright.

At the state level, we review in Section 5.3:

1. the Public Service Commission of Wisconsin 'Advance Plan' (WAP) process, and,
2. the California Public Utility Commission's (CPUC's) Rules for Access to Computer Models.

The WAP process has been in force in Wisconsin since 1975 and will be reviewed in greater depth than the utility proposals and the CPUC Access Rules.

Finally, in Section 5.4, we consider the following Federally adjudicated cases:

1. PG&E's Stanislaus Commitments;
2. Toledo Edison and Cleveland Electric nuclear plant license conditions; and,
3. Utah Power and Light-PacifiCorp Merger Implementation.

While these three cases are not generic proposals, they represent potential directions for Federal policy.

Although the utility proposals and frameworks, State legislation, and Federal cases may seem to be disparate areas for study, the division of authority between the State and Federal government necessitates complementary action at the State and Federal level to mesh with the institutional arrangements of utilities (Stalon 1991b). For this reason, we bring these initiatives together in this chapter.

In the last subsection of each study we will summarize the main issues treated coherently by the initiative. Then, in Section 5.5, we tabulate the summaries and discuss the potential for complementary combinations of cases to simultaneously address all of the issues raised in Chapter 2.

## **5.2 Utility Proposals and Frameworks**

### **5.2.1 The Vermont Electric Transmission Company (VELCO) Description**

VELCO was formed in the mid-1950s when utilities in Vermont had the opportunity to acquire contracts for power from United States Government financed hydroelectric projects in the St. Lawrence Seaway (VELCO 1989). Access to this power necessitated coordinated transmission construction. In 1956, an IOU, Central Vermont Public Service Corporation, proposed the formation of VELCO to construct, finance, own, and operate new transmission facilities. Subsequently, other Vermont utilities joined in sponsorship and VELCO was formed in 1956, owned at its inception by (VELCO 1957):

- 4 Cooperatives;
- 15 Municipal Utilities; and,
- 14 Investor-Owned Utilities.

VELCO obtained ownership of the bulk transmission system in Vermont and took responsibility for transmission planning. Its function is: "to contract for the purchase of...energy and its resale, on a non-profit basis, without preference or discrimination to electric distribution companies, cooperative, municipal, and privately owned, for distribution within the state" (VELCO 1957). VELCO has undertaken long-term transmission planning, with consideration given to multiple power supply scenarios and ranges of estimated growth rates, and multiple transmission, transformer, and capacitor expansion alternatives (VELCO 1987). Because VELCO is not owned by any individual utility, and is not run to profit from transmission services, the strategic aspects of information asymmetry are defused since there is no incentive to conceal or misrepresent transmission system data.

Under the VELCO agreements, transmission services can be reassigned (VELCO 1981), and disagreements are to be submitted to binding arbitration. These arrangements have been in place for more than thirty years and have successfully coordinated the transmission needs of IOUs, MUNIs, and Cooperatives in Vermont. While the amount of transmission owned by VELCO—less than 500 miles of line—is small, the longevity of VELCO indicates that the



institutional issues of multiple ownership can be handled within a conventional company structure.

### ***Summary***

The institutional issue of wheeling access has been treated coherently by VELCO, and the single transmission company treats all utilities in Vermont symmetrically, considering real benefits of transmission access. By having only one transmission company to deal with, transmission access has been standardized; however, state and regional conflicts are not addressed explicitly. The company arrangement defuses the problem of information asymmetries. By performing statewide planning, the technology structure issues of radial and network expansion, intra-state externalities, and economies of scale and scope are treated coherently. Long-range planning is addressed. The potential for unsustainability is avoided by having only one authority to undertake transmission construction.

## **5.2.2 Western Systems Power Pool (WSPP)**

### ***Description***

The WSPP began in 1987 with 15 members, and has grown to 38 members in 22 States and 1 Canadian Province (Gross 1991). Its operation between 1987 and mid-1991 was as a FERC-approved experiment in flexible pricing. Utilities participated in coordination sales to improve economic efficiency at prices decided between participants, but subject to FERC ceilings. Each transaction is voluntary. It is unlike traditional power pools in that there are no provisions to increase reliability, no central economic dispatch, no centralized planning, and no guarantees of transmission access (FERC 1991a). Wheeling services and energy can be bought and sold between participants and, as well, energy exchanges can take place; that is, power is exported from one utility to another at one time and is 'paid back' at some other time, based on an agreed rate of exchange.

In 1991, the WSPP became permanent, with FERC imposing lower ceilings on prices than were in force during the experiment (FERC 1991a). Currently, there is considerable controversy about whether or not the WSPP will continue and we will not discuss many important provisions that have been mooted by the FERC decision.<sup>16</sup> Our analysis will therefore be deliberately incomplete and instead we will concentrate on three particular aspects of the WSPP that have universal applicability:

1. efficiency improvements through trade;

---

<sup>16</sup> In particular, we will not discuss in detail the long-term access provisions that were in Appendix C of the January 2, 1991 filing for permanent continuation of the WSPP agreement (WSPP 1991).

2. the balance of short- and long-term issues; and,
3. standards.

One aspect of the WSPP proposed agreement, binding arbitration, is also a cornerstone of the Large Public Power Council proposal and will be discussed in Subsection 5.2.3.

First, consider the efficiency aspects of voluntary transactions at flexible prices. Since every such transaction is entered into voluntarily at mutually agreed prices, it is essentially tautological to observe that operational efficiency is improved, assuming that only negligible negative externalities are imposed on third parties.

A more subtle question is whether *every* potentially efficiency improving transaction actually takes place. This question is more difficult to answer because it is counterfactual. However, certain transmission-dependent utilities, such as the Sacramento Municipal Utility District, argue that pricing of transmission services under the WSPP has precluded "access to power alternatives which were otherwise available and economical" (Schori 1991). In setting the permanent WSPP arrangements, the FERC has apparently tried to ensure access by imposing ceilings on the prices of wheeling and energy sales transactions and a ceiling on the ratio for energy exchanges; however, the WSPP argues that this will simply stop transmission service from being offered, not reduce its price (Gross 1991).

A different approach to ensuring access is to foster long-term competition in transmission supply by allowing participation and ownership in transmission with resale rights at market-based prices. Provisions along these lines, including cost-based long-term access and a secondary transmission market, were part of the filing for the permanent WSPP (WSPP 1991), but were deemed inadequate by FERC and subsequently deleted from the WSPP agreement by WSPP and some member utilities (FERC 1991b). The member utilities of WSPP are not apparently prepared to undertake long-term construction unless they can set short-term transmission prices at market rates. This course of events illustrates that there is a balance between short-and long-term access to existing transmission and long-term construction, but shows that solutions can be difficult to find. The January 2, 1991 filing of the WSPP proposal explicitly considered the trade-off between these issues.

The third issue is the standardization of transmission transactions that is afforded by the WSPP agreement. An uniform umbrella contract was cited by system operators as important in 90% of the traded volume attributed to WSPP transactions during a two year test period (FERC 1991a). Information is exchanged through an electronic bulletin board at the 'hub' that acts as an 'information clearinghouse' (Gross 1991), with sellers posting offers to sell, and buyers posting offers to buy.

Although transmission availability was important for many WSPP transactions, two-thirds of the trade did not involve wheeling. The WSPP's most important contribution to increased trade may be through standardization of contractual and communication procedures. For example, the

FERC Staff assessment attributes most of the trade gains to the umbrella contract and to the 'hub' arrangement (FERC 1991a).

### ***Summary***

As noted above, we have omitted analysis of many aspects of the WSPP in this very brief discussion because the agreement is subject to ongoing litigation and changes. Two issues that appear to be important are the interplay of operations and planning, and standardization. The balance of short-term access at flexible prices and long-term access at cost-based prices in the WSPP January 2 filing was an attempt to reconcile these operational and planning issues. Perhaps more significantly, the use of an umbrella contract and uniform communication indicates the importance of the institutional issue of standardization.

### **5.2.3 Large Public Power Council (LPPC)**

#### ***Description***

There are currently several transmission proposals advocated by interest groups such as MUNIs. They are discussed and evaluated in the Transmission Task Force Report (FERC 1989). One of these proposals, by the Large Public Power Council (LPPC), which consists of seventeen of the largest public utilities in the United States, advocates the formation of an 'Association for Transmission Service' (LPPC 1990). LPPC proposes "a *voluntary* system for increased access supported by a member commitment to binding arbitration" (Schori 1991). The principles of the Association would be implemented contractually, with members obligated to maintain membership for some minimum period after any unfavorable decision.

Advocacy of binding arbitration is unusual in industry proposals and has the advantage of decreasing the role of litigation at State PUCs and FERC. In exchange for decreased control over transmission, transmission owners would obtain the advantages of more flexible pricing and arbitration by technical experts. As noted above, similar arbitration arrangements were part of the VELCO arrangements and the WSPP filing (WSPP 1991).

Two major purposes of the proposed Association are:

1. the development of "common principles for determining...excess transmission capacity" (LPPC 1990), and,
2. dissemination of general information to facilitate analysis of transmission issues.

These purposes would significantly help standardization of transmission analysis. The Association would require "members to make their excess transmission available for firm and non-firm wheeling" (LPPC 1990), while encouraging joint ownership of transmission facilities to facilitate multi-party access.

The proposed arbitration process allows the issues to be discussed; however, it is not clear that this setting would solve the problems of information asymmetry, except to the extent that the greater publicly disclosed 'general information' would force utility positions to be at least internally consistent. It is unlikely that transmission owners will be willing to disclose their 'excess capacity,' particularly given their pecuniary interest in limiting transmission access, so that the inevitable information asymmetries may make these purposes difficult to achieve. The proposal is commendable, however, in focusing on the issue of excess capacity.

LPPC advocates competitive pricing where a transmission market exists, and cost-based pricing otherwise (LPPC 1990). However, a competitive transmission market seems improbable without joint ownership or a secondary transmission services market, so that in the short term, the promise of 'competitive pricing' may be an empty slogan. For example, the Sacramento Municipal Utility District's interpretation of LPPC's pricing proposal is that purchasing utilities would pay embedded costs plus reinforcement costs (Schori 1991). Nevertheless, the Association would provide "a forum and mechanism to resolve parallel flow issues" (LPPC 1990), therefore addressing network externalities. It also encourages economic efficiency.

### *Summary*

The LPPC proposal addresses the institutional issue of information asymmetries through an arbitration process and encourages the adoption of standards for the calculation of excess capacity. Arbitration may also reduce some of the costs of rent-seeking activities by parties competing for transmission access. As regards technological issues, with the exception of negative externalities of parallel flow, the proposal only indirectly addresses them to the extent that the 'technical experts' and protagonists choose to raise them during arbitration.

## **5.2.4 Pacific Gas and Electric's Multi-Attribute Bidding Framework**

### *Description*

Pacific Gas and Electric (PG&E) has designed a framework for evaluating the costs and benefits of bids submitted to a vertically-integrated utility-sponsored auction for generation resource acquisition (Shirmohammadi and Thomas 1991). The framework incorporates the technological characteristics of proposed generation projects and considers the cost of transmission access. The goal of this integrated resource acquisition framework is to ensure that winners of the auction comprise elements of a least-cost construction plan for the utility.

Bidders are provided with a set of geographically and temporally disaggregated prices that represent estimates of the marginal costs and benefits of generation by independent power producers at each bus in the PG&E system, including components for transmission cost estimates calculated using the LOCATION program (see Section 6.4). Making such information available allows bidders to tailor their bids to utility needs. The framework is 'transparent' in that bidders

are appraised of the utility decision-making process before making a bid and are provided with estimates of transmission and other costs calculated for each bus.

The LOCATION program estimates the transmission costs to support incremental generation additions through a sensitivity analysis of the solution to an 'optimal power flow' (OPF) performed on a 'base-case' system. As we will discuss in Section 6.4, all line expansions are treated as radial.

Winners of the auction are paid their bid price for generation, while all necessary transmission expansion past the point of generator inter-connection is to be undertaken and paid for by PG&E. PG&E is therefore proposing to 'internalize' the costs and benefits of transmission as far as possible, including the economies of scale in construction. To the extent that the utility is motivated to maximize efficiency, the utility will also be motivated to make the correct transmission decisions. The bidding process allows the utility to select the most economic generation based on:

1. the net benefits of the chosen supply bids, minus,
2. the total system transmission reinforcement costs required for interconnection as estimated by LOCATION.

PG&E plans to stand by the transmission cost estimates provided in the bidding information up to a pre-announced limit on additional generation at each sub-station (PG&E 1991b). While bidders might question whether the transmission cost estimates are reasonable, in the absence of collusion there is no incentive for the utility to misrepresent the true costs of transmission since the utility itself pays for transmission upgrades necessary for expansion. In other words, the issue of information asymmetry between utility and bidder is defused by the bidding framework. This is in strong contrast to the case where transmission costs are litigated after the signing of contracts, as in Kramer-Victor, where the utility stands to gain by strategic misrepresentation of costs and benefits.

Even if strategic issues are defused, however, economies of scale pose a problem for any incremental approach. Recall that in Kramer-Victor, economies of scale of transmission construction made the connection costs of Luz and Cal Energy cheaper than the sum of radial connection costs. Although PG&E plans to undertake detailed transmission planning once the winning bids are known, this will not be reflected in the bidding scheme, and the timing of utility auctions may make it difficult to plan to take advantage of economies of scale. We discuss this in Appendix A.5.

While the incremental framework leads to suboptimal estimates of transmission expansion costs, the authors argue that: "[i]n practice, however, this sub-optimality impact is mitigated by the size of anticipated capacity additions relative to the large size of California utility systems" (Staschus et al. 1991a). Small generation projects would fall into this category. The transmission benefits of demand-side management projects could also be accurately estimated.

Although bids in PG&E auctions may be geographically dispersed throughout its service region in California, the Kramer-Victor case shows that in the neighboring Southern California Edison (SCE) system independent producers can provide a locally very large increment to the system that necessitates the construction of a major transmission line. The potential for such additions on systems such as SCE's may limit the applicability of PG&E's framework.

Even if each addition is relatively small, planning more than a few years into the future presents problems in the definition of the base-case for the OPF since the base-case is used to estimate the incremental cost of transmission in the future system. The base-case must be based on either:

1. current generation, transmission, and demand conditions, or,
2. estimates of future conditions.

With the first approach, the sensitivity analysis will not necessarily reflect future sensitivities. The second approach assumes some of the parameters that are being derived from the sensitivity analysis. For example, with the second approach, the base-case may include some generic future generation and transmission proxy to satisfy future demand conditions. Different choices of proxy expansion may produce very different winners in the bidding process. Suppose that the base-case transmission proxy has ample transmission for potential suppliers North of PG&E, but is constrained to the South. Then bidders in the South will face higher transmission costs, even though the transmission proxy is not a sunk cost at the time of the bids. Since the goal is an optimal investment plan, the reliance on assumptions about future generation and transmission, as required by the OPF, is questionable.

In contrast, if *existing* generation and transmission can support the solution of the OPF for a future demand scenario, then the framework may prove very successful. In particular, if a regional transmission system has ample capacity, then the framework provides a good way to evaluate the optimal mix of generation capacity additions. The framework could even be used for wheeling transactions, although it is not intended for this purpose, PG&E argues, because of risk allocation issues (PG&E 1991b).

For the existing transmission to support future generation additions, we must posit that the transmission system is continually overbuilt, somewhat independently of the guidance given by the LOCATION program itself. Given the lumpiness and economies of scale of transmission, this may not yield a significantly worse transmission plan than with central planning under complete prior knowledge of bidders' characteristics: the advantages of a transparent bidding scheme would then strongly favor the PG&E framework.

## *Summary*

PG&E's bidding framework treats many institutional issues coherently. It treats access to transmission by independent power producers, but does not currently incorporate wheeling. The transparent bidding process is much fairer to bidders than a process that allocates transmission costs after contracts are signed, because information asymmetries over transmission cannot be used to discriminate against independent power. The framework is a logical approach to standardizing resource acquisition and evaluating the real costs and benefits of independent power, including the effects on transmission.

Technological issues, such as economies of scope and externalities of operation are treated coherently, but economies of scale and network expansion cannot be treated because of the incremental framework. All expansion is treated as radial so that true network planning is not performed. By internalizing the cost of transmission in the bidding process, PG&E can evaluate the true benefits and costs of generation and optimize the mix of generation and transmission additions.

## **5.3 State Legislation**

### **5.3.1 Wisconsin Advance Plan (WAP)**

#### *Description*

The State of Wisconsin has regulated utilities since 1907 and is relatively unusual amongst US States in that it regulates MUNIs and has planning authority over cooperatives (Munts 1991). It was the first State, in 1975, to mandate long range utility planning, establishing the 'Advance Plan' process to: "inform the Public Service Commission of Wisconsin (PSCW) and the general public of state electric utilities' plans to meet their customers' energy needs" (PSCW 1991a). New long-range plans are developed approximately every three years. Although the first plans focussed on supply-side problems, they have evolved into an integrated planning process that includes demand-side management and transmission planning (Munts 1991).

The PSCW intends that the Wisconsin and surrounding electrical transmission systems be investigated in Advance Plans "on a single-system basis with the objective of identifying problems and solutions, irrespective of transmission system facilities' ownership" (PSCW 1991a), recognizing the "impacts on parties not directly involved in [transmission] transactions" (PSCW 1991a).

The PSCW also intends that transmission planning be based on a 15-year planning horizon considering "the costs of alternatives, using consistent facility costs and including consideration of losses" (PSCW 1991a), with routes and alternatives made public well in advance of final decisions. This long-range planning is intended to include "examining the effect of higher and lower growth rates than the assumed growth rate" (PSCW 1991a).

The Advance Plan process encourages a uniform objective with the consideration of real instead of pecuniary benefits, considers network externalities, the effect of growth uncertainties, and requires some attempt at optimizing a long term-plan for transmission. In Advance Plan 3 and Advance Plan 4 the PSCW ordered the utilities to follow a specified set of transmission planning criteria to ensure that there is adequate substantiation of the transmission plans (Army and Dasho 1988). These criteria lay out an information based approach that allows input by PSCW staff and intervenors.

Transmission owning utilities in Wisconsin were ordered in Advance Plan 5 (AP5) to:

- adhere to twenty principles of joint use and cost sharing in developing joint use and cost sharing transmission agreements with each utility, and,
- file wheeling tariffs with FERC (PSCW 1991a).

Subsequently, all the Wisconsin IOUs submitted transmission service rate schedules to FERC, with varying levels of disagreement over conditions and prices of transmission service. Several Wisconsin utilities, including Northern States Power (NSP), Wisconsin Electric Power (WEP), Wisconsin Power and Light (WPL), Wisconsin Public Service (WPS), and Dairyland Power Cooperative (DPC), have challenged the Public Service Commission of Wisconsin's (PSCW's) joint use and cost sharing principles in state court (PSCW 1991a). All but one of the tariffs were accepted by settlements. The NSP tariff case proceeded to trial and is still under consideration by the FERC. The WPL and Madison Gas and Electric (MGE) tariffs are particularly interesting models because they are streamlined and easy to use (Army and James 1991).

In the most recent Advance Plan, number 6 (AP6), the utilities were required to jointly plan their generation, transmission, and demand-side options. Although the PSCW issues papers to promote discussion on particular questions such as externalities (PSCW 1991b), the Plan does not specify in detail the methods of planning. Instead, the individual utilities are expected to agree amongst themselves on externality methodologies. The joint plans are then subject to review by the PSCW. The PSCW relies on the discipline of the competing interests of utilities and staff review to validate analysis.

In transmission, geographically adjacent utilities cooperated in planning transmission expansion while the Wisconsin state-wide transmission limits on East-West transfer were jointly examined in an 'interface study' (PSCW 1991a). In addition, a 'bulletin board' was established so that utilities could exchange information about generation and demand-side options. We will first describe the bulletin board, which does not currently explicitly consider transmission, and then discuss the interface study, which integrates transmission, supply, and demand options.

The bulletin board process begins with a forecast of demand. Individual utilities develop demand-side and generation plans, selecting the most economic resources from a range of options. Options that are not included in individual utility resource plans are then posted on the bulletin board and information on individual utility needs for base load resources is also shared. "The utilities then negotiate to determine the Bulletin Board options to include in the AP6 Joint



Plan” (PSCW 1991a), including demand-side options and short-term exchanges. The effects of this coordination on baseload supply additions and demand forecasts are then incorporated into the Joint Plan.

As it stands currently, the bulletin board process explicitly assumes “that adequate transmission facilities will exist to enable parties to share resources” (PSCW 1991a), so that transmission planning is not integrated with generation and demand-side planning. If transmission constraints are not binding, then this is an adequate approach, particularly for demand-side options. Any transmission constraints identified would be addressed in the transmission plan development.

Transmission is constrained between the East and West of Wisconsin. The ‘interface study’ (PSCW 1991a) is a response to these constraints that applies the Advanced Plan principles of long-term integrated planning. As part of the study, the Wisconsin utilities were directed to determine the costs and benefits of increased transmission capacity. The utilities also investigated the costs of expanding transmission access options at varying voltages and along various routes including both AC transmission options at 115, 161, 230, and 345 kV and DC options at  $\pm 250$  kV (PSCW 1991a). The routes of the lines associated with representative alternative proposals are shown in Figure 5-1. Seven alternatives, labeled 1, 2, 3, 4, 5B, 6, and 7B-3 are shown in the figure. The lines are in the service territories of several Wisconsin utilities and extend slightly outside of Wisconsin. Analysis of the options was carried out using two analytical tools: a full AC powerflow model of the generation and transmission system and a multi-area hourly production cost simulation program. In both cases the data representation included facilities in a large portion of the central United States (Army 1992). Since the options include multiple combinations of varying voltage and capacity options, economies of scale in

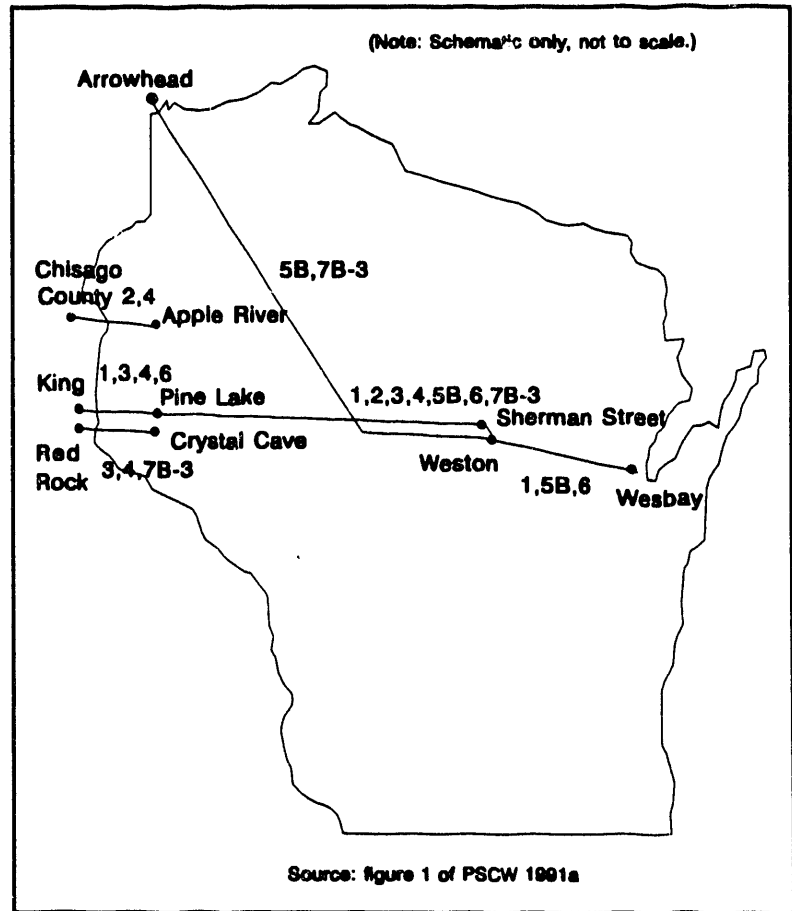

**Figure 5-1  
Potential Routes for Transmission  
Expansion in Wisconsin**

transmission construction and synergies are addressed; however, economies of scope of operations were not apparently considered, primarily because limits on transfer capacity across the interface occur only in the West to East direction due to regional resource balance (PSCW 1991a).

The comprehensiveness of these options and the explicit comparison of benefits of access and costs of transmission alternatives represents a thorough effort to optimize transmission expansion over the long term as part of an integrated resource plan. The consideration of geographically dispersed alternative routes at varying voltages to solve a set of transmission problems indicates that true network planning is taking place, and not only planning of radial reinforcement. Several of the options were identified in Advance Plan 6 as deserving of continued study (PSCW 1991a); however, as of the filing of AP6 in March 1991, none of the proposals have progressed past the initial planning stage. The Advance Plan process allows ample time to modify plans, in the light of new or changing needs, before a utility is committed to construction.

In principle, the transmission needs of IPPs can also be integrated into the plan; however, IPPs have not featured prominently in the Advance Plan Process. As in the case of Kramer-Victor, the unanticipated transmission needs of IPPs and QFs may not be well integrated into long-term planning. It is not clear how IPPs, that might bid to meet capacity needs, will get information about transmission costs for specific sites. Once IPPs have developed projects sufficiently to bid for an acquire contracts, the transmission expansion plan will have to be re-optimized in a way that may be more expensive than if site information had been known in advance. Wisconsin has had less experience with IPPs than other states. It is just beginning to deal with these issues. Whether planning co-ordination becomes a problem remains to be seen.

Information asymmetry may limit the veracity of study results. For example, none of the estimates of increased transmission capacity benefits in the interface study were tied to any obligation to buy or construct transmission capacity, so that, in principle, there was no obligation on utilities to reveal truthfully their needs for capacity. The ability of the PSCW to specify how the benefits of increasing transfer capability would be determined and to audit and verify engineering-economic studies were the regulatory disciplining forces available to the PSCW to ensure that the Wisconsin utilities revealed their true benefits of increased transmission capacity. This feature appears to be generic to the 'Advance Plan' study, so that good planning depends on truthful revelation by the Wisconsin utilities, induced by analysis, auditing or verification activities of PSCW staff, intervenors or other utilities.

We have argued in the case studies in Chapter 4 that coherent analysis of information asymmetries is essential. It is necessary to either provide incentives for truthful revelation, or accept the consequences of information asymmetries. Since the Wisconsin utilities are each relatively small compared to the total Wisconsin market, it may be possible to assert that competition disciplines their responses. For example, each utility may be prepared to provide accurate data for loadflow analysis since nearby competitors already possess this data and can verify it. In the area of Demand-Side Management, such yardstick competition has been used to assess utility performances (Kahn and Goldman 1991).

A significant feature of the joint planning approach is that duplication of transmission can be avoided. The issue of unsustainability is therefore addressed. If, as suggested in Army and James (1990), third-party access can at the same time be assured by the PSCW, then this is a significant advantage; however, if access can be denied by transmission owners, then preventing duplication forecloses the option of over-building transmission to assure competition in the much more valuable generation market. We have observed that assuring such competition is apparently a major aspect of the California-Oregon Transmission Project (COTP). Joint ownership may mitigate this problem and the PSCW advocates that the "equitable approach to allowing smaller utilities access to low-cost power sources is to allow them to share in the use and costs of the existing transmission system and any needed additions" (PSCW 1991a).

The PSCW is encouraging a single statewide agreement on transmission access, while proceeding initially with a "gradual approach" (PSCW 1991a). The Advance Plan process has the potential to standardize transmission access for utilities.

### *Summary*

The WAP coherently treats the institutional issues of utility and independent power access to transmission through joint planning and ownership of transmission. IPP access, however, has not played a prominent role to date. While IPPs are free to participate in transmission planning studies, this has not occurred to date. The regulatory arrangements in Wisconsin prevent asymmetric constraints on utility industry participants. The PSCW has explicitly set standards and required joint planning. The PSCW focuses on real rather than pecuniary benefits.

Information asymmetries are partially addressed through the discipline of joint planning; however, the resolution of information asymmetries depends on the existence of particular relationships between utility industry participants. Such relationships may be difficult to reproduce in other States. On a regional planning level, however, the relationships between regional groups of utilities may suffice for revelation of information pertinent to inter-regional transmission planning in an Advance Plan-like process for regional transmission. This will be discussed in detail in Section 7.2.

The technological issues that are treated coherently include: radial and network transmission planning, through consideration of a variety of transmission options at different voltages and in different areas; externalities of loop flow; synergies, by considering transmission plans that consist of a number of individual lines; and, economies of scale, through consideration of transmission at various voltages. The PSCW advocates optimization of the network, both for short-term operations and in long-term planning. Long-term state-wide planning to optimize net benefits coherently addresses intertemporal allocation of resources, growth uncertainties, and unsustainability.

### **5.3.2 California Public Utilities Commission Order on Computer Models**

#### ***Description***

In Decision 90-11-052 (CPUC 1990b), the CPUC implemented rules requiring access to computer models and data bases for the CPUC, its Staff, and Parties to CPUC Proceedings. The rules were mandated by California State Assembly Bill 475. We will briefly review the likely effects of these Access Rules from the perspective of the issues of information asymmetries and standards.

The rules ensure that computer models and data bases can be checked for self-consistency and allow parties to check the sensitivity of computer models to changes in input data (CPUC 1990b). Changes to data bases in the course of proceedings must be disclosed.

The rules force parties to reveal the data they have used for studies. To this extent, the problems of consistency of data between various proceedings can be checked, ameliorating this aspect of information asymmetry. However, data used for studies might still be inconsistent with an Applicant's private knowledge. To this extent, the problems of information asymmetries are not completely solved.

The rules also require that computer models and documentation of the models be made available. Though not explicitly requiring standardization, the disclosure rules will probably encourage standardization of data bases and software.

#### ***Summary***

The CPUC Access Rules coherently treats some aspects of the institutional issues of information asymmetries and standardization. We remark that the sheer volume of data used in proceedings may limit the practicality of these Rules. (See Appendix A for a discussion of practicality of disclosing huge amounts of data.)

## **5.4 Federally Adjudicated Cases**

### **5.4.1 Pacific Gas and Electric's Stanislaus Commitments**

#### ***Description***

In the 1970s, a number of individual municipalities and joint action agencies sought participation in large nuclear power plant projects sponsored by IOUs. Statutory authority over anti-trust issues was granted to the Atomic Energy Commission (AEC) and its successor, the Nuclear Regulatory Commission (NRC). To remedy various actions by PG&E that were considered anti-competitive, transmission service was made a licensing condition for a nuclear generation plant in a settlement known as the Stanislaus Commitments, involving the Stanislaus Nuclear Plan. The commitments were originally to be included as part of the operating license for the Stanislaus Plant; however, since Stanislaus was never built, the Commitments were eventually included as conditions in PG&E's operating license for the Diablo Canyon Nuclear Plant (NRC 1981).

The commitments are designed explicitly to limit PG&E's monopoly over transmission in its service area. To this extent, they address competition issues, both inter-utility competition and also competition between PG&E and independent power producers. Among other things, the Commitments oblige PG&E to (NRC 1981):

1. allow participation in ownership of nuclear generating facilities by neighboring facilities;
2. allow interconnection with neighboring utilities for power transfers; and,
3. provide transmission services between, for example, MUNI generation facilities and MUNI service territories that are adjacent to or geographically surrounded by PG&E's 'Retail Service Area'.

The commitments require the building of additional transmission facilities to support transmission transactions; however, PG&E is not obliged to build a facility if equivalent expansion could be undertaken without duplicating any existing PG&E transmission lines, and they do not require PG&E to become a common carrier. The commitments, therefore, deal with network expansion and explicitly rule out radial expansion of PG&E's network.

There is some ambiguity as to whether the Commitments require PG&E to wheel, or simply require it to enter into good faith negotiations over wheeling. However, on two occasions in 1982, PG&E wheeled electricity for short periods under the Stanislaus Commitments and did so without prior negotiation of a transmission agreement (USDC 1989). Tariffs and agreements for these transactions were filed by PG&E with FERC one year after the transactions occurred.

In contrast, in May 1982, Western Area Power Administration (WAPA) contracted to sell energy directly to the Northern California Power Agency (NCPA) on behalf of six city members

of NCPA (USDC 1989). However, PG&E refused to enter into a transmission agreement. Protracted arbitration and litigation ensued, with disputes over, for example, whether the word 'interconnection' when used in the Commitments referred to the fact of electrical interconnection or to the legal notion of an interconnection agreement. The distinction was critical in WAPA and NCPA's contention that PG&E was obliged under the Stanislaus Commitments to provide transmission services without further contractual agreements.

The United States District Court subsequently ruled that PG&E was obliged to wheel for WAPA and that it should file a tariff retroactively at FERC to recover wheeling fees. However, as remarked in the ruling, "time is of the essence in energy transactions" (USDC 1989), while the decision came approximately seven years after the disputed wheeling transaction, which occurred between May and September 1982: it is unlikely that WAPA and others have been encouraged by this experience.

Because disputes over the Stanislaus Commitments are adjudicated in Federal Court, the Commitments are a very unwieldy way to provide transmission access. Tariffs and agreements for even the uncontroversial transactions entered into by PG&E in 1982 took a year to file at FERC. The credibility of the Stanislaus Commitments as workable transmission access agreements is highly questionable: we note that COTP emerged because the MUNIs could not obtain satisfactory transmission access. In contrast, much more direct transmission access guarantees are provided by requirements to file a wheeling tariff at FERC.

### *Summary*

The Stanislaus commitments address the institutional issues of inter-utility competition for transmission access, and competition between PG&E and independent power producers, but do not treat information issues. The technological issue of network reinforcement is treated, but few other issues are resolved. There is little explicit consideration of decision-making complexity. This approach proved to be very ineffective, particularly in contrast to the more rigid and severe approach adopted in the next case of transmission access, which was also mandated through nuclear plant license conditions.

## **5.4.2 Toledo Edison and Cleveland Electric License Conditions**

### *Description*

As with Pacific Gas & Electric's Stanislaus Commitments, the Toledo Edison and Cleveland Electric License Conditions were imposed to mitigate monopoly power. The United States Atomic Safety and Licensing Board found that Cleveland Electric Illuminating Company, Toledo Edison Company, Duquesne Light Company, Ohio Edison Company and its subsidiary Pennsylvania Power Company—the utilities in the Central Area Power Coordinating Pool (CAPCO)—were "guilty of repeated and flagrant violations of the antitrust laws in deal-

ings” (NRC 1979) with their competitors such as MUNIs and Rural Electric Cooperatives in the ‘Combined CAPCO Company Territories’ (CCCT). For example, several of the CAPCO companies refused to wheel power for captive MUNIs that did not otherwise have access to transmission. Furthermore, the MUNIs were discouraged from joining CAPCO to obtain wheeling rights by onerously applied CAPCO membership conditions (NRC 1979).

To rectify the antitrust concerns, the Nuclear Regulatory Commission (NRC) imposed conditions—CAPCO conditions—that are much stronger than the Stanislaus Commitments. As with the Stanislaus Commitments, access to nuclear generation was guaranteed to the MUNIs and Rural Electric Cooperatives in the CCCT; however, the most important differences between the CAPCO conditions and Stanislaus Commitments are that (NRC 1979):

1. the CAPCO conditions are more explicit about the terms of inter-connection agreements, particularly as regards explicit resale rights for transmission services;
2. wheeling tariffs were filed at FERC in response to the conditions, not in response to requests for wheeling service; and,
3. the CAPCO companies must reduce their own transmission transactions, if necessary, to provide for wheeling services to other entities in the CCCT.

The third condition was designed to “prevent the preemption of unused capacity on the lines of one [CAPCO Company] by [another]” (NRC 1979).

It is difficult to judge the magnitude of increased transmission access due to the CAPCO conditions because of the counterfactual nature of assessing transmission access in the absence of the conditions. As a proxy, we will describe developments in the competition between Cleveland Public Power (CPP), a MUNI, and Cleveland Electric Illuminating Company (CEI), a CAPCO Company.

Competition between CPP and CEI for customers in Cleveland is “virtually door-to-door” (CPP 1991), with much of their service areas and distribution systems overlapping geographically. We will not comment on the economic efficiency implications of this unusual arrangement;<sup>17</sup> instead, we will derive some conclusions about transmission access that follow from the particulars of CPP and CEI competition for customers at the distribution system level.

Most of CPP’s bulk power requirements are met by purchases from other utilities (CPP 1991). CEI’s electric rates are generally higher than CPP’s due to “lower-cost power available to CPP and to the exemption from taxation enjoyed by CPP” (SEC 1991). With all else being equal, it would be reasonable to assume that this competitive advantage, combined with the overlapping service areas of CPP and CEI, would have contributed to growth of CPP’s customer base at the expense of CEI’s; however, until the CAPCO conditions came into effect, limited access to

---

<sup>17</sup> In particular, we are *not* asserting that the competition between CPP and CEI is, on balance, beneficial to society.

transmission from CEI prevented growth in CPP's service area. In fact, CPP's customer base decreased through most of the 1970s.

In 1975, a 138 kV intertie provided synchronous inter-connection between CPP and CEI (CPP 1991); however, without wheeling access through CEI to other generation markets, CPP could not increase its access to low-cost wholesale power to expand its customer base. With the CAPCO agreements in place, CPP has recently issued bonds to finance expansion of its distribution system. The increased demand will be met by contracts for supply from the State of New York Power Authority and other suppliers in the region who desire to market excess capacity. These resources will be wheeled over CEI lines under wheeling tariffs filed at FERC as a result of the CAPCO agreements (CPP 1991). CEI recognizes these obligations and is planning its finances and electrical system accordingly (SEC 1991).

### *Summary*

Again, we emphasize that we are not commenting on the economic efficiency implications of the CPP and CEI competition. However, it is clear that the CAPCO conditions have provided transmission access to CPP, and without major disruption to CEI. The conditions treat the institutional issue of wheeling access, but in a very rigid manner.

## **5.4.3 Utah Power and Light-PacifiCorp Merger Conditions**

### *Description*

In 1987, Utah Power and Light and PacifiCorp filed an application with FERC under §203 of the Federal Power Act seeking approval to merge. The service territory of Utah Power and Light was in Utah, Southeastern Idaho, and Southwestern Wyoming, while PacifiCorp's Service territory includes parts of California, Idaho, Montana, Oregon, Washington, and Wyoming. Between them, the two companies owned significant transmission in the path from the Pacific Northwest to the Southwestern United States, including California. The reasons for the merger included economies of scale and scope in operation (FERC 1987).

In their merger application, the companies proposed wheeling conditions to mitigate the anti-competitive effects of their control of transmission, with wheeling priced at embedded costs plus the 'opportunity costs' of foregone transmission. In opinion number 318 (FERC 1988b), the FERC decided that these conditions were inadequate and the merged company was required to offer wheeling service at 'cost-based' rates and to build additional transmission capacity where necessary to accommodate demands for transmission service. The wheeling service conditions were specifically designed to mitigate the monopoly power over transmission that the merged company would gain in its regional market. The conditions therefore consider regional versus state conflicts.



The conditions imposed by FERC had both short-term provisions, lasting for five years, to facilitate an orderly transition from pre- to post-merger, and long-term provisions to assure that any wheeling requirements that could not be met with existing capacity would be met through construction, whether radial or network. In specifying both short- and long-term provisions, the FERC addressed coherently the balance between operation of the existing and planning of the future transmission system. We will describe the short-term conditions first and then the long-term conditions.

The short-term conditions required the merged company to calculate the Remaining Existing Capacity (REC) of the merged company's transmission system that could be made available without new construction. The REC was then divided amongst 'tiers' of potential transmission customers: Transmission Dependent Utilities have a right to 20%; unaffiliated utilities connected to the merged company to the North and East have a right to 30%; and the remaining 50% is available to any utility, including the merged company, where the term 'utility' includes those IPPs that are not QFs.

As noted in Subsection 2.2.2, in its initial decision, the FERC made some attempt to distinguish 'pecuniary' and 'real' benefits of the merger; however, there is no discussion in the FERC record of the specific reasons for the proportions of remaining existing capacity to be allocated to each tier of transmission customer. The allocations seem arbitrary and without a basis in maximizing real benefits. Although the balance between short- and long-term issues is considered, the allocation of tiers does not necessarily improve operating efficiency of the network.

Various arrangements were made in the event of over- or under-subscription of the REC. However, the merged company was specifically precluded from withholding transmission capacity requested for a firm wheeling transaction in order to purchase and resell bulk power (FERC 1988b). This responds to the experiences of the NCPA with interruptible tariffs noted in Section 5.4.1.

In the long-term, legitimately interested parties are afforded the opportunity to jointly participate in transmission construction with the merged company. The merged company is required to meet all bona fide requests for service either with existing capacity or by building new facilities. If service requires new construction, then it must be built within five years of the date of the request, backed up with the provision that if a *bona fide* request for transmission service could not be met within five years, then the merged company would be required to reduce its off-system transactions to satisfy the request. That is, the merged company agreed to put its coordination transactions at risk. Furthermore, long-term contracts for wheeling could not be worded so as to constrain capacity resale rights (FERC 1988b). The transmission service is to be supplied at cost-based rates, not necessarily just embedded costs, but definitely not including 'opportunity costs.' (FERC 1988b).

PacifiCorp later filed its determination of Remaining Existing Capacity and a tariff with FERC (FERC 1990). A refiled tariff was subsequently accepted and made retroactively effective

from June 12, 1989 (PacifiCorp 1991a). There are tariffs for both firm and non-firm service. The firm tariffs, for example, consist of (PacifiCorp 1991a):

- a facility cost, based on embedded costs, with rates in the range \$30—\$40 per kW-year, depending on the duration and path of service, and,
- compensation for losses, based on system average losses. The assessment for losses is between 4% and 8% of actual energy delivered, depending on the voltage and path of service.

Compensation for losses is independent of actual or prevailing loading conditions, so that, for example, loss charges are assessed for a wheeling transaction that is counter to the flow of existing power, even though counter-flow wheeling actually reduces losses (PacifiCorp 1991b). While the tariff guarantees access, it does not give economically efficient incentives to wheeling customers.

As of July 1991, eight utilities have executed transmission agreements with PacifiCorp for REC (PacifiCorp 1991a). The tariff filed by PacifiCorp has evidently been successful in attracting transmission customers.

Since PacifiCorp determines its own Remaining Existing Capacity, there is a significant information asymmetry. However, as of June 1990, the transmission service in the three tiers is under-subscribed (FERC 1990) and almost all transmission paths continued to be under-subscribed as of August 1991 (Corey 1991). PacifiCorp has not needed to build or plan for any transmission lines in order to satisfy transmission requests. Ironically, this is *prima facie* evidence that PacifiCorp's transmission system may be significantly overbuilt. Practically speaking, therefore, there is no pressing need to question PacifiCorp's figures; however, several parties suspect that the REC is understated (FERC 1990), and there is apparently no provision for independent verification of the basis for REC calculations.

### **Summary**

The short-term success of the merger conditions in creating transmission access indicates the potential of FERC-based mandated access. Such access seems to function more smoothly than, for example, access under the Stanislaus conditions, while being less onerous to the wheeling utility than the CAPCO agreements. In the long term, however, as REC is used up, the calculations may become more contentious and the information asymmetry more problematic.

The merger conditions coherently treat the institutional issues of inter-utility competition, competition between PacifiCorp and independent power producers, and state versus regional issues, but do not treat information asymmetries. The technology issues of radial and network reinforcement are treated to the extent that the merged company itself performs comprehensive transmission planning; however, the issues of economies of scope and scale are not treated perfectly, since embedded costs and average losses are used as the basis for the tariff. While

the balance of short-term and long-term issues are considered in the tariff, neither efficient operations nor optimal long-term planning is encouraged by the conditions.

## **5.5 Synopsis**

Table 5-1 summarizes the issues treated coherently in the Utility proposals and frameworks, State legislation, and Federal adjudication. As the table makes clear, the Vermont Electric Transmission Company (VELCO) and the PG&E multi-attribute bidding framework, on the industry side, and the Wisconsin Advance Plan (WAP) on the state policy side, are the most coherent and comprehensive approaches to transmission planning that we have discussed here. VELCO and the WAP are primarily institutional frameworks for transmission planning, while operation, while the PG&E multi-attribute bidding framework is a concrete implementation of utility planning. The problem for policy in other regions is finding a way to create frameworks and implementations that can achieve similar benefits.

**Table 5-1  
Issues Treated Coherently by Utility, State and Federal Policy**

Category	Issue	Features	V E L	W S P	L P P	P G E	W A P	M O D	S T A	T E C	U - P	
Institutional	Competition	Wheeling Access for TDUs	X				X		X	X	X	
		Independent Power				X			X		X	
	Regulation	Asymmetric Constraints	X				X					
		State and Regional Conflicts										X
		Pecuniary versus Real Benefits	X				X	X				
	Information Asymmetries		X		X	X	X	X				
	Standards		X	X	X	X	X	X				
Technology	Line Characteristics	Radial	X			X	X				X	
		Network	X				X		X		X	
	Network	Negative	X		X	X	X					
		Positive	X				X					
	Externalities	Synergies	X				X					
	Structure of Scale	Inter-temporal Allocation	X				X					
		Growth Uncertainties	X				X					
Unsustainability		X				X						
Economies of Scope		X				X						
Decision-Making Complexity	Feasibility versus Optimality	Operations				X	X					
		Planning	X			X	X					
	Operations and Planning		X			X	X				X	

**Key:**

VEL	Vermont Electric Power Company	MOD	CPUC Order on Models
WSP	Western Systems Power Pool	STA	PG&E Stanislaus Commitments
LPP	Large Public Power Council	TEC	Toledo Edison and Cleveland Electric License Conditions
PG&E	PG&E's multi-attribute bidding framework	U-P	Utah Power and Light-PacifiCorp Merger Commitments
WAP	Wisconsin Advance Plan		

## Chapter 6

# Technical Analysis in Transmission Planning

### 6.1 Overview

In the previous chapters, we have remarked on the issue of standardization of assessment of costs and benefits. A pre-requisite to standardization is a solid theoretical basis for transmission planning. In this chapter we outline transmission planning, both:

- theoretically as described in Stoll (1989), and,
- as practiced by utilities in evaluating the transmission needs of wheeling transactions and for purchases of independent power.

The description of theory provides a basis to evaluate transmission planning in practice. We then survey four software packages used in utility and regulatory analysis of transmission issues. First, two planning models:

- the Decision Focus Incorporated (DFI) model of generation and transmission expansion in California and surrounding regions (DFI), and,
- the PG&E LOCATION incremental transmission impact evaluation program;

then, two operational models:

- the Meta Systems WRATES transmission spot pricing model, and,
- the Sierra Energy and Risk Assessment model (SERAM) of surplus energy resources available to California.

Although the DFI, LOCATION, and SERAM models are adapted to specific regions, their design principles and features could be applied in other regions.

We will see that the theory, practice, and software packages we review completely omit the issue of information asymmetry. In fact, most of the institutional issues described in Section 2.2 are essentially outside their purview; whether or not they are dealt with coherently typically depends on the use to which these are put, not their intrinsic characteristics. For example, PG&E's LOCATION program, itself, does not resolve the issue of competition between utilities and independent power, but this issue is considered in PG&E's multi-attribute bidding framework, of which LOCATION is an important part.

Most of the theory, practice, and software packages also omit issues such as economies of scale and scope. However, in this chapter, we will concentrate on the strengths of the theory, practice, and software and defer discussion of information asymmetries and other economic

issues to the appendix, where we also provide a perspective on the need for large scale optimization models in transmission planning.

## **6.2 Theoretical Long-Term Transmission Planning Under Vertical-Integration**

In this subsection, we outline a textbook description of the process of long-term least-cost transmission planning by a vertically-integrated utility, essentially paraphrasing Stoll (1989), a state-of-the-art reference.

As described in Section 2.3, the transmission network is typically expanded in complex patterns. The basic reason is that the economies of scale of construction dictate that transmission is added in large increments between pairs of nodes in the system, while demand growth tends to occur gradually throughout the system. The optimal planning of the transmission network is, in principle, a large-scale stochastic dynamic programming problem (Larson and Casti 1978). The objective is the present value of the sum of construction and operation costs. Constraints are imposed by the loadflow equations, demand requirements, generator limits, thermal line limits, steady-state and transient stability limits, and various other issues. The decision variables are the choices to build or increase transmission capacity between pairs of nodes at any time. The stochastic nature is due to uncertainties about future demand scenarios and fuel and construction costs.

A typical large utility or region may have several thousand buses and lines, and hundreds of generators. Lines can potentially be added between many pairs of nodes. Because the lifetime of typical generators is 20—40 years, while lines have lifetimes of 40—70 years, and since the size of a large line may be several times the total amount of system load growth in a year, optimal planning requires a planning horizon far into the future.

As a proxy to such very long-term planning, a 'horizon-year' may be chosen that is only ten to twenty years into the future. In general, truncation of planning to a finite horizon will preclude an optimal design. Under some circumstances, however, planning horizons can be chosen that are far enough into the future so that optimal initial decisions can be made. Theoretical conditions for such planning horizons to exist are contained in (Bean and Smith 1984). Unfortunately, it seems unlikely that these conditions are satisfied by a typical transmission planning horizon-year, so that the chosen horizon-year can at best be considered only a rough approximation to very long-term planning.

Once the horizon-year is chosen, load forecasts and generation alternatives for the horizon year are compiled. Additions to the current transmission system are then designed to satisfy transmission criteria. Ideally, the generation and transmission additions would be designed jointly for this horizon-year system.

The transmission planning criteria vary from utility to utility; however, a representative set of criteria is as follows: the basic consideration is that, under normal conditions, with all transmission lines in-service, there must not be any overloads of any equipment or lines, where the limits are based on both thermal and stability limits. Furthermore, voltages at all buses must be within operating range.

Additionally, after any single outage of a line it is required that:

1. there are no overloads on lines past emergency limits and there are no violation of reactive power generation limits;
2. there are no transient or dynamic stability problems, and transient and steady state voltages are acceptable;
3. there is no under-frequency load-shedding; and finally, that
4. there are no cascading outages.

This group of criteria are collectively referred to as N-1 criteria, since they consider the outage of one of the total of N lines in the system. As well as these criteria, certain double contingencies may also be considered; these criteria are referred to as N-2 criteria.

Designing the optimal horizon-year plan directly is far beyond current computational capacity. Moreover, the uncertainty of many future parameters would reduce the value of such analysis. Instead, only approximately optimal planning of the horizon-year system is possible.

To illustrate why an approximate approach is necessary, Stoll (1989) describes the multiplicity of issues that must be considered even in a radial transmission project. Paraphrasing Stoll, suppose that the planning requirements in a system include the future need to transmit 1000 MW over a 320 km right-of-way. We assume that there are two candidate line voltages, 345 kV and 500 kV.

First, Stoll observes that, based on line ratings, either a single 500 kV line or two 345 kV lines would suffice to carry the power. These costs are shown in Table 6-1. On this basis, the economies of scale of construction make the 500 kV line cheaper. However, Stoll then notes that a single contingency of a line would cause loss of service.

While two 345 kV lines or one 500 kV line will not satisfy the N-1 criteria, adding one more line in parallel to either the 345 kV lines or 500 kV line would remedy this problem. The capital costs of either two 500 kV lines or three 345 kV lines are approximately the same, so that the economy of scale advantage of higher voltage lines is off-set by the contingency problems imposed by their higher capacity rating.

Stoll then considers losses. The higher voltage lines have considerably lower losses and this makes the 500 kV lines cheaper overall over the life of the transmission line. This trade-off between capital costs and losses depends on estimates of line loading. Finally, Stoll goes on

to illustrate the further complexities that arise if network transmission expansion is required (Stoll 1989).

This example has only considered a few of the issues involved in transmission. The point of the example is that many interacting factors all need to be considered to evaluate the benefits and costs of a line. As in the DPV2 study, the consideration of only some of the issues can significantly alter comparisons between alternatives; however, the more thoroughly each option

**Table 6-1**  
**Costs of Transmission Construction**

Construction Plan	Voltage/kV	
	345	500
Minimum construction for 1000 MW capacity	198 <sup>1</sup>	149
Construction to satisfy N-1 criteria	297 <sup>2</sup>	298 <sup>3</sup>
Construction to satisfy N-1 criteria plus capitalized cost of losses	341	311

Source: Sections 16.11 and 16.12 of Stoll (1989).

Notes:

<sup>1</sup> Two 345 kV lines required to transmit 1000 MW

<sup>2</sup> Three 345 kV lines required to survive single contingency

<sup>3</sup> Two 500 kV lines required to survive single contingency

is to be analyzed, the fewer the number of options that can be handled with a reasonable amount of effort.

Recently, there have been integer-programming implementations of optimal design of horizon-year systems that in principle can consider all the issues and optimize over all options. See, for example, Boffey and Green (1983), Santos et al. (1989), and Villasana (1984); however, the work has not found large-scale acceptance in the utility industry and there is apparently no commercially available software.

Instead, a multi-stage approach is used in practice to design an approximately optimal horizon-year system. At each stage many constraints and the objective are represented by rough proxies. For example, line limits may be based on thermal limits that are derated to approximately represent stability limits. Production costs may be approximated through simulation of operations using a simplified unit commitment schedule.

At each stage, alternatives that don't satisfy constraints or which are very expensive are eliminated. At the next stage a more detailed model of the constraints and objective can then be examined and optimized over a smaller number of remaining candidate solutions. The



procedure is illustrated in Figure 6-1 and yields a suboptimal, but hopefully reasonably good horizon-year transmission plan.

After the horizon-year system is planned, “a yearly transmission plan can be developed that builds toward the horizon year” (Stoll 1989). The yearly planning problem is now a finite horizon dynamic program with a relatively few decision variables: basically, whether or not to build each of the horizon-year lines in any given year. This is a much simpler problem than considering all possible construction projects. Of course, the drawback is that there is no guarantee of optimality, but if the planning procedure is repeated every few years, then a reasonable plan can be mapped out that can adapt to changes in future transmission requirements as they are revealed.

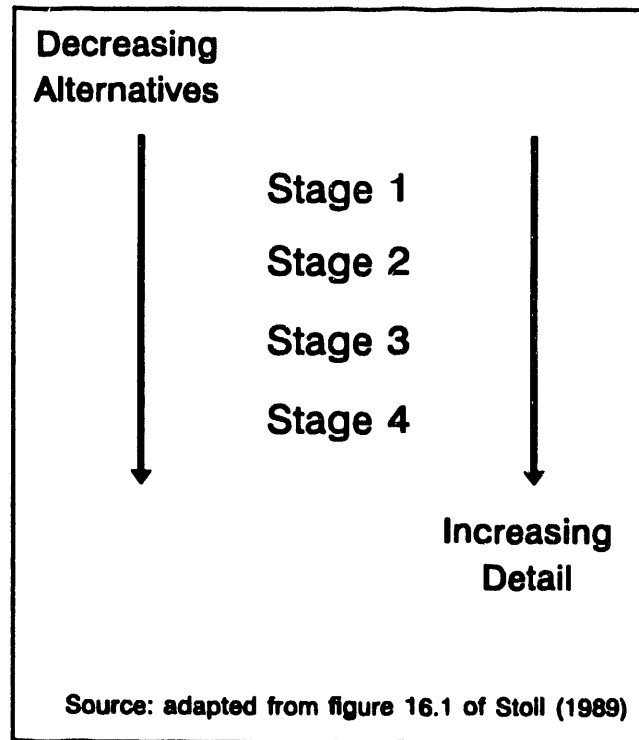

**Figure 6-1**  
**Multi-Stage Transmission Planning**

The generic process described here can potentially incorporate all of the technological issues described in Chapter 2, so that its treatment of the decision-making complexity is a matter of design. We have remarked that the institutional issues are external to the theoretical treatment here.

Planning for wheeling and independent power can potentially be handled in this framework if:

1. the growth of independent power and wheeling needs is known in advance and can be explicitly taken into consideration in the long-term plans, or,
2. the potential for growth is relatively small so that the transmission needs can be treated as perturbations on the overall plan, as in the Pacific Gas & Electric LOCATION program to be discussed in Section 6.4.

Clearly, serious problems can arise if, instead, there is growth in the transmission needs of independent power that is too large to be treated as a perturbation on long-term plans, but too sudden or unexpected to be coherently incorporated into long-term planning. The Kramer-Victor case is an example. In the next section, we will observe that the treatment of transmission issues for wheeling and independent power is usually not fully integrated into long-term planning.

### **6.3 Transmission Planning by Utilities for Wheeling and Independent Power**

In this section we discuss the planning methodologies used by several utilities in evaluating transmission expansion required for wheeling transactions and for purchases of independent power acquired through competitive bidding. The description is based on the transmission planning examples presented at the California Public Utilities Commission (CPUC) series of Workshops in Transmission Access that took place in August 1991. Four presentations, by representatives of Pacific Gas & Electric (PG&E 1991a), Southern California Edison (SCE 1991), San Diego Gas and Electric (SDG&E 1991), and Sierra Pacific Power Company (SPPC 1991) are summarized here.

Generally, the transmission analysis for wheeling and purchase agreements is of shorter term than the long-term transmission planning described in the last section; however, all the engineering issues must be addressed in detail. It is usually carried out in response to a specific request for transmission service, rather than being part of long-term transmission planning.

The basic analysis consists of several steps. First, a test year or a few test years are established. It is verified that the existing system, or the currently planned test year systems, can satisfy the criteria outlined in the previous section, without the additional transmission transaction. The choice of test year varies from utility to utility.

Secondly, interconnection and transmission upgrade alternatives are selected, based on 'engineering judgment.' Some consideration is given to long-term transmission expansion in the selection of the alternatives. For example, if further transmission requirements are expected along a transmission corridor, then alternatives with higher ratings or at higher voltages may be considered. In the Kramer-Victor case, for example, overbuilding of towers was used to provide for future requirements. However, the upgrade alternatives are rarely optimized with respect to a long-term perspective.

Thirdly, the existing system is modified to include the wheeling or power purchase under consideration. Power flows and stability analyses are performed on the modified system under the various transmission upgrade alternatives. A no-upgrade case is also considered. The criteria discussed above are applied to the modified system. Transmission alternatives that fail any criteria are eliminated from consideration. Fourthly, an economic comparison is made between the feasible alternatives.

The basic difference between this planning methodology and the planning described in Section 6.2 is that there is no consideration of a horizon year that is well into the future. Instead, one or a few test years are considered that may represent the system for only five or ten years into the future. The planning is usually less integrated with other supply, transmission, and demand-side decisions. For example, the single system for each test year cannot represent the range of possible generation resources acquired in future long-term competitive bidding processes.

As in Section 6.2, on theoretical transmission planning, any of the technological issues can be incorporated; however, efficient planning is not apparently as strongly pursued as described in Section 6.2 and, furthermore, the choice of nearby test-years precludes an optimal long-term plan. Again, institutional issues are external to the modeling.

## **6.4 Transmission Planning Software Models**

### **6.4.1 The Decision Focus Incorporated (DFI) Model**

This model was developed under contract by Decision Focus Incorporated (DFI) for the California Energy Commission to assess the benefits of currently proposed additions to transmission capacity both wholly inside California and “between California demand regions and out-of-state supply sources” (DFI 1990). As described in (DFI 1990), “[t]he model is formulated as a linear program with the objective of minimizing the present value of the cost (investment plus operating) of meeting the demand for electricity in the seven regions over the period from 1990 to 2010” (DFI 1990).

It is a planning model. The objective is jointly optimized over both inter-regional transmission capacity additions and regional generation and demand-side management additions over a planning horizon. The constraints include energy balance, reserve margin, hydroelectric energy availability, and transmission limitations.

The modeled transmission projects include (DFI 1990):

- Devers-Palo Verde 2;
- the California-Oregon Transmission Project (COTP);
- “South of Tesla reinforcements designed in part to extent [sic] the delivery capability of COTP to Southern California” (DFI 1990);
- the Adelanto-Mead-Phoenix area interconnection and the McCullough Northward interconnection; and,
- the Trans Sierra connection between California and Nevada.

These projects include two of our case studies. The modeled transmission links are shown in Figure 6-2. The links join the seven modeled regions within and surrounding California. All links were candidates for expansion. Generation additions were modeled as generic plants in each of the regions.

Costs of resources are based on (DFI 1990):

- price and availability of gas and coal and the environmental costs of and constraints on gas and coal use in California;
- costs of inter-regional transfer capacity, including environmental and other costs;

- cost, availability, and environmental consequences of out-of-state supply sources; and,
- current and future demand and the cost of demand-side options.

Other model features include (DFI 1990):

- seasonal and daily demand variation, through 12 load demand levels;
- multiple Pacific Northwest hydro conditions;
- maintenance scheduling;
- forced outages, through derating; and,
- reserve margins.

The DFI model optimizes over a broad range of electricity system construction options and over a long planning horizon, and considers various scenarios (DFI 1990). It represents transmission as a capacitated transshipment network (Lawler 1976); that is, the network is modeled as a set of nodes joined by links. Each link has a rated capacity and a per unit cost of transmission to represent losses, with an assumed constant percentage loss per unit length of line. Network externalities such as parallel flow are not treated. Synergies can be treated to the extent that they can be represented with a linear objective and constraints. True transmission network planning is not undertaken since links are treated as though each were a radial connection. Economies of scale in transmission construction are not modeled, and in fact, the model description underplays their relevance (DFI 1990); however, the reason for not treating economies of scale seems to be related to computational tractability. Economies of scope in operation are treated by the transmission model; however, since most of the energy flows towards California, this feature does not affect results significantly.

The DFI “approach is essentially a large-scale economic equilibrium model” (DFI 1990); however, because institutional constraints are deliberately avoided, competitive issues are omitted: the model treats all regions as if they are collectively planned and centrally dispatched to maximize total welfare, so that real benefits are considered and operations and planning are jointly optimized. Each model scenario is run separately and planning is done for a given scenario under perfect foresight, so that the dynamics of decision making and aspects of risk hedging are not modeled (DFI 1990). To the extent that the cost data is correct and transmission

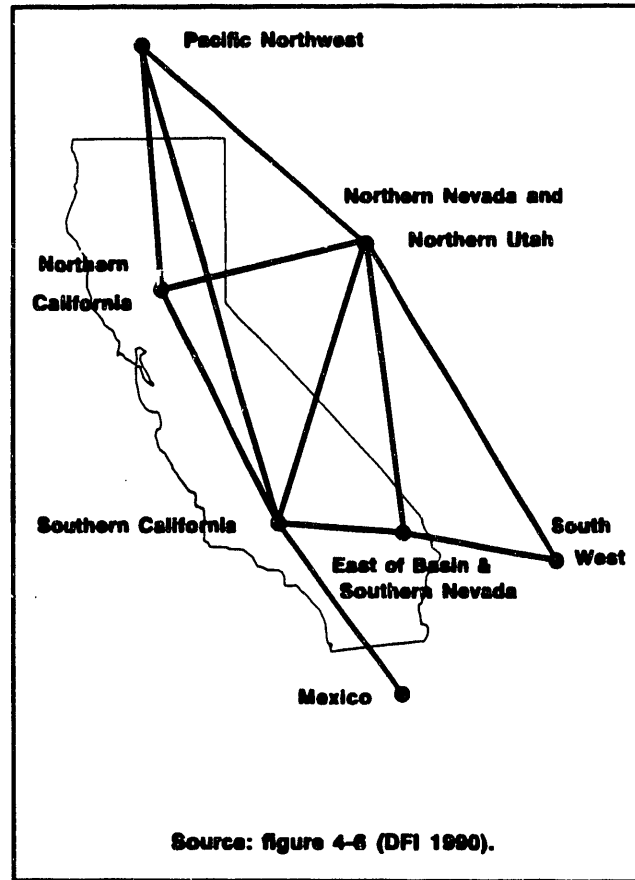

**Figure 6-2**  
**DFI Representation of Lines**

is modeled adequately, the results therefore represent an optimistic lower bound to the costs actually achievable under institutional constraints with imperfect forecasts of the future.

Despite the many details included in the model, it currently does not describe many significant aspects of transmission and generation planning, including risk hedging over uncertain forecasts and economies of scale. It does not model generator operating costs in detail. Given the regional emphasis of the model, it might also incorporate analysis of gas as well as electric transmission.

Of course, adding such features can be expected to significantly increase the difficulty of performing an optimization over various construction options. Nevertheless, the DFI model illustrates a coherent approach to tackling long-term statewide and regional issues, which, for example, the CPUC has been unwilling or unable to do. Many of the operational modeling features described in the next subsection could, in principle, be incorporated into the DFI model. The DFI model coherently addresses the technological issues of radial expansion and economies of scope. Operations and planning are jointly optimized.

#### **6.4.2 Pacific Gas and Electric LOCATION Program**

PG&E's LOCATION program estimates the transmission costs and benefits of new generation resources. It is part of PG&E's multi-attribute bidding framework, which was described in Section 5.2.4. LOCATION performs sensitivity analysis on the solution to an optimal power flow (OPF) (Stevenson 1982) to estimate the cost of incremental additions in generation at any bus in the PG&E system. Like the DFI model, LOCATION coherently integrates both generation and transmission costs and benefits, but is more rigorous in its treatment of network considerations.

A major feature of LOCATION is that, by using incremental analysis, it does not require prior information about potential bidders. LOCATION requires data only on:

1. a base-case of transmission and generation resources relevant to a study date, and,
2. the average costs of facility upgrades.

An OPF is solved to optimally dispatch the base-case. That is, system operation is optimized to minimize production costs, while respecting line and other constraints. Then optimal planning is approximated based on the OPF solution, through a sensitivity analysis. The sensitivity analysis estimates the effect on losses and loading due to an incremental injection at any bus. The analysis is described in detail in Gribik et al. (1990).

The OPF coherently incorporates externalities and economies of scope of operation. That is, network aspects of transmission operation are modeled. Incremental additions that impact line limits are considered by assuming a per unit cost for transmission additions along any overloaded

line, ignoring economies of scale and lumpiness. As with the DFI model, this approach essentially assumes that all expansions are radial.

In the case of the DFI model, network expansion issues were apparently ignored for reasons of computational speed. However, in the PG&E model, these issues are suppressed so that transmission cost estimates can be provided to the bidders in advance of the bidders submitting their bids. This represents a deliberate choice to suppress non-linearities in order to make the bidding transparent, permitting the bidders to tailor their bids to the utility's decision process. The approximation is good to the extent that the additions are relatively small.

In summary, LOCATION treats the technological characteristics of negative network externalities and economies of scope, but, because of its application in transparent bidding, does not perform true network planning, nor consider economies of scale. It can be used to jointly optimize both operations and planning. It is a theoretically sound approach where generation additions and transmission impacts are incremental.

## **6.5 Transmission Operations Models**

### **6.5.1 Wheeling Rate Evaluation Simulator (WRATES)**

WRATES was developed by Meta Systems, Inc. (MSI) under contract to the New York State Energy Research and Development Authority (Roukos and Caramanis 1988). It models the operation of an electric system. The WRATES software embodies the ideas in Schweppe et al. (1988) applied to wheeling of electricity. WRATES evaluates wheeling rates based on marginal operating costs with a revenue reconciliation factor for capital recovery (Roukos and Caramanis 1988).

WRATES uses a modified direct current (DC) loadflow (Schweppe et al. 1988) that incorporates an estimation of losses to approximately represent up to a 25 bus and 200 line network. It can model power pools. Network externalities are approximately represented through the DC loadflow. WRATES can be run on a personal computer (PC), while the results from a full load flow on a larger network can be downloaded to the PC and used to approximate wheeling on the larger network. It determines wheeling rates based on (Roukos and Caramanis 1988):

- user-specified bus demands;
- user-specified production costs;
- user-specified costs of unserved energy;
- line losses depending on line loading, but calculated approximately; and,
- user-specified line and generator capacity constraints.

Marginal-cost based rates treat economies of scope of operation coherently. Since the marginal-cost based rates will not in general exactly recover total capital and operating costs, WRATES incorporates 'revenue-reconciliation' factors to multiply the prices so that revenues recover costs.

The generation cost, demand, and network data are provided through a base-case and a set of scenarios that represent the various outage and configuration states of the system during a test year. The wheeling rates are calculated for each condition and an average wheeling rate is calculated based on the user-specified probabilities of each scenario. WRATES can generate a graph of wheeling rates versus duration in the year.

WRATES is designed as a normative policy tool, “programmed for the evaluation of simplified networks” (Roukos and Ceramanis 1988). It deals with operational considerations, treating negative network externalities and economies of scope coherently through an explicit loadflow representation, and seeking optimal rates based on real benefits. It does not treat information asymmetry aspects, since it assumes that production cost and line limit information is known. It models independently controlled power pools and calculates wheeling rates that consider the cost of transmission losses, but does not consider strategic behavior.

### **6.5.2 Surplus Energy Resource Assessment Model (SERAM)**

SERAM is a public domain computer model, developed by Sierra Energy and Risk Assessment (SERA) under contract to the CPUC, and designed to be run on a personal computer. It is a model of the operation of the California and surrounding regional electricity system. SERAM evaluates the “availability and transportability” (SERA 1991a) of Desert Southwest (DSW) and Pacific Northwest (PNW) surplus energy. It “models the loads, resources, interconnected transmission systems, and firm power commitments of each major region in the [Western Systems Coordinating Council] to determine the quantity and price of economy energy ultimately available to California utilities” (Schoonyan et al. 1991).

The available DSW energy and costs are determined by calculating potential generation from coal and nuclear plants that is surplus to indigenous requirements and firm sales. The available PNW surplus is modeled with reference to a suite of historical stream flow conditions. Surplus from PNW hydro or coal units is made available for sale out of the region (SERA 1991a).

The transfers from PNW and DSW into California are determined on the basis of (Schoonyan et al. 1991, SERA 1991a):

1. economy energy demand curves for each purchasing utility;
2. blocks of DSW power in excess of calculated DSW regional demand, priced at average incremental generation costs;
3. blocks of PNW hydroelectric power in excess of calculated PNW regional demand, priced at user-defined prices;
4. blocks of PNW coal power in excess of calculated PNW regional demand, priced at the average cost of coal units; and,
5. transmission system limits and ownership and participation rights.

Calculation of environmental emissions is also being incorporated into the model. The modeled transmission links are shown in Figure 6-3. As with the DFI model, the transmission network is modeled as a capacitated transshipment network (Lawler 1976); however, the model is more complete, with adjustments for (SERA 1991b):

- parallel flow;
- simultaneous import limits;
- constant percentage losses; and,
- certain other operational considerations.

In general, the SERAM model treats transmission in more detail than the DFI model, but not in as much detail as LOCATION. The modeling of transmission participation rights models the operational aspects of inter-utility competition.

SERAM allows the estimation of the benefits of economy energy transactions based on a given transmission system configuration. It coherently models the externalities of electric operations, but does not directly address planning issues. By design, SERAM evaluates the pecuniary benefits of transmission operation.

## 6.6 Summary

The characteristics of the software packages are summarized in Table 6-2. By design, the operational models do not treat planning considerations such as reinforcement of the grid and economies of scale in construction. The planning models do not address economies of scale and only treat radial line expansion.

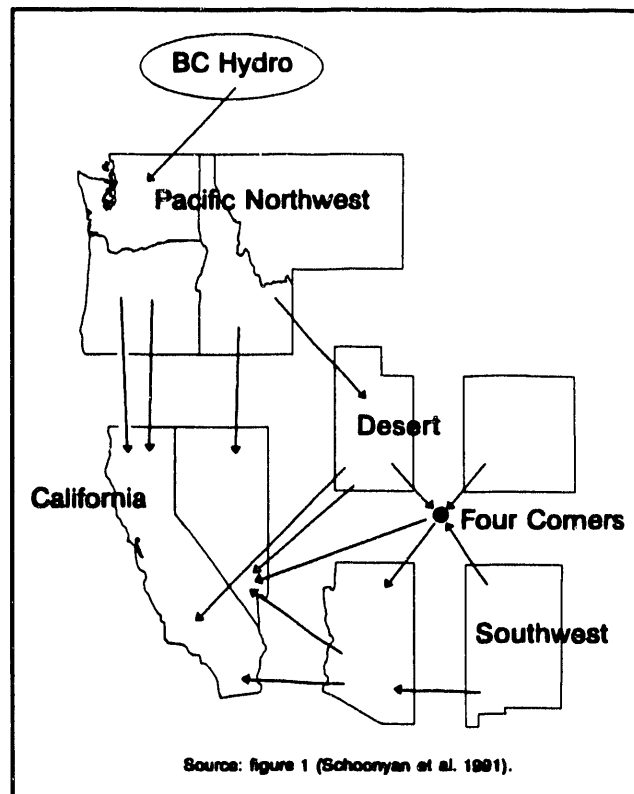

**Figure 6-3**  
**SERAM Representation of Lines**



**Table 6-2  
Issues Treated Coherently by Software Packages**

Category	Issue	Features	D F I	L O C	W R A	S E R
Technology	Line	Radial	X	X		
	Characteristics	Network				
	Network	Negative		X	X	X
	Externalities	Positive				
		Synergies		X		
Structure	Economies of Scale	Intertemporal Allocation				
		Growth Uncertainties				
		Unsustainability				
	Economies of Scope		X	X	X	X
Decision- Making Complexity	Feasibility versus	Operations	X	X	X	X
		Planning	X	X		
	Optimality	Operations and Planning	X	X		

**Key:**      DFI                      Decision Focus Incorporated Model  
               LOC                    PG&E LOCATION program  
               WRA                   Meta Systems WRATES  
               SER                    Sierra Energy and Risk Assessment SERAM



## **Chapter 7**

# **Conclusions and Suggestions**

This chapter is divided into two sections. In Section 7.1, we make several general observations about the case studies from Chapters 3 and 4. In Section 7.2, we discuss the ways in which the proposals described in Chapter 5 could be combined to address the issues raised in Chapter 2. We also suggest directions for development of enhanced software to support transmission planning.

### **7.1 Generalizations From the Case Studies**

In this section, we describe three general issues:

1. the limited treatment of transmission in most utility integrated resource plans;
2. the tensions between regulation and competition; and,
3. the issue of private information.

The limited treatment of transmission in most of the integrated resource plans described in Chapter 3 is in contrast with the detailed analysis of individual projects that takes place for certification of the lines as described in Chapter 4. Even the more detailed analyses of Niagara Mohawk and PG&E's Delta Project take potential construction plans as given, with well-defined costs and benefits. Some amount of approximation and simplification is to be expected in an overall plan and so it is natural for the analysis of individual lines to be in greater detail than the analysis of transmission in an Integrated Resource Plan (IRP). However, in several cases in Chapter 4, the economic analysis of the line or proposal changed fundamentally over the course of the regulatory proceedings. If the lines had been part of an integrated resource plan, then the changes in the economics of the lines may have seriously changed the economics of the whole IRP.

For example, changed in-service dates and changed assessments of benefits and costs of transmission could reasonably be expected to affect the timing of other resources. In the case of Kramer-Victor, the delays in siting of necessary transmission have seriously affected the financial viability of Luz and Cal Energy, which would in turn affect assessments of the contributions of these qualifying facilities (QFs) to generation. In contrast, in the IRPs analyzed in Chapter 3 transmission is accorded a secondary role.

We next turn to the tension inherent in transmission planning due to regulation and competition. Under traditional rate of return regulation, profit-maximizing transmission-owning utilities (TOUs) have two apparently conflicting desires:

1. according to Averch-Johnson analysis (Averch and Johnson 1962), profit maximization encourages them to over-invest in capital to the extent that it can be rate-based, while,
2. to limit competition from independent producers and other utilities in the generation sector, the utilities are motivated to undersupply transmission service, even if there is excess capacity available.

As we have demonstrated in the Kramer-Victor and California-Oregon Transmission Project (COTP) case studies, these goals are not necessarily incompatible:

- In Kramer-Victor, Southern California Edison (SCE) obtained certification to invest in and ratebase considerable transmission in excess of that needed by Luz and Cal Energy, but also limited the participation and ownership of lines by Luz and Cal Energy.
- In COTP, it is possible that the Pacific Intertie capacity could have been increased much more economically by expansion remote from the Pacific Northwest, while the investor-owned utilities (IOUs) wanted to limit the Pacific Intertie capacity owned by competitors.

These examples illustrate the potential problems in a regulated monopoly interacting with unregulated participants or participants bound by different regulatory constraints. The Duquesne/GPU project also combines elements of regulated and unregulated ventures. Perhaps surprisingly, the contractual arrangements of the Duquesne/GPU project may be able to avoid some of the institutional conflict that has arisen in the California Case Studies.

Secondly, we discuss information asymmetries. In DPV2, and to a lesser extent K-V, regulatory proceedings relied on considerable information that was private to the utility and which only gradually, if ever, became public knowledge. The issue of private information has been emphasized throughout this report and its resolution is central to the successful treatment of transmission.

## **7.2 Potential Solutions and Suggestions**

The initiatives summarized in Table 5-1 are all potential candidates for solving the problems raised by the case studies in Chapters 3 and 4. None of the initiatives address all the issues; however, combinations of several of them could collectively address them all. A promising model is the Wisconsin Advance Plan (WAP), but the success of the WAP depends on:

1. comprehensive jurisdiction in Wisconsin; and,
2. relatively equal competitive positions among the utilities that effectively discipline them to truthfully reveal their characteristics.

The Public Service Commission of Wisconsin's (PSCW's) comprehensive regulatory power has enabled it to set up a planning process that can, in principle, incorporate all issues while balancing protagonists' interests. Furthermore, there is possibly enough equality between individual Wisconsin utilities so that competition can discipline their submissions to the PSCW.

However, the PSCW's regulatory power should be strongly contrasted with, for example, the regulatory jurisdiction in California, where only IOU participation in transmission projects is regulated. Direct application of many aspects of the Advance Plan process in states other than Wisconsin would therefore require changes to laws. The structure of the Vermont Electric Transmission Company (VELCO) company or voluntary associations such as the Large Public Power Council (LPPC) or the Western Association for Transmission Systems Coordination (WATSCO) may be a viable alternative for embodying the Advance Plan principles, while also avoiding the need for legislative changes.

The information issue is more problematic. In the case of Wisconsin, the Wisconsin utilities have pooled their collective knowledge of system loadflow and generation data pertaining to Wisconsin and most of the rest of the Midwest in order to facilitate transmission studies. While each Wisconsin utility might individually want to restrict access to information about its system, the discipline of multiple protagonists of approximately equal size and expertise helps to reveal the information needed for the WAP process.

In a transmission market such as California, however, there are several large players competing with much smaller utilities such as publicly owned municipal utilities (MUNIs). The MUNIs may not have sufficient resources to review IOU submissions for veracity and to participate in joint planning. In the presence of information asymmetries it may be difficult for a MUNI to translate its feeling that it is being unfairly treated into a verifiable complaint to the regulators: in the case studies in Chapter 3 there are several examples of the difficulty in obtaining truthful revelation of costs and benefits from the IOUs, both due, apparently, to deliberate strategic manipulations and also simply because there is so much data involved in assessing transmission capacity.

The Wisconsin Advance Plan model may therefore be more applicable at the inter-regional planning level, where each region could pool enough resources collectively to perform adequate technical studies of inter-regional transmission. We argue that competing regional interests would possess enough resources to perform inter-regional analyses that would discipline submissions to a planning body. The main concern of an inter-regional planning body would be to provide adequate inter-regional transmission capacity, while avoiding major over-spending on capital projects. A voluntary inter-regional association, such as WATSCO (WATSCO 1991), or a company, along the lines of VELCO, could provide a forum for this planning without significant legislative changes and without ongoing litigation over transmission access.

At the intra-regional level, we agree with the Federal Energy Regulatory Commission (FERC) Transmission Task Force Report (FERC 1989) in suggesting that slight over-building of transmission may be a small price to pay for competition in generation. This would mesh well

with an intra-utility resource acquisition framework such as PG&E's multi-attribute bidding framework, which, we have argued, functions best in the presence of some excess transmission capacity. Furthermore, issues such as transmission access for independent power, which are not prominent in the Advance Plan Process, could be resolved through a framework such as PG&E's.

Summarizing these observations, the role of transmission associations and companies, and of regulation would be restricted to two areas:

1. prevent major over-building at the inter-regional scale, and,
2. encourage minor over-building at the intra-regional scale, both between utilities and within a given utility's transmission network to accommodate transmission transactions.

We propose that large transmission projects would be evaluated by a regional association in the same way as the Wisconsin Interface Study. Problems such as externalities would fall naturally within the compass of a regional planning body. Intra-regional planning could be pursued to a great extent under existing state regulation; however, to solve issues such as asymmetric regulatory constraints, legislative changes would be required in some states.

Several issues remain that seem problematic, including optimal network expansion planning considering economies of scale and uncertainties in growth. The large-scale transmission planning software models we have reviewed approximate network expansion by assuming that lines are radial and by ignoring economies of scale. The reason for these approximations is ultimately the complexity of optimal network expansion, both computationally and because of the information burden it imposes, particularly as regards future demand and generation scenarios. While there is considerable theoretical work on optimal network expansion, there does not seem to be any commercial software with this capability. The industry could benefit significantly from practical software that performed true network expansion planning that considered economies of scale. Building blocks for this software would be better techniques for characterizing transmission system capability such as discussed in (EPRI 1991).

Uncertainties in future load growth provide special challenges because of the risk associated with taking advantage of economies of scale. One way to ameliorate the risk due to future uncertainties in network expansion is to delay commitments to new incremental transmission by temporarily increasing transmission capacity through technology such as 'Flexible AC Transmission' (FACTS) (EPRI 1990). FACTS technology can be used to temporarily increase the transfer ratings of existing lines. Its advantages include:

1. it can be relocated in a system as requirements change, and,
2. it can be added in relatively small increments without sacrificing economies of scale.

Temporary needs for increased transfer capacity can be accommodated without large construction; instead, only the costs of:

1. *rental* of FACTS equipment matched to the increased needs,
2. capital for minor facilities to connect the FACTS equipment to the network, and,
3. higher losses due to operation of, for example, phase shifters (Hayward et al. 1991), need be incurred.

If need for increased transmission capacity is then established in the long-run, transmission line construction can be undertaken and the FACTS equipment moved to another line. Using FACTS to temporarily increase transfer capacities can reduce the risks of uncertain futures by delaying commitment to large capital-intensive projects.

Widespread incorporation of FACTS technology into the transmission system would significantly complicate the operation of the system. However, under this proposal, FACTS would be used judiciously and not as a long-term replacement for transmission construction. Its function would be to smooth out the lumpiness of transmission construction and therefore lessen the risk burden imposed by the economies of scale of transmission construction: “[t]he operating procedures for alleviating constrained conditions should not be viewed as permanent, long-term solutions, but as temporary expedients until system reinforcements can be provided or system conditions change” (Hayward 1991).

In conclusion, we observe that significant progress is possible in regulatory treatment of transmission through use of proposals and ideas that are currently being tested. Better software models would benefit the industry significantly. Only with such developments can the potential benefits of increased competition in generation be achieved.

## **Acknowledgements**

**This work was funded by the Assistant Secretary for Conservation and Renewable Energy, Office of Utility Technologies, Office of Energy Management of the U.S. Department of Energy under Contract No. DE-AC03-76SF00098. We would like to thank Dr. Robert San Martin, Jake Kaminsky, Diane Pirkey and Ken Schafer of DOE for their support. We have received review, comment and supporting documentation from a number of individuals. We list them and absolve them of all responsibility for the contents of this document: Chuck Goldman and Joe Eto, LBL; Michael Arny, Public Service Commission of Wisconsin; David Cory, Pacificorp; Michael Dworkin and Rick Weston, Vermont Public Service Board; Steve Henderson, FERC; Paul Johnson, Consumers Power; Jim Kritikson, Southern California Edison; Jim Lahtinen, Duquesne Light; Mike Lee, Montana Public Service Commission; Jim McCluskey, California Energy Commission; Roger Naill, AES; Mike Riordan, Boston University; John Scadding and Jim Scarf, California Public Utilities Commission; Tom Stanton, Michigan Public Service Commission; Nancy Sutley, National Independent Energy Producers; and Tom Wies, Vermont Electric Company. Finally, we thank Ellen Hodges for technical editing, graphics and report production.**



## References

- Alahydoian, R. and G. Comnes 1990, "An Assessment of QF Transmission Needs: Past Problems and Future Demand," Staff Research Paper, Division of Strategic Planning, California Public Utilities Commission, September.
- Army, M. and D. Dasho 1988, "Transmission Planning: The Wisconsin Experience," *Proceedings of the Sixth National Association of Regulatory Utility Commissioners Biennial Regulatory Information Conference*, Volume 2, Pages 773-805.
- Army, M. and B. James 1990, "State Transmission Planning and Federal Power Policy: Turf War to Alliance?" *The Electricity Journal*, 3(3):40—49, April.
- Army, M. and B. James 1991, "New Attitudes Towards Transmission - Wisconsin Style," *Public Utility Fortnightly*, Vol. 128 No. 6, September 15.
- Army, M. 1992, "The Wisconsin Transmission Interface Study: A Model For Regional Electric Transmission Planning," *The Electricity Journal*, Volume 5, Number 5, June.
- Averch, H. and L. Johnson 1962, "Behavior of the Firm Under Regulatory Constraint," *American Economic Review*, 52(5):1053—1069.
- Baron, D. and D. Besanko 1984a, "Regulation and Information in a Continuing Relationship," *Information Economics and Policy*, 1:267—302.
- Baron, D. and D. Besanko 1984b, "Regulation, Asymmetric Information, and Auditing," *The Rand Journal of Economics*, 15(4):447—470.
- Baumol, W., J. Panzar and R. Willig 1988, *Contestable Markets and the Theory of Industrial Structure*, Revised Edition, Harcourt Brace Jovanovich, San Diego CA.
- Bean, J. and R. Smith 1984, "Conditions for the Existence of Planning Horizons," *Mathematics of Operations Research*, 9(3):391—401, August.
- Berg, S. and J. Tschirhart 1988, *Natural Monopoly Regulation: Principles and Practice*, Cambridge University Press, Cambridge and New York.
- Bergen, A. 1986, *Power Systems Analysis*, Prentice-Hall.
- Boffey, T. and J. Green 1983, "Design of Electricity Supply Networks," *Discrete Applied Mathematics*, 5:25—38.

- Brown, S. and D. Sibley 1986, *The Theory of Public Utility Pricing*, Cambridge University Press, Cambridge and New York.**
- California Energy Commission (CEC) 1990, "Municipal Utility Transmission Survey: Summary and Analysis," September.**
- California Energy Commission (CEC) 1991, "Transmission System and Right of Way Planning for the 1990's and Beyond: A Response to SB 2431 (Garamendi)," Staff Draft, January.**
- California Energy Company, Inc. (CECI) 1990, "Comments of California Energy Company, Inc. on Utility Transmission Services for Non-utility Power Producers," Response to the California Public Utilities Commission's Order Instituting Investigation I.90-09-050, November 30.**
- California Public Utilities Commission (CPUC) 1987, "Second Report to the California Legislature on Implementation of Assembly Bill 475 (1985): Production Cost Computer Models Used by California Utilities."**
- California Public Utilities Commission (CPUC) 1988, Decision 88-12-030, the Devers-Palo Verde Decision, December 9.**
- California Public Utilities Commission (CPUC) 1990a, Decision 90-09-059, the Kramer-Victor Decision, September 12.**
- California Public Utilities Commission (CPUC) 1990b, Decision 90-11-052, Opinion Adopting Rules Regarding Access to Computer Models, November 21.**
- California Public Utilities Commission (CPUC) 1991, Decision 91-04-071, the California-Oregon Transmission Project Decision, April 24.**
- Casazza, J. 1991, "Transmission Access and the Public Welfare," Presented at 'Ideas and Innovations—Accessing Our Energy Future,' Indianapolis IN, CSA Energy Consultants, October 31.**
- Cleveland Public Power (CPP) 1991, "Public Power System Improvement First Mortgage Revenue Bonds, Series 1991," Preliminary Official Statement, September 6.**
- Consolidated Edison Company 1990, "Request for Proposals for Supply Side and Demand Side Resources RFP# 90-1," New York, NY 10003.**
- Consumers Power (CP) 1990a, Letter of Allen C. Erickson, Executive Engineer, Wholesale Power Transactions and Planning Department, Consumers Power to Mr. Robert Dyer, Midland Cogeneration Venture, April 10.**

- Consumers Power (CP) 1990b, "Interconnection Agreement Between Consumers Power Company and PSI Energy, Inc.," December 1.
- Consumers Power (CP) 1992a, "Application and Request for Determinations, In the Matter of the Application of Consumers Power Company for (i) accounting and ratemaking treatment, including an electric rate increase, effective upon commercial operation, and (ii) a determination of public necessity for a proposed 345-kV transmission line and interconnection between Consumers Power Company and PSI Energy, Inc.," Case No. U-10059, January 31.
- Consumers Power (CP) 1992b, "1991 Annual Report," March 6.
- Consumers Power (CP) 1993c, Reply Brief in Case No. U-10059 and U-10061, 1992.
- Corey, D. 1991, Telephone conversation with David Corey, Manager, Power System Wheeling Policy, PacifiCorp Electric Operations, August 9.
- Crew, M. and P. Kleindorfer 1986, *The Economics of Public Utility Regulation*, MIT Press.
- David, P. 1987, "Some New Standards for the Economics of Standardization in the Information Age," in Partha Dasgupta and Paul Stoneman, editors, *Economic Policy and Technological Performance*, Cambridge University Press, Cambridge and New York.
- Decision Focus Incorporated (DFI) 1990, "The Economics of New Transmission Versus Other Alternatives in Meeting California Electricity Demands, Phase II," Prepared for the California Energy Commission by Decision Focus, Inc., Los Altos CA, October.
- Division of Ratepayer Advocates (DRA) 1990, California Public Utilities Commission, "Report on the Cost-Effectiveness of the CPC&N Applications Filed By Southern California Edison Company, San Diego Gas & Electric Company, Pacific Gas & Electric Company for the California-Oregon Transmission Project," Volume I, November.
- Duquesne Light Company (DLC) 1990, White Paper, December 3.
- Duquesne Light Company (DLC) 1991, "Description of Duquesne Light Company's plans to make 500 MW of long term transmission service available to wholesale customers," Leaflet available from James A. Lahtinen, Manager, Transmission Services, Duquesne Light, Pittsburgh PA.
- EDAW, Inc. 1990, "Transmission Line Planning, Permitting and Development in California: Case Studies of Environmental Consequences," Prepared for Decision Focus, Inc. and the California Energy Commission, Preliminary Draft, October 10.

Einhorn, M. 1996, "Electricity Wheeling and Incentive Regulation," *Journal of Regulatory Economics*, 2:173—189.

Electric Power Research Institute (EPRI) 1986, *TAG—Technical Assessment Guide*, Volume 1: Electricity Supply—1986, Document EPRI P-4463SR, EPRI, Palo Alto CA, December.

Electric Power Research Institute (EPRI) 1990, *Flexible ac Transmission Systems (FACTS): Scoping Study, Volume 1*, Part 1: Analytical Studies, Document EPRI EL-6943, EPRI, Palo Alto CA, August.

Electric Power Research Institute (EPRI) 1991, *Simultaneous Transfer Capability: Direction for Software Development*, Final Report, Document EPRI EL-7351, EPRI, Palo Alto CA, August.

Federal Energy Regulatory Commission (FERC) 1987, "Utah Power & Light Company, PacifiCorp and PC/UP&L Merging Corporation, Docket No. EC88-2-000, Order Establishing Hearing Procedures, etc," 41 FERC ¶ 61,283, December.

Federal Energy Regulatory Commission (FERC) 1988a, "Utah Power & Light Company, PacifiCorp and PC/UP&L Merging Corporation, Docket No. EC88-2-000, Initial Decision," 43 FERC ¶ 63,030, June.

Federal Energy Regulatory Commission (FERC) 1988b, "Utah Power & Light Company, PacifiCorp and PC/UP&L Merging Corporation, Docket No. EC88-2-000, Opinion No. 318," 45 FERC ¶ 61,095, October.

Federal Energy Regulatory Commission (FERC) 1989, "The Transmission Task Force's Report to the Commission. Electricity Transmission: Realities, Theory and Policy Alternatives," October.

Federal Energy Regulatory Commission (FERC) 1990, "Pacific Power and Light Company, Docket No. ER89-493-000, Utah Power & Light Company, Docket No. ER89-494-000, Pacific Power & Light Company, Utah Power & Light Company, PC/UP&L Merging Corporation, Docket No. EC88-2-004, Order Noting and Granting Interventions, etc," 51 FERC ¶ 61,295, June.

Federal Energy Regulatory Commission (FERC) 1991a, "Western Systems Power Pool, Docket No. ER87-97-000, Order Noting and Granting Interventions, Denying Request for Waiver, Accepting Answers, And Conditionally Accepting Rates as Modified Without Suspension or Hearing," Issued April 23.

Federal Energy Regulatory Commission (FERC) 1991b, "Western Systems Power Pool, Docket No. ER87-97-001, Order Granting In Part and Denying In Part Requests for Rehearing and Clarification, and Denying Requests for Oral Argument," Issued June 27.

- Florida Power Corporation (FPC) 1991, "Integrated Resource Study," Petersburg FL, August.
- Flynn and Associates 1990, "Transmission Line Planning and Siting: The State's Role," Prepared for the California Energy Commission by Flynn and Associates, Redwood City CA, May 1.
- Green, E. 1984, "On the Difficulty of Eliciting Summary Information," *Journal of Economic Theory*, 32:228—245.
- Green, R. 1990, "How to Regulate a Network Utility With a Monopoly Over Transmission But Competition in Supply," Manuscript, Department of Applied Economics, Austin Robinson Building, Sidgwick Avenue, Cambridge CB3 9DE, United Kingdom, 25 May 1990, Revised 30 July.
- Green, J. and J. Laffont 1977, "Characterization of Satisfactory Mechanisms for the Revelation of Preferences for Public Goods," *Econometrica*, 45(2):427—438, March.
- Green, J. and J. Laffont 1986, "Partially Verifiable Information and Mechanism Design," *Review of Economic Studies*, LIII:447—456.
- Gribik, P., D. Shirmohammadi, S. Hao and C. Thomas 1990, "Optimal Power Flow Sensitivity Analysis," *IEEE Transactions on Power Systems*, 5(3):969—976, August.
- Gross, G. 1991, "Western Systems Power Pool," Presentation, Pacific Gas & Electric Company, San Francisco CA.
- Groves, T. and J. Ledyard 1987, "Incentive Compatibility Since 1972," in Theodore Groves, Roy Radner, and Stanley Reiter, *Information Incentives and Economic Mechanisms: Essays in Honor of Leonid Hurwicz*, Chapter 2, pp48—111, University of Minnesota Press.
- Harris, M. and R. Townsend 1981, "Resource Allocation Under Asymmetric Information," *Econometrica*, 49(1):33—64, January.
- Harvego, L. 1990, In *The Transmission Symposium, Proceedings and Papers*, pp 197—206, Public Utilities Reports, Inc, The Management Exchange, New York, NY.
- Hayward, D. et al. 1991, "Operating Problems with Parallel Flows," *IEEE Transactions on Power Systems*, 6(3):1024—1034, August.
- Hobbs, B. and K. Kelly 1990, "Using Game Theory to Analyze Electric Transmission Pricing Policies in the United States," Manuscript, October.

- Hogan, W. 1992, "Prepared Direct Testimony of William W. Hogan, Duquesne Light Transmission Proposal."
- Independent Power Report (IPR) 1991, "SMUD Selections Include Four Local Cogeneration Units Financed by SMUD," *Independent Power Report*, pp1—3, July 19.
- Jurewitz, J. 1990, "When Avoided Costs Become an Endogenous Variable: Emerging Problems in California," Paper presented to Third Annual Western Conference Advanced Workshop in Regulation and Public Utility Economics, July 11.
- Johnson, P. 1992, "Direct Testimony of Paul F. Johnson in the Matter of the Application of Consumers Power Company for (i) accounting and ratemaking treatment, including an electric rate increase, effective upon commercial operation, and (ii) a determination of public necessity for a proposed 345-kV transmission line and interconnection between Consumers Power Company and PSI Energy, Inc.," Case No. U-10059, April 10.
- Kahn, E. 1991 "Risk Allocation in Independent Power Contracts," LBL-30065.
- Kahn, E. and C. Goldman 1991, "The Role of Competitive Forces in Integrated Resource Planning," LBL-30982, Applied Science Division, Lawrence Berkeley Laboratory, University of California, Berkeley CA, October.
- Kahn, E., S. Stoff, C. Marnay and D. Berman, "Contracts for Dispatchable Power: Economic Implications for the Competitive Bidding Market," Applied Science Division, Lawrence Berkeley Laboratory, LBL-29447, Berkeley CA, October.
- Kelly, K, S. Henderson, P. Nagler and M. Eifert 1987, "Some Economic Principles for Pricing Wheeled Power," The National Regulatory Research Institute, Columbus OH, August.
- Knight, F. 1964, *Risk, Uncertainty and Profit*, A. Kelley, New York.
- Large Public Power Council (LPPC), "Proposal for a National Voluntary Approach to Promote and Co-ordinate Increased Electric Transmission Access," 1990, reproduced in *The Transmission Symposium: Proceedings and Papers 1990*, pp84—96, Public Utilities Reports.
- Larson, R. and J. Casti 1978, *Principles of Dynamic Programming, Part I: Basic Analytic and Computational Methods*, Marcel Dekker, Inc., New York.
- Lawler, E. 1976, *Combinatorial Optimization: Networks and Matroids*, Holt, Rinehart and Winston, New York.
- Lieberman, L. 1992 "The Impact of Procurement Regime on the Price Paid for Independent Generation," Working paper, Department of Economics, Stanford University.

- Los Angeles Department of Water and Power (LADWP) 1990, "Request for Proposals 1990 Solicitation: Volume 1: Generation Resources," June.
- Markey, E. 1991, "A Bill to Amend the Federal Power Act," 102nd Congress, 1st Session, HR2224, May 2.
- Mays, S. 1990, "Direct Examination in the San Diego Gas & Electric/SCE Merger Case," CPUC Application No. 88-12-035, June.
- Michigan Public Power Agency (MPPA) 1991, Letter of Gary L. Zimmerman, General Manager, Michigan Public Power Agency to Mr. Frederick Buckman, President, Consumers Power Company, November 26.
- Michigan Public Service Commission (MPSC) 1992, Staff Initial Brief in Case No. U-10059 and U-10061, 1992.
- Midland Cogeneration Venture Limited Partnership (MCVLP) 1991, "Prospectus Supplement," November 1.
- Milbourne, T. 1992, "Prepared Direct Testimony of H. Thomas Milbourne, Duquesne Light Transmission Proposal."
- Morris, C. and K. Dozier 1991, "Transmission Reform Gaining in House; While Members Recess, Staff Drafts," *The Electricity Journal*, 4(7):7-8, August/September.
- Munts, M. 1991, "The Changing Regulatory Environment," Presented at the International Energy Conference on Demand-Side Management and Least-Cost Planning, Copenhagen, Denmark, October 23-24.
- National Association of Regulatory Utility Commissioners (NARUC) 1990, "Survey of the National Transmission System," Prepared by the National Association of Regulatory Utility Commissioners, Staff Subcommittee on Electricity Transmission Working Group, July 16, 1990, Revised August 30.
- National Regulatory Research Institute (NRRI) 1987, *Some Economic Principles for Pricing Wheeled Power*, Report NRRI-87-7, NRRI, Columbus OH, August.
- Nevada Power Company (NPC) 1991, "1991 Resource Plan and Action Plan, Volume II," Las Vegas NV.
- Niagara Mohawk Power Corporation (NMPC) 1991, Corporate Planning Department, "1991 Integrated Electric Resource Plan," Syracuse NY, September.

- Nuclear Regulatory Commission (NRC) 1981, "Pacific Gas & Electric Company, Docket No. 50-275, Diablo Canyon Nuclear Plant, Unit 1, Facility Operating License," License No. DPR-76.
- Nuclear Regulatory Commission Atomic Safety and Licensing Appeal Board 1979, "In the Matter of the Toledo Edison Company and the Cleveland Electric Illuminating Company (Davis-Besse Nuclear Power Station, Units 1, 2 and 3), The Cleveland Electric Illuminating Company et al. (Perry Nuclear Power Plant, Units 1 and 2)," 10 NRC 265 (1979), September 6.
- Orans, R. 1989, "Area Specific Marginal Costing for Electric Utilities: A Case Study of Transmission and Distribution Costs," Ph.D. Dissertation, Civil Engineering Department, Stanford University.
- Orans, R. 1991, "Transmission and Distribution Least Cost Planning: Challenges and Innovations," Unpublished Manuscript.
- Osborn, J. 1992, "Direct Testimony of John D. Osborn in the Matter of the Application of Consumers Power Company for (i) accounting and ratemaking treatment, including an electric rate increase, effective upon commercial operation, and (ii) a determination of public necessity for a proposed 345-kV transmission line and interconnection between Consumers Power Company and PSI Energy, Inc.," Case No. U-10059, April 10.
- O'Sullivan, J. 1991, "Legal and Regulatory Issues," *The Transmission Symposium: Proceedings and Papers 1990*, pp155—158, Public Utilities Reports.
- Pacific Gas and Electric (PG&E) 1991a, "PG&E's Transmission Planning Test Cases," Presented at the CPUC Transmission Access Workshop, August 22.
- Pacific Gas and Electric (PG&E) 1991b, "LOCATION Model," Presented at the CPUC Transmission Access Workshop, September 12.
- PacifiCorp 1991a, "FERC Electric Tariff, Original Volume No. 5 of PacifiCorp Electric Operations filed with Federal Energy Regulatory Commission," May 1989 with various revisions up to June.
- PacifiCorp 1991b, "Final Version of Pacificorp Electric Operations Presentation," Presented at the CPUC Transmission Access Workshop, August 14.
- Pennsylvania Public Utility Commission (PaPUC) 1992, Order in Docket Nos. G-900240, P-900485, P-910502, C-913375, P-910502C001, 1992.
- Public Service Commission of Wisconsin (PSCW) 1989, "Advance Plan 5 Order," Docket 05-EP-5.



- Public Service Commission of Wisconsin (PSCW) 1991a, "Advance Plan 6 Filing," Docket 05-EP-6, March 1.
- Public Service Commission of Wisconsin (PSCW) 1991b, "Staff Issue Paper: Externalities," October 1.
- Public Utilities Commission of Texas (PUCT) 1990, "Final Report From the Task Force on QF Wheeling Issues," August.
- Roukos, N. and M. Caramanis 1988, "WRATES User's Manual," Meta Systems, Inc., Cambridge MA, August.
- Rupp, S. 1990a, "Report of Steven S. Rupp on System Benefits of the Proposed Kramer-Victor 220 kV Transmission Line," attached to Rebuttal Testimony of Steven S. Rupp before the California Public Utilities Commission, Application No. 89-03-026, Sierra Energy and Risk Assessment, Roseville CA, February 20.
- Rupp, S. 1990b, "Surrebuttal Testimony of Steven S. Rupp before the California Public Utilities Commission, Application No. 89-03-026," Sierra Energy and Risk Assessment, Roseville CA, March 15.
- San Diego Gas & Electric (SDG&E) 1991, "Description of San Diego Gas & Electric Company's Transmission Planning Examples," Presented at the CPUC Transmission Access Workshop, August 21.
- Santos, A., P. Franca and A. Said 1989, "An Optimization Model for Long-Range Transmission Expansion Planning," *IEEE Transactions on Power Systems*, 4(1):94—101, February.
- Scherer, C. 1976, "Estimating peak and off-peak marginal costs for an electric power system: an *ex ante* approach," *The Bell Journal of Economics*, 7(2):575—601, Autumn.
- Schoonyan, G., J. Kaiser, W. Schauer and S. Rupp 1991, "Regional Model Assesses Economy Energy Purchases," *IEEE Computer Applications in Power*, 4(3):32—37, July.
- Schori, J. 1991, "Models for Control and Operation of the U.S. Transmission Grid," *The Transmission Symposium: Proceedings and Papers 1990*, pp80—83, Public Utilities Reports.
- Schweppe, F., M. Caramanis, R. Tabors and R. Bohn 1988, *Spot Pricing of Electricity*, Kluwer Academic, Boston MA.
- Shaffer, B., et al. 1992, "CPCO-PSI Transmission Line: Shaffer Class Plaintiffs' Initial Pleading: Complaint, Application & Petition," Case No. U-10061, Michigan Public Service Commission, February 3.

- Shirmohammadi, D. and C. Thomas 1991, "Valuation of the Transmission Impact in a Resource Bidding Process" *IEEE Transactions on Power Systems*, 6(1):316—323, February.
- Shirmohammadi, D., C. Rajagopalan, E. Alward and C. Thomas 1991, "Cost of Transmission Transactions: An Introduction," *IEEE Transactions on Power Systems*, 6(4):1546—1560, November.
- Sierra Energy and Risk Assessment (SERA) 1991a, "SERAM Surplus Energy Resource Assessment Model," Company Flier, Sierra Energy and Risk Assessment, Roseville CA.
- Sierra Energy and Risk Assessment (SERA) 1991b, "Key Elements of SERAM," Company Document, Sierra Energy and Risk Assessment, Roseville CA.
- Sierra Pacific Power Company (SPPC) 1991, "Transmission Planning Case Studies," Presented at the CPUC Transmission Access Workshop, August 14.
- Singh, N. and D. Wittman 1988, "Incentive Compatibility and Partial Verification," Working Paper #173, Organized Research Activity in Applied Economics/International Economics, Department of Economics, University of California, Santa Cruz CA, April.
- Southern California Edison (SCE) 1991, "Description of Southern California Edison Company's Transmission Planning Examples," Presented at the CPUC Transmission Access Workshop, August 13.
- Stalon, C. 1990a, "Transmission—the Heart of the Issue," *The Electricity Journal*, 3(3):14—23, April.
- Stalon, C. 1990b, "The Significance of the FERC's Transmission Task Force Report in the Evolution of the Electric Industry," Presented to the Electric Policy Symposium, The Center for Law and Economic Studies, Columbia School of Law, New York, April 7.
- Staschus, K., et al. 1991, "A Multi-Attribute Evaluation Framework for Electric Resource Acquisition in California," *Electrical Power and Energy Conversion*, 13(2):73—80, April.
- Stalon, C. 1991, "Federal-State Joint Mechanisms for Regulating Electric Utilities," Presented to the National Conference on Regionalism in Electric Utility Regulation, Washington DC, October 1.
- Stevenson, W. 1982, *Elements of Power System Analysis*, McGraw-Hill.
- Stoft, S. and E. Kahn 1991, "Auction Markets for Dispatchable Power: How to Score the Bids," *Journal of Regulatory Economics* 3(3):275—286.

- Stoll, H. 1989, *Least-Cost Electric Utility Planning*, John Wiley and Sons, Inc., New York NY.
- Strategic Decisions Group (SDG) 1991, "SDG Comments on FERC Order April 23, 1991, Docket No. ER91-195-000," Prepared by T. Keelin and S. Galatis, Menlo Park CA, May 22.
- Tauzin, B. 1991, "A Bill to Facilitate Powerplant Ownership by the able to build and operate electric powerplants at the lowest reasonable cost," 102nd Congress, 1st Session, HR2825.
- U.S. Congress, Office of Technology Assessment (USOTA) 1989, *Electric Power Wheeling and Dealing: Technological Considerations for Increasing Competition*, OTA-E-409, Washington DC, May.
- United States Department of Energy (USDOE) 1988, *Final Environmental Impact Statement/Environmental Impact Report for the California-Oregon Transmission Project and the Los Banos-Gates Transmission Project*, Volume 1, Publication DOE/EIS-0128, January.
- United States Department of Energy (USDOE) 1991/1992, *National Energy Strategy*, "Technical Annex 3: Electricity Transmission Access," Publication DOE/S-0085P, First Edition.
- United States District Court (USDC) 1989, N.D. California, "United States of America, acting By and Through the Western Area Power Administration, Plaintiff, v. Pacific Gas and Electric Company, et al.," No. C-88-1600-WWS, 714 Federal Supplement 1039 (N.D. Cal. 1989), June 8.
- United States Securities and Exchange Commission (USSEC) 1991, "Form 10-K, Centerior Energy Corporation, The Cleveland Electric Illuminating Company, The Toledo Edison Company," for the fiscal year ended December 31, 1990, filed in 1991.
- Varian, H. 1984, *Microeconomic Analysis*, Norton, New York NY.
- Verhey, J. 1989a, "Testimony of James F. Verhey on Behalf of Luz International Limited Regarding Cost Responsibility for Interconnection and Integration Facilities, before the California Public Utilities Commission, Application No. 89-03-026," Sierra Energy and Risk Assessment, Roseville CA, November 22.
- Verhey, J. 1989b, "Supplemental Testimony of James F. Verhey In Support of Application for Certificate of Public Convenience and Necessity, before the California Public Utilities Commission, Application No. 89-03-026," Sierra Energy and Risk Assessment, Roseville CA, December 8.

- Verhey, J. 1990, "Surrebuttal Testimony of James F. Verhey, before the California Public Utilities Commission, Application No. 89-03-026," Sierra Energy and Risk Assessment, Roseville CA, March 15.
- Vermont Electric Power Company, Inc. (VELCO) 1957, "Organization History and Purposes," Rutland VT.
- Vermont Electric Power Company, Inc. (VELCO) 1981 "Transmission Agreement," Rutland.
- Vermont Electric Power Company, Inc. (VELCO) 1987, "Long-Range State-Wide Bulk Power Transmission Expansion for Vermont," Rutland VT, February.
- Vermont Electric Power Company, Inc. (VELCO) 1989, "A Transmission Company," Rutland VT.
- Villasana, R. 1984, *Transmission Network Planning Using Linear and Linear Mixed Integer Programming*, Ph.D. thesis, Rensselaer Polytechnic Institute.
- Weatherwax, R., et al. 1987a, "Second Devers to Palo Verde 500 kV AC Transmission Line Final Need and Alternatives Report Volume I," Sierra Energy and Risk Assessment, Roseville CA, April.
- Weatherwax, R., et al. 1987b, "Second Devers to Palo Verde 500 kV AC Transmission Line Revised Final Supplemental Report on Need and Alternatives," Sierra Energy and Risk Assessment, Roseville CA, September.
- Weatherwax, R., et al. 1988, "Second Devers to Palo Verde 500 kV AC Transmission Line Second Supplemental Report on Need and Alternatives," Sierra Energy and Risk Assessment, Roseville CA, September 9.
- Western Association for Transmission Systems Coordination (WATSCO) 1991, "Draft Bylaws".
- Western Systems Power Pool (WSPP) 1991, "Exhibit C, Long-Term Firm Transmission Service Principles," Application for permanent WSPP agreement, Docket ER91-195-000, January 2.

## **Appendix**

# **The Economics of Information and Transmission Regulation**

### **A.1 Overview**

In this appendix we analyze economic issues such as information asymmetries economies of scale that were essentially absent from the theory, practice, and software described in Chapter 5. In Section A.2, we first address the fundamental need for planning and regulatory oversight in transmission. In Section A.3, we review some of the economic literature on wheeling and evaluate treatment of these issues. In Section A.4, we examine the literature on information asymmetry. In Section A.5, we investigate the trade-off between potential gains from IPP competition in the generation sector and potential coordination losses due to missed opportunities to exploit economies of scale in transmission construction.

### **A.2 Market Forces and Natural Monopoly in the Electric System**

In a classical marketplace, decentralized decisions are made independently by participants. Under suitable conditions on the structure of the economy, classical economies can be shown to achieve welfare optimal allocations of resources without intervention by regulation and without deliberate coordination between participants (Varian 1984).

In contrast, the electricity system is heavily regulated and we saw in Chapter 5 that sophisticated centralized models are used to analyze transmission operation and planning. The standard justification for such regulation is that the industry is a natural monopoly. We will try to offer a more detailed explanation for the possibility of market failure in the electric system, while noting carefully the arenas in which market forces can be expected to function well. We will consider explicitly some of the issues that we raised in Chapter 2.

Various theoretical work has been devoted to the notion that natural monopolies will not achieve welfare optimal investments and allocations of resources in the absence of regulation (Berg and Tschirhart 1988, Brown and Sibley 1986, Crew and Kleindorfer 1986). The first question to be asked, therefore, is whether the electric system and transmission, in particular, is a natural monopoly.

Recently, the economies of scale of generation have been essentially exhausted and it has been asserted that the generation sector is no longer a natural monopoly. To the extent that different sectors of the electric system can be analyzed separately, it is then possible to consider a generation 'market,' while also treating transmission and distribution as regulated monopoly services (Green 1990). As we have argued, there remains significant economies of scale in

transmission, which in standard natural monopoly theory would justify regulation even in the absence of regulation in the generation sector.

Unfortunately, there is a weakness in typical applications of natural monopoly theory: it does not consider the possibility that a capital-intensive facility, experiencing economies of scale, can be owned jointly by competitors. That is, while economies of scale are a technological characteristic, ownership, and hence monopoly power, is an entirely contractual characteristic.

Although the practicality of joint ownership may be debatable in, for example, a traditional factory, in network technologies, such as telecommunications and electric transmission, joint ownership is becoming increasingly common at the inter-regional level. Consider, for example, undersea cables and satellites, which are often built, owned, and operated as joint ventures between international partners.

Stalon (Stalon 1991b) goes further and points out that individual lines should not be considered in isolation, but that instead the three regional transmission networks in the United State are the three relevant 'facilities.' Under this view, each facility is already jointly owned, although most individual lines are owned and operated by individual utilities. While agreeing with Stalon, in principle, we will focus on the joint ownership of individual lines by multiple parties.

The Duquesne/GPU joint venture and the California-Oregon Transmission Project (COTP) are examples of large jointly owned transmission projects with significant economies of scale in construction. The owners could potentially compete to sell transmission service on the lines to third parties: as noted in Section 4.5, an auction will be used to allocate one-third of the capacity of the Duquesne/GPU line and a secondary market may arise for this capacity.

With such joint ownership, the natural monopoly status of transmission becomes moot. Although one 1500 MW line is cheaper than three 500 MW lines, it is not clear that single ownership offers significant operational efficiency advantages over multiple ownership. We assert that the potential for competition in a secondary transmission market may invalidate many of the basic conclusions of natural monopoly theory applied to operation of transmission facilities, if joint ownership of large facilities is encouraged by market structure and regulation. The effect of secondary markets is discussed in (FERC 1989).

In contrast:

- the economies of scale and lumpiness of transmission construction, and,
- economies of scope and externalities of transmission operation,

dictate that *construction* decisions be coordinated to achieve optimal transmission planning. Furthermore, there is potential for unsustainability in construction. While a pricing mechanism—perhaps with special treatment for economies of scope and externalities—might be used to allocate capacity between transmission consumers once the capacity is built, the planning

and design of a large joint venture requires sophisticated coordinated planning. We have argued that the operations and planning must also be jointly optimized.

In contrast, we have seen in Chapter 5 that the planning tools ignore lumpiness, economies of scale, and most externalities. We have argued that these issues are *the* basic reason for adopting sophisticated centralized planning models over decentralized planning, yet these issues are missing from these models. This is not to say that the software models are not themselves sophisticated, but instead that the fundamental problems are difficult to solve. It is clear that these models could be significantly improved through the incorporation of these features.

### **A.3 Survey of Economics Literature on Wheeling**

The first paper we consider is Hobbs and Kelly (1990), which focuses on non-firm transmission markets. Their work indicates that long-term strategic decisions concerning construction may defeat a policy, such as market pricing of transmission access, that encourages short-run efficiency. The basic reason is that the monopoly wheeler may choke off demand by limiting construction: the issue here is the interplay of short-term transmission access and long-term transmission planning. As we have remarked above, the possibility of joint ownership of transmission facilities may ameliorate this problem.

Hobbs and Kelly then observe that if the 'cost' of encouraging wheeling is remuneration for wheeling above cost, then this cost may be much smaller than the gains of trade (Hobbs and Kelly 1990). They then propose that a 'split-savings' rule may be adequate for this purpose. This rule allocates to the wheeler a proportion of the gains of trade, based on the difference in, for example, short-run marginal production costs between the seller and wheeler and between the wheeler and buyer. Such a rule will encourage efficient utilization of the system, but *also* encourages efficient planning, Hobbs and Kelly argue.

If there are transmission limits; however, consideration of only the marginal costs of generation may not efficiently allocate scarce transmission capacity. In other words, some consideration must be given to transmission congestion. Einhorn (1990) argues that short-run marginal-costs are difficult for regulators, buyers, and sellers to verify if they include congestion costs. That is, a split savings rule, including transmission congestion costs, would be difficult to implement: while split savings would encourage transmission access if protagonists reveal their true marginal costs, in practice the information asymmetry allows considerable gaming and loss of welfare, particularly if regulatory intervention is involved. We have argued that when competing protagonists have approximately equal technical expertise, it may be possible to assert that competing analyses will discipline the revelation of marginal-costs in a market.

Einhorn instead proposes that regulators "specify two prices, a fixed price for reserved wheeling demands and a price ceiling for nonfirm...Subject to [this ceiling], the wheeler may design one nonuniform price schedule for nonfirm wheeling. Four advantages consequently arise. First, the possibility of long-run profits may afford wheelers the economic incentives to open up their

transmission network and provide wheeling service...Second, regulators do not need to establish prices based on short-run marginal costs or to attempt to ensure that wheelers minimize costs...Third, wheelers do not modify their price schedule to meet instantaneous variations in the buyer's demand parameter...Finally, a profit-maximizing wheeler will have incentives to size transmission capacity as efficiently as would a welfare-maximizing wheeler with the same degree of price flexibility" (Einhorn 1990).

Einhorn's analysis is attractive in that it considers the information issues in the context of wheeling and derives a policy that requires minimal regulatory oversight. Unfortunately, Einhorn's model suffers from several drawbacks. They are the following:

1. The model of demand for wheeling is that at any time  $t$ , the demand for wheeling is a random parameter  $i(t)$  drawn from a distribution  $F$  that is independent of  $t$ . However, it seems that a more realistic model would have  $F$  parametrized by  $t$ : in fact, a completely deterministic model, with  $i$  a deterministic function of  $t$ , might be a much better description of actual diurnal and weekly demand for wheeling than Einhorn's unrealistic model, in which the time of the peak and off-peak demands are uniformly distributed over time.
2. The analysis derives a non-uniform price schedule for a single wheeling customer and does not indicate how to generalize to multiple customers. Secondary markets might defeat non-uniform prices.
3. In common with most of the work on information asymmetry, and to be discussed in more detail below in Section A.4, Einhorn assumes away uncertainty (as opposed to risk (Knight 1964)), by positing known probability distributions.
4. In common with most of the pricing literature, the analysis ignores lumpiness and economies of scale in transmission construction.

It may be possible to remove some of these difficulties by modifying the analysis; however, the assumptions seem to be at least as difficult to satisfy as the assumption of approximately truthful revelation of marginal-costs required for operation of split savings rules.

We now turn to a paper by Green (1990). This work is interesting because it reflects on the Federal Energy Regulatory Commission (FERC) Transmission Task Force's commentary (FERC 1989) about deregulating the generation market, while keeping transmission regulated. Green warns that regulating one or the other of the wheeling price or the final electricity price may lead to lower welfare than a 'regulatory bargain,' whereby a utility agrees to curb its prices in one market in return for laxer regulation in the other. The results depend heavily on the structure of the cost functions and we can gain no firm conclusions without further empirical studies.



## **A.4 Survey of Economics Literature on Information Asymmetries**

We have observed that approaches to transmission planning such as the Wisconsin Advance Plan process would produce desirable results *if* the technical information possessed by the various protagonists was public knowledge or, at least publicly verifiable. We have noted that transmission pricing access rules such as split savings would also have desirable characteristics if marginal costs were truthfully revealed. Software tools, such as the ones described in Sections 6.4 and 6.5, implicitly assume that all the necessary information is available and accurate. The levels of welfare calculated by these methods can only be achieved in the absence of information asymmetries.

In contrast, because the protagonists in the transmission system possess private, essentially unverifiable, information it is their prerogative to misinform, so long as the misinformation is consistent with any publicly known information. In general, we can only expect truthful response if truth is in the best interest of the respondent. For example, in some circumstances, competitive discipline can be used to reveal this information. A policy that induces truthful behavior is called 'incentive compatible' (Green and Laffont 1977, Groves and Ledyard 1987). Such a policy will generally induce lower welfare than optimistically implied by analysis that ignores information asymmetries.

In the last couple of decades, a large body of research has developed on incentive compatibility. Some very interesting results have emerged, most notably, the 'revelation principle.' To define this concept, we first define an 'allocation mechanism' to be a set of rules that specify questions to be asked of participants and the allocation decisions to be made based on each possible response (Harris and Townsend 1981). The revelation principle states, roughly speaking, that the actual performance of any allocation mechanism—including welfare losses due to misinformation—can be matched by a mechanism in which:

1. each participant is asked to give a complete, though potentially inaccurate, report of its private information, but,
2. it is in the best interests of each participant to truthfully report the private information (Green 1984).

In other words, while participants may choose to misinform, it is in their best interests not to, when faced with such a mechanism. The mechanism is referred to as a 'direct mechanism.'

The revelation principle has theoretical value as a standard against which to compare mechanisms used in practice; however, as Green remarks: "[r]ecently it has been suggested that the revelation principle may serve as a practical basis for the design of particular institutions such as auctions or regulatory procedures" (Green 1984). As Green observes, a significant problem with this approach to designing mechanisms is that giving a 'complete' report of private information would be an enormous undertaking. In the electric transmission context, every line impedance and every thermal and stability limit, all generator commitment and dispatch data and ratings, and all other power system parameters would have to be reported. The California

Public Utilities Commission's (CPUC's) Order on Models requires disclosure of all data used in analysis of transmission, but it remains to be seen if the amount of information involved can be usefully processed by the parties involved.

A natural alternative approach is to try to develop a version of the revelation principle that applies for 'summary information' (Green 1984), for example, corresponding to the revelation of, say, excess capacity between certain pairs of buses. This is the type of information revelation mandated by FERC in the PacifiCorp merger as 'Remaining Existing Capacity'. Green then points out, however, that except for special and unrealistic cases, the revelation principle cannot be applied to obtain truthful revelation of summary information.

A further practical limitation to the revelation principle is that finding a direct mechanism (as opposed to proving its existence), involves the solution of an optimization problem. Satisfactory characterizations of the solutions have only been developed in very restrictive cases, such as "when private information is represented by a state space which is either a finite set or a one-dimensional continuum" (Green 1984). This is a very serious limitation; however, "[t]he simplifying assumption that states are somehow naturally ordered along a one-dimensional continuum is ubiquitous in the incentives literature" (Green 1984).

Another avenue in the information asymmetry literature, which has potential in the transmission context, is auditing (Baron and Besanko 1984b). In this approach, an assessment is made, on the basis of *a priori* information as to whether or not the response to a question is truthful. If deemed untruthful, the participant is audited with some positive probability. Costly auditing is assumed to be able to reveal the true answer, and if the respondent has misinformed, a punishment is levied. A related avenue is the partial verification literature (Green and Laffont 1986, Singh and Wittman 1988), where it is assumed that large deviations from truthful responses are easily detected by the regulator.

Unfortunately, and as with the machinery developed around the revelation principle, it is necessary to have good *a priori* information about probability distributions of private parameters. We can interpret this assumption as meaning that, although the values of random parameters are unknown to the regulator at the time of any particular regulatory decision, the values become known after the fact so that probability distributions can be compiled relatively costlessly over the long term. In the long term, then, these statistics can be used to estimate the *a priori* probability distributions for parameters in future regulatory decisions.

Clearly, there is a fundamental contradiction between the need to have good *a priori* probability distributions and the assumption of costly auditing: by definition, a regulator cannot costlessly compile the probability distribution of private parameters about which it has no direct information except through active and expensive auditing. In fact, we have argued that transmission parameters are closely held proprietary information that are costly for regulators to audit both before and after the fact.

In general, the acquisition of *a priori* probability distributions is not explicitly modeled in the information literature, so that, following Knight's distinction, while there is risk associated with these models, there is no uncertainty (Knight 1964). This criticism applies, of course, to all Bayesian approaches but may be ameliorated in a continuing relationship consisting of repeated, similar events such as described in (Baron and Besanko 1984a). Repeated contracting for transmission access would come into this category; however, long-term contracting for firm access may not.

The problem of information asymmetry between protagonists is ongoing and unsolved at present. It is not surprising that the theory, practice, and software models described in Chapter 5 do not treat information asymmetry.

## **A.5 Co-ordination Losses in Transmission Planning Under Competitive Generation Supply**

### **Introduction**

In this Appendix, we pursue some of the consequences of the inherently complex cost structure of electric transmission in a setting of competition for generation supply. The complexity arises from economies of scale, lumpiness, and reliability criteria. These important features of transmission technology are typically down-played in classical economic analysis but will be emphasized here. We will argue that, even in the simplest of cases, the social planning problem for transmission network expansion has considerable computational complexity making it difficult to understand even in the presence of full information. In practice, information asymmetries are substantial. They raise two problems: the potential for strategic use of information and the potential for losses in coordination economies.

While recent proposals for utility resource acquisition through auctions mitigate the first problem to a great extent (Shirmohammadi and Thomas, 1991), the second problem remains. Losses in coordination economies can occur because the location decisions of private generators may not be known by the utility in sufficient time to plan network reinforcements optimally. Under these circumstances, generators may be interconnected 'one-at-a-time' through radial extensions that are collectively more expensive than jointly planned network expansions. The private generators do not know the optimal transmission capacity expansion plan since they do not know the cost function. The utility does not know where the new generation will be located, so it cannot plan optimally even knowing the cost function.

With greater coordination of transmission plans, there is an opportunity to realize scale economies. Unless siting locations are known with sufficient advance notice, however, these scale economies will be lost. Nevertheless, we will argue that the coordination losses are usually outweighed by benefits in competition, but that in some cases the transmission coordination losses are too large for competition to be beneficial.

In section 2, we characterize the transmission capacity cost structure including economies of scale, lumpiness, and reliability issues in transmission technology. In section 3, we analyze expansion of a hypothetical transmission network. We use an example, based on the physical structure of Kramer-Victor case, representing the simplest possible network configuration, and formulate the cost minimization problem for this case in the presence of full information. In section 4 we consider the problem faced by the regulator of an electric utility who has limited information. We estimate the extent to which benefits from competition in the generation segment offset coordination losses in transmission planning, and what determines the trade-off. Broadly speaking, competitive benefits dominate coordination losses for baseload generation and, depending on relative interconnection costs, for some intermediate generation.

## **Transmission Cost Characteristics**

In this section, we describe the issues of economies of scale, lumpiness, and reliability in relation to electric transmission technology.

### ***Economies of Scale***

Classical economies of scale are described by a cost versus capacity curve whose average costs are decreasing. Transmission 'cost' should be interpreted as the cost per unit length. Transmission 'capacity' should be interpreted as the 'thermal' capacity of the line, in megawatts (MW), say. Thermal capacity is defined to be the maximum power that can be transmitted along the line without causing accelerated aging of the line. We ignore a number of other engineering factors that enter into the definition of transmission capacity and further complicate the cost structure.<sup>18</sup>

### ***Lumpiness***

The classical economic notion of economies of scale applies to a technology that is continuously divisible. The capacity of electric transmission lines is not well described by this assumption because the capacity of electric transmission facilities depends, among other things, on the operating voltage of the line. Operating voltages are standardized into a small number of widely spaced levels, so that the capacities are typically available only in discrete lumps. We will consider the case where two voltage levels, 115 kilovolts (kV) and 220 kV, say, are candidates for construction. Figure 1 shows the construction costs versus capacity at these two voltage levels. Although the costs are in fictitious money units and the lengths are in fictitious distance units, the ratios of costs are representative of the data in (EPRI, 1986; Kelly *et al.*, 1987).

---

<sup>18</sup> For example, issues such as losses, reactive power, surge impedance loading, and emergency ratings of the line will be ignored in this paper. These concepts are described in detail in (Stoll, 1989).

At any given voltage level, it is standard practice to build towers to support either one or two sets of transmission lines. These are referred to as single-circuit and double-circuit construction, respectively. The capacity of double-circuit construction is approximately twice that of single-circuit construction; however, the costs of double-circuit construction are considerably less than twice the costs of single-circuit construction. Consequently, along a given corridor, the first, third, fifth, etc lines have approximately the same costs, while the second, fourth, sixth, etc lines, if built using double circuit construction, have a lower cost. This gives rise to the alternating staircase cost characteristic in Figure 1. Assuming that all construction must be either at 115 kV or 220 kV, the minimum cost of thermal capacity is shown by the lower envelope of the two cost characteristics in Figure 1.

Figure 1 illustrates significant economies of scale, but also reflects the lumpiness of construction. Lumpiness with economies of scale produces average costs that vary significantly as capacity changes, even at high levels of capacity. This should be contrasted with lumpiness in the absence of economies of scale, where at high levels of capacity the variation in average costs is only a relatively small perturbation about an approximately constant level. The average costs of the capacity in Figure 1 vary by over fifty percent even at high capacity levels. A classical smooth representation of the cost of capacity is a poor representation of the real costs, but is a convenient simplification (Scherer, 1976).

### ***Reliability Criteria***

The thermal capacity ratings shown in Figure 1 still do not provide enough information to design a transmission system. Transmission lines occasionally fail. To prevent failures from overloading other lines, it is standard practice to design transmission systems according to the 'N-1 criterion.' (Stoll, 1989). This criterion requires that after failure of any one of the N lines in the system, load can still be served without overloading any of the remaining lines past their emergency ratings. For simplicity, we will assume that the emergency ratings of the lines we consider are the same as the thermal ratings.

In general, to verify that the N-1 criterion is satisfied, 'loadflow analysis' (Bergen, 1986; Stevenson, 1982) must be performed for each possible outage of a line in the system. For real networks this can be computationally intensive. In this paper, for the sake of simplicity, we will mostly be concerned with corridors of parallel, identical lines. In this case, failure of one line will cause the flow to redistribute evenly amongst the other lines. Therefore, in the absence of other means to supply load, the N-1 criterion requires that the flow down a corridor be no greater than the thermal capacity of the number of lines in the corridor minus one.<sup>19</sup> We will call this the 'reliable' capacity of a corridor.

---

<sup>19</sup> This simplification applies only to corridors of parallel identical lines. In general, a corridor may consist of different types of lines, or two points can be joined by lines along several different paths. In this case, loadflow analysis is usually necessary to determine whether the N-1 criterion is satisfied.

Figure 2 shows the construction cost versus reliable capacity at 115 kV and 220 kV respectively. The minimum cost of reliable capacity is shown by the lower envelope of the two cost characteristics in Figure 2. Note that these costs apply for *de novo* construction: for example, it is not possible to start with 115 kV construction and achieve a higher capacity at 220 kV for the incremental costs implied in Figure 2.

In contrast, consider the case where a line is added to reinforce an existing corridor of lines. Assume that all lines have the same voltage. Suppose that the existing corridor satisfies the N-1 criterion. To a first approximation, adding capacity will increase the *reliable* capacity by the added *thermal* capacity. Therefore, the cost of adding capacity, at the same voltage, to an existing reliable corridor is the cost of incremental thermal capacity, as shown by the lower envelope in Figure 1.

In summary, incremental capacity costs depend on the level of existing capacity in the network. We have described two types of capacity. In the next section, we will illustrate these types of capacity with a transmission planning example. We note that in a real network the effects of 'reactive power' (Stoll, 1989) and network externalities make the effective cost of capacity highly dependent on knowledge of the existing capacity in the system.

### **Example Planning Problem**

In this section we characterize what we take to be the simplest possible transmission planning problem. It involves a choice between 'radial' interconnection and 'network' reinforcement for a generation source that is remote from the existing grid. The complexity of the problem involves the coordination of transmission plans for the remote source with plans for generation expansion at a location that is already connected to the grid. We describe the situation qualitatively in subsection 3.1, formulate the cost minimization problem formally in subsection 3.2, and describe features of the solution in subsection 3.3.

#### ***Description***

Figure 3 shows a simplified hypothetical transmission system. Its similarity to Figure 4-3 is not accidental. We abstract from the particular features of the Kramer-Victor case in the following manner. Node K is an existing center of generation joined to V, a load center, by a corridor of 115 kV and 220 kV transmission lines. The corridor satisfies the N-1 criterion, but has no excess capacity. There is growing load at V. There is potential expansion of the generation capacity at both K and H; however, there is no existing transmission between H and K nor between H and V.

As discussed in the last section, transmission capacity expansion along the K—V corridor will expand the reliable capacity of the corridor by the thermal rating of the new line. Therefore, the reliable cost versus incremental capacity curve for the corridor is represented by the thermal

cost data of Figure 1. New transmission expansion along the H—K or H—V routes, however, has a reliable capacity versus cost curve as in Figure 2.

Because of the costs of incremental capacity, it is reasonable to assume that increased generation at K should be accommodated by increased capacity along the K—V corridor. Although it adds to the existing 'network,' we will think of this expansion as 'radial' since it does not introduce any loops into the transmission system. For generation constructed at H, however, there are two basic alternatives:

1. Direct construction along the two unit long route from H to V, which we also refer to as 'radial' expansion, or,
2. Construction along the one unit long route from H to K, interconnection at K, and construction along the K—V corridor, which we refer to as 'network' expansion.

Despite the network expansion being along a longer route, the lower effective reliable capacity cost along the K—V corridor can justify network expansion over radial. Furthermore, if there is also expansion of the generation at K, economies of scale can make network expansion much more attractive than radial expansion.

### *Social Problem*

In this subsection, we formulate the problem of minimizing the cost of transmission expansion to satisfy fixed generation expansion plans at H and K. The overall social problem is then to minimize the total costs of generation and transmission over choices of generation expansion at H and K. Consistent with the 115 kV and 220 kV transmission options, we assume that the total new generation at H and K is no more than approximately 1000 MW.<sup>20</sup>

Let the minimum cost versus thermal capacity envelope shown in Figure 1 be described by the function  $T(K)$ , while the minimum cost versus reliable capacity envelope shown in Figure 2 be described by the function  $R(K)$ , where  $K$  is the level of transmission capacity expansion. Let the increased generation at H and K be  $G_H$  and  $G_K$ , respectively; let the increased reliable transmission capacity from H—K and H—V be  $K_{H-K}$  and  $K_{H-V}$ , respectively; and, let the increased thermal capacity from K—V be  $K_{K-V}$ .

---

<sup>20</sup> For generation increments greater than 1000 MW, economies of scale would encourage us to also investigate transmission construction at 345 kV and 500 kV.

To satisfy transmission requirements, we must have:

$$\begin{aligned} G_H + G_K &\leq K_{H-V} + K_{K-V}, \\ G_K &\leq K_{K-V}, \\ G_H &\leq K_{H-V} + K_{H-K}. \end{aligned}$$

The first of these constraints ensures that there is enough transmission capacity to deliver the incremental generation at V; the second ensures that there is enough capacity leaving K to accommodate generation at K;<sup>21</sup> while the third ensures that there is enough capacity leaving H to accommodate generation at H. The reader can verify that these are necessary and sufficient conditions for adequate transmission. Other equivalent sets of constraints are possible.

The costs of the transmission expansion are:

$$2R(K_{H-V}) + \sqrt{3}T(K_{K-V}) + R(K_{H-K}),$$

where the coefficients follow from the lengths of the transmission paths in Figure 3 and where the cost function,  $T$  or  $R$ , is applicable depending on whether there is already transmission capacity in the corridor. For fixed values of  $G_H$  and  $G_K$ , the optimal transmission expansion is given by the solution to the following problem:

$$\min_{\substack{K_{H-V}, K_{K-V} \\ K_{H-K}}} \{2R(K_{H-V}) + \sqrt{3}T(K_{K-V}) + R(K_{H-K}) : \begin{aligned} G_H + G_K &\leq K_{H-V} + K_{K-V}, \\ G_K &\leq K_{K-V}, \\ G_H &\leq K_{H-V} + K_{H-K}. \end{aligned}\}.$$

### *Solution*

In this subsection, we describe the characteristics of the solution to the transmission planning problem. By our definition of 'network' expansion, for a fixed  $G_H$  and  $G_K$  the optimal expansion involves network construction if and only if  $K_{H-K} > 0$ . Figure 4 shows whether optimal construction involves radial or network expansion versus the amount of increased generation at H and K. Optimal expansion is always radial if  $G_H = 0$  or if  $G_K = 0$ ; that is, optimal expansion is radial if generation expansion occurs at only one of the sites. If there is expansion at both sites, then optimal expansion is more often network. For  $G_H + G_K < 1000$  MW, optimal expansion is almost always network.

---

<sup>21</sup> We assume that all generation at K can be thought of as flowing along the K-V corridor. This is not true in general because of 'loop flow;' however, the assumption is innocuous here.



Figure 5 shows the optimal cost of expansion versus increased generation. The overall social problem is then to minimize the total costs of generation and transmission over feasible values of  $G_H$  and  $G_K$ . There are large regions in Figure 5 where the marginal cost of incremental capacity is zero due to the lumpiness of construction. Furthermore, there are large discontinuities in the cost and average cost functions even at high levels of incremental capacity, so that smooth approximations to cost functions assume away the complexity of the transmission decision process.

The transmission expansion costs in Figure 5 is optimal for the given generation expansion at H and K. Suppose that, instead, the transmission needs for H were determined assuming no increased generation at K, and vice versa. Then the total costs to accommodate expansion at both sites are higher. As shown in Figure 4, independent planning of the transmission needs of incremental generation at H and K will usually suggest radial transmission, which will usually be qualitatively in error compared to the optimal coordinated expansion.

Figure 6 shows the percent savings of the optimal joint plan over independent planning of the transmission requirements for H and K. Over wide ranges of values of  $G_H$  and  $G_K$ , the optimal joint plan is considerably less expensive than independent planning. Joint planning to accommodate expansion at both H and K often allows a single larger transmission line to be built between K and V to take advantage of economies of scale. However, with other network configurations, independent planning may under-estimate costs due to network effects not considered in this paper. Independent planning not only yields plans that are qualitatively different from the optimal, but also yields costs that differ significantly from the optimal costs.

Due to the lumpiness of construction, there can be 'excess' capacity in an optimally planned system. If the excess capacity can be used in the medium term for transmitting power from subsequently built generation capacity, then the effects of lumpiness can be smoothed; however, radial transmission built to access isolated producers may not be easily marketable. Historically, it has been assumed that excess capacity will be used eventually as the system grows. In the presence of fast anticipated growth, the economies of scale and long-life of transmission capital therefore dictate overbuilding relative to current needs. This has been the rule of thumb in transmission planning; however, if transmission costs are assigned to third parties, they may be unwilling to pay for overbuilding relative to their minimum needs (Hunt, 1992). Furthermore, historical rates of load growth may no longer be sustainable.

In summary, economies of scale and the reliability criterion significantly influence planning by making network expansion relatively cheaper than radial. In the planning of real transmission networks, the choices are often between many more than two possible expansion options since the network is usually much more complicated than in our simplified example. There may be some excess capacity already in the network, making the incremental capital costs of increased loading essentially zero. In practice, characterizing the incremental cost function is much more difficult than described in our example. In the next section, we will explore the ramifications of this social planning problem for a regulator.

## **Regulatory Problem**

The regulator's problem, narrowly construed, is to set up conditions that will achieve the welfare optimal transmission plan, or close to it, in the face of the limited information the regulator has concerning costs and excess capacity. More broadly, this objective must be traded off against other possibilities for minimizing the cost of electricity. In the following two subsections, we focus on the joint costs of generation and transmission expansion, considering the cases of vertical integration and partial vertical disintegration. In subsection 4.3, we characterize the conditions under which the benefits of competition in generation will outweigh the coordination losses in transmission.

### ***Vertically Integrated Utility***

Under vertical integration of the electric utility industry, the utility plans both generation and transmission expansion. Because the utility is aware of its potential generation opportunities, there is usually ample opportunity for the utility to coordinate and optimize its generation and transmission plans. In terms of the problem formulated in section 3, the utility can optimize the generation and transmission plan with full information. The optimal solution may involve some excess transmission capacity due to scale economies and lumpiness. The regulator faces the traditional problem under vertical integration of motivating the utility to optimize its capital planning, having only limited information about costs. This problem has been treated at great length in the public utility economics literature (Berg and Tschirhart, 1988; Crew and Kleindorfer, 1986).

### ***Partial Vertical Disintegration***

The planning problem is exacerbated in a partially disintegrated industry. This situation is becoming more typical as utilities contract with independent power producers and qualifying facilities. Under partial disintegration the regulator has the opportunity to drive down the price to the ratepayers through competition in the generation segment. Since the cost of generation is often substantially greater than the cost of transmission, small economies in generation may outweigh coordination losses in transmission planning. For this reason, there is strong pressure away from vertical integration in electricity. It is not clear, however, how far the competitive pressure in the generation segment should be pushed.

As indicated in the introduction, the information needed to perform the calculation of the transmission cost function is usually under the exclusive control of the utility owning the network. Information asymmetries between the utility and independent producer over transmission costs and capacities confer market power to the utility. Recent proposals requiring that utilities reveal transmission interconnection costs to private generators *prior* to formal competitive bidding mitigate this problem to a substantial degree. However, the disclosure typically involves estimates of the radial interconnection costs with the utility performing detailed

network planning only after the bids have been accepted and contracts signed (Shirmohammadi and Thomas, 1991).

The problem then still remains of integrating the transmission needs of independents into the long-term transmission plans of the utility. For example, if the generation additions at H and K in section 3 are privately owned, the utility may not know how much capacity will be interconnected at both sites in time to plan optimally and take advantage of coordination economies. In contrast, utility plans for generation will be available to transmission planners at a much earlier stage of development. Large transmission projects typically must be certified at a public utility commission, necessitating lead times for transmission projects that are as long or longer than the lead times for generation projects. Therefore, gains from competition in the generation segment may be offset by coordination losses in transmission planning.

To attempt to eliminate the coordination loss, the regulator might require the utility to investigate and disclose all possible transmission expansion plans involving multiple site locations. The example in section 3 indicates that this task is at a minimum computationally challenging. Even if some limited approximation to it were available, the regulatory outcome might still not be desirable. Suppose the utility does disclose information on the potential economies of joint siting and interconnection. Two bidders might then coordinate their proposals to capture these economies. The net social economy would not necessarily be reflected in lower prices paid by utility ratepayers, since collusion between bidders could capture most of the rent through higher bids for generation.

An appropriate regulatory policy, therefore, involves balancing the gains from competition in the generation segment against the potential coordination losses in transmission planning. We formalize this trade-off to determine the conditions under which the gains from competition in generation exceed the coordination losses in transmission.

From Figure 6, we observe that, over a wide range of choices of generation expansion, the coordination losses of independent planning are relatively large as a fraction of the transmission expansion costs. These losses occur regardless of what type of generation capacity is installed. We can express the transmission coordination losses as the product of the percentage coordination loss,  $CL$ , and the total transmission expansion cost,  $TC$ .

In contrast, the benefits of competition in generation depend partly on the type of generation capacity installed. They are typically greater for baseload generation, which operates for most hours of the year, than for peaking generation, which operates for brief periods of time. We parametrize the costs and benefits of competition in the generation segment to illustrate the importance of this effect.

We express the gains from competition in the generation sector as the product of a percentage competitive benefit,  $\alpha$ , times the cost of generation,  $GC$ . The generation costs,  $GC$ , are the sum of fixed costs,  $FC$ , and total variable costs. Total variable costs are approximately proportional to the number of hours per year that it is optimal to operate a particular generator. This optimal

operating profile is determined by simulation of the power system dispatch (Stoft and Kahn, 1991). We use standard power industry terminology to describe the operating profile as a percentage capacity factor,  $CF$ . Finally, it is convenient to define a proportional relationship between variable generation cost and  $TC$ , parametrized by a multiplier  $\beta$ . Therefore, the gains from competition are  $\alpha[FC + \beta \cdot CF \cdot TC]$  and they exceed coordination losses for those capacity factors that satisfy:

$$CF > CL/\alpha\beta - FC/(\beta \cdot TC).$$

By estimating the parameter values in the right hand side of this expression, we can gain some insight into the conditions that are likely to make competition the desirable regulatory strategy.

### *Numerical Estimates*

There are estimates of the value of  $\alpha$  available in the literature. The range is approximately between 0.1 (Kahn, 1991) and 0.2 (Lieberman, 1992). Figure 6 gives a rough estimate for  $CL$  of approximately 25% for the region  $G_H + G_X < 1000$  MW. Based on these estimates,  $CL/\alpha$  is between 1 and 3. The generation costs,  $GC$ , are known approximately as a function of  $CF$ . In present-value \$/kW,

$$GC(CF) = 600 \text{ \$/kW} + CF \cdot 4700 \text{ \$/kW}.$$

This approximation is consistent with avoided cost information used by Consolidated Edison in a competitive bidding context (Consolidated Edison, 1990). On the basis of this parametrization,  $FC/(\beta \cdot TC) = 13\%$ . To determine  $\beta$ , we estimate  $TC$  and use the relationship between total variable costs and transmission costs:  $\beta \cdot TC = 4700$  \$/kW.  $TC$  can be quite variable, depending upon local conditions. A typical range is,  $TC = 200\text{--}300$  \$/kW (Pacific Gas and Electric, 1991). A high cost case, such as Consolidated Edison, would be  $TC = 1000$  \$/kW. Using this range of values, we get  $20 > \beta > 5$ .

The implication of these estimates is the following. For most cases where transmission costs are small compared to generation costs, competition is beneficial for  $CF > 10\%$ . This means that only the 'peaking' technology segment of the market should be protected from competition. In areas where transmission system costs are high, competition should be confined to high capacity factor (baseload) market segments. For  $\beta = 5$  and  $CL/\alpha = 3$ , the critical capacity factor is around 50%. In this case, the intermediate load segment of the market may or may not be a beneficial arena for competition.

## **Summary and Conclusion**

Transmission capacity expansion is an essential feature of wholesale competition in electricity. The cost structure for this kind of capacity is complex even in what appears to be relatively simple cases. The utility, as a monopoly supplier of this capacity, has private information about these costs that is very difficult for the regulator or private suppliers to audit or verify. Under vertical integration, the utility can, in principle, optimize the joint costs of generation and transmission system expansion. Unfortunately, the regulator can never really be assured that the minimum cost solution has been obtained.

The regulatory motivation for wholesale competition in generation is price reduction. The competitive process for selecting private suppliers must be coordinated with the transmission impacts of such selection. Because the interconnection of private suppliers is typically a 'one-at-time' process, the coordination economies of network expansions may be lost. It is practically infeasible to require the utility to disclose the costs of all possible network expansion alternatives in advance of bidding for generation capacity. Furthermore, pursuing this goal will only encourage collusion among bidders. Therefore, the regulatory policy of wholesale competition will inevitably result in some transmission planning inefficiencies.

We have estimated the extent of these inefficiencies, compared them to potential gains from competition, and derived a relation characterizing when the balance favors competition. Broadly speaking this usually occurs for generation capacity that is optimally dispatched in the baseload or intermediate mode. For peaking generation (capacity factor of less than 10%), the competitive benefits may be insufficient. In systems with very high cost transmission, the optimal capacity factor for competition benefits is much higher. We gave an example where it is approximately 50%.

Many of the problems identified here have already occurred to one extent or another in the private wholesale markets. The Kramer-Victor case is one example. We expect that these and franchise monopoly that is evolving in the U.S. electricity system.

Figure 1. Cost of thermal capacity, in arbitrary money units per unit length, versus thermal capacity. Capacity at 115 kV shown by the thin line; capacity at 220 kV shown by the thick line; minimum costs are given by the lower envelope of the two curves.

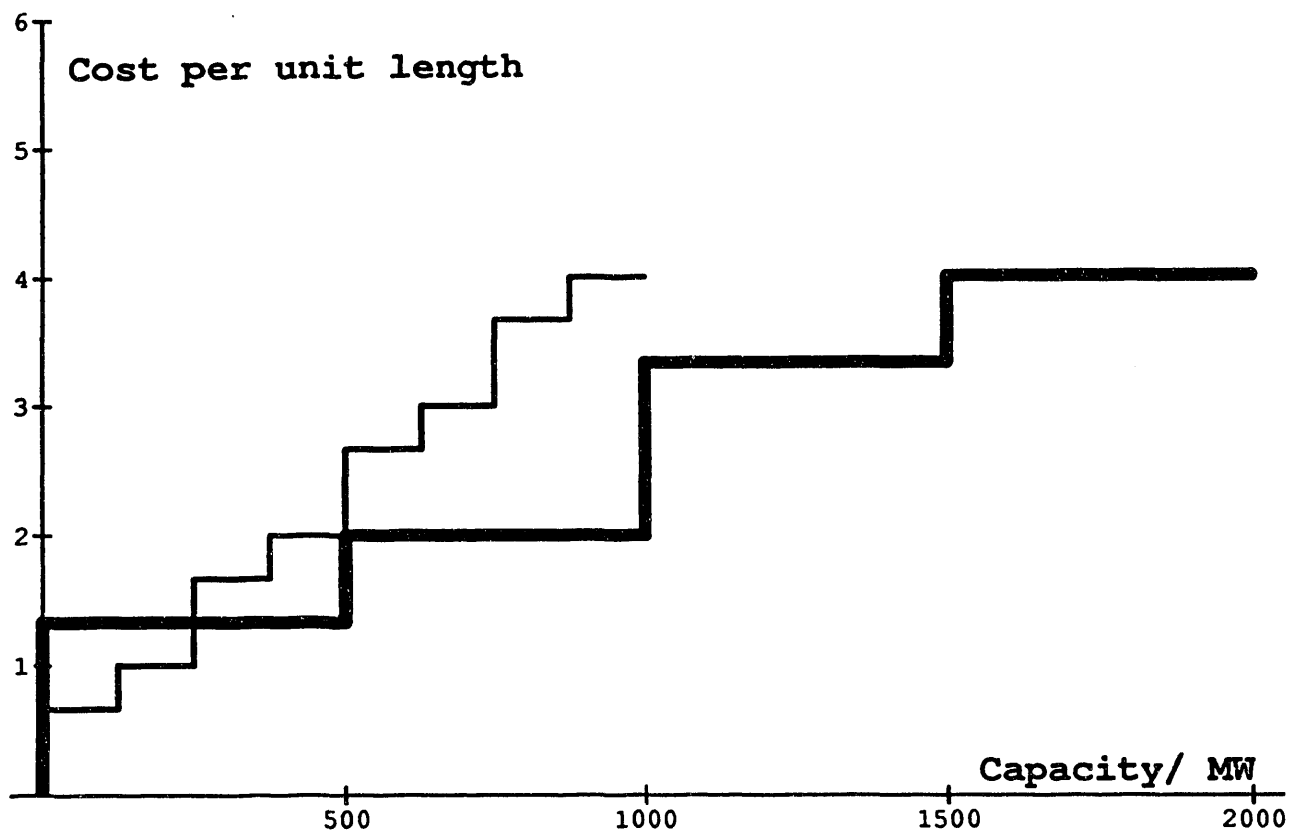

Figure 2. Cost of reliable capacity, in arbitrary money units per unit length, versus reliable capacity. Capacity at 115 kV shown by the thin line; capacity at 220 kV shown by the thick line; minimum costs are given by the lower envelope of the two curves.

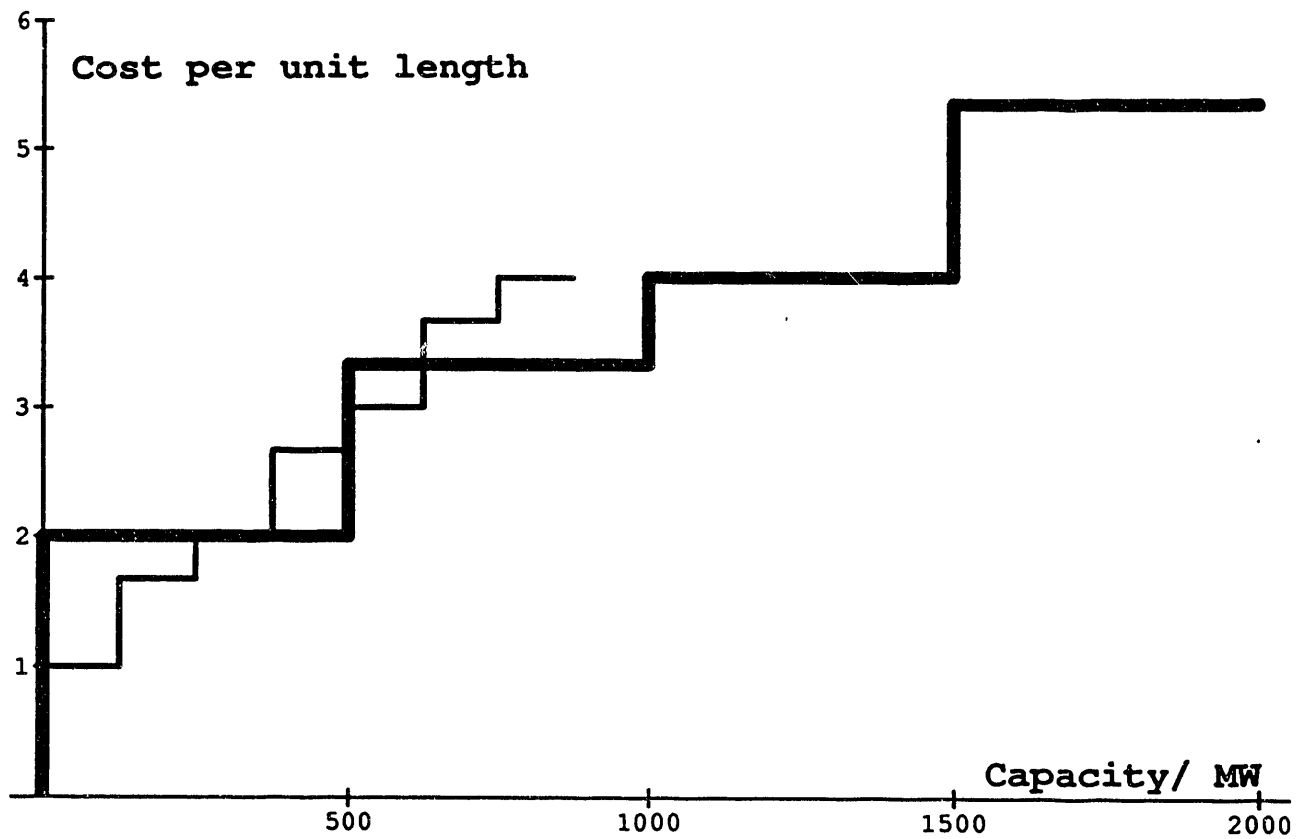

Figure 3. Example system.

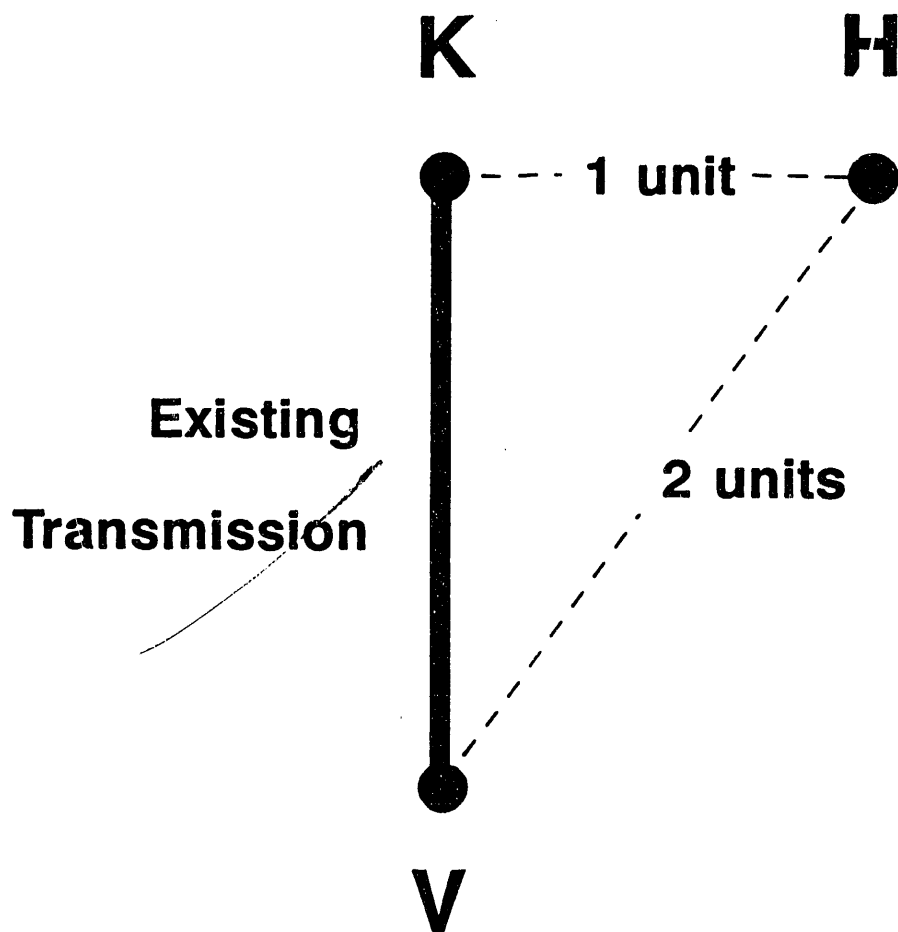



Figure 4. Qualitative nature of optimal construction versus generation expansion at H and K. Construction should be network in white regions, radial in black regions. (Optimal planning was performed for values of  $G_H$  and  $G_K$  in multiples of 10 MW. The shading of each 10 MW by 10 MW square represents optimal planning for the value of  $(G_H, G_K)$  in the bottom left corner of the square.)

$G_H / 10 \text{ MW}$

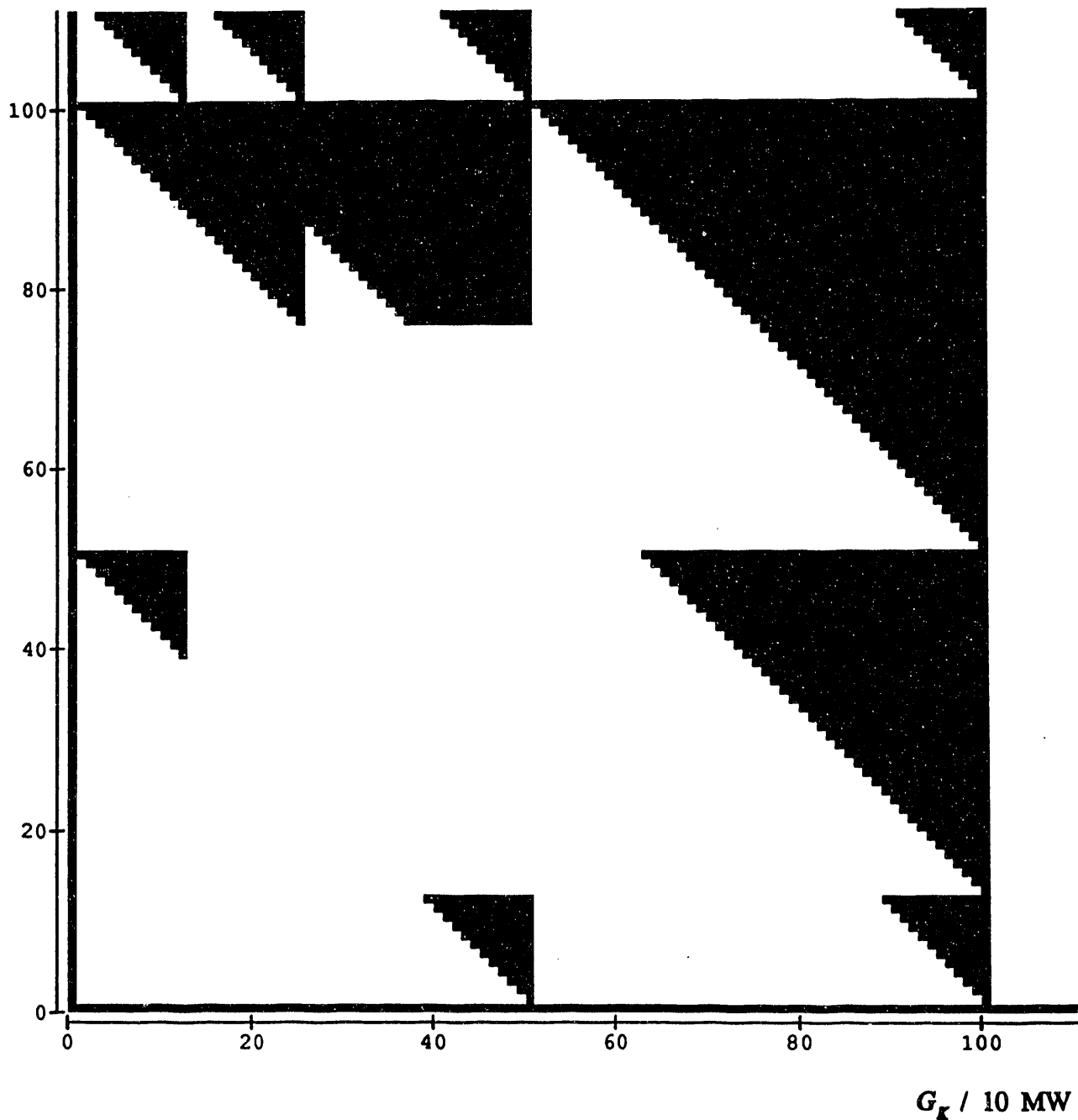

Figure 5. Optimal costs of transmission versus generation expansion at H and K.

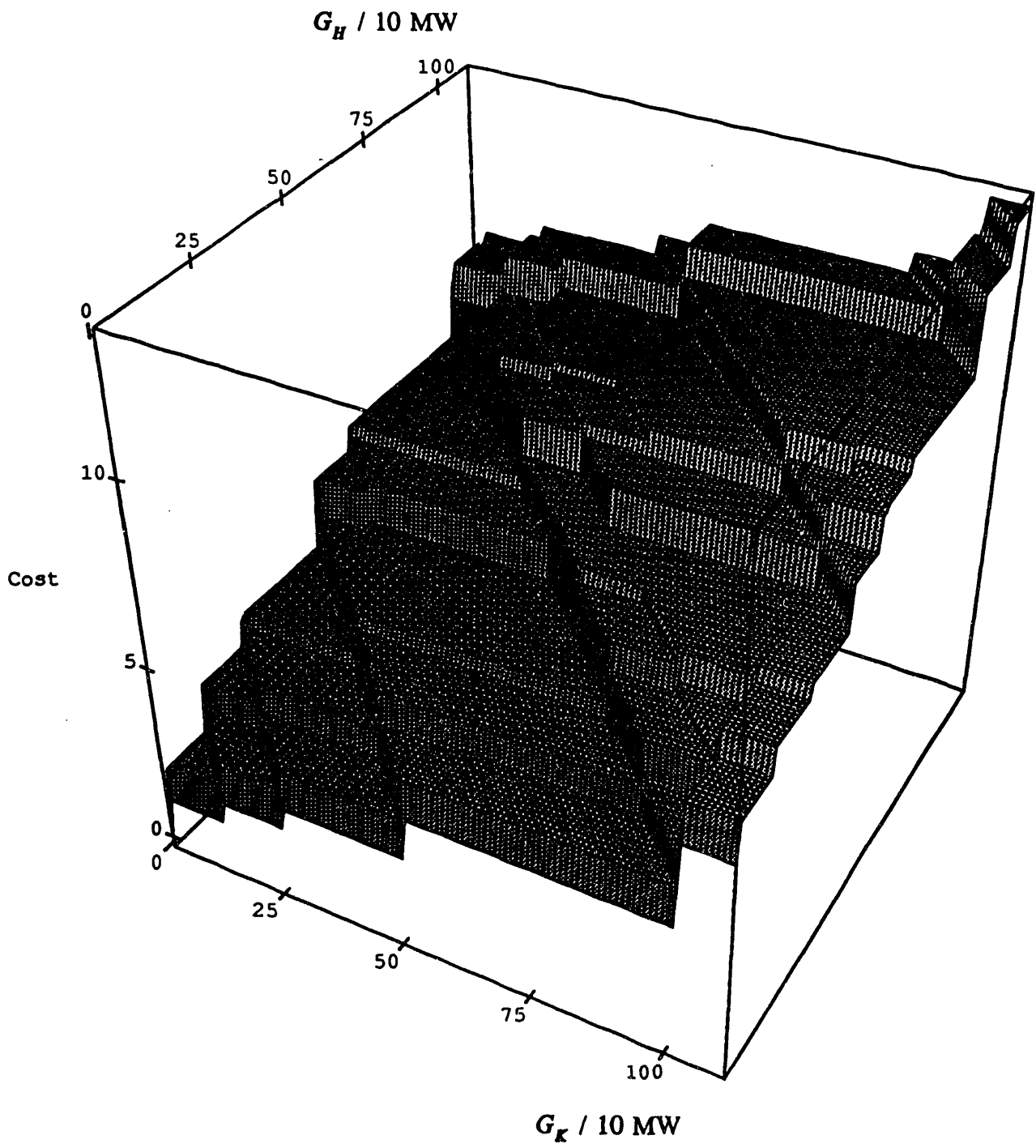
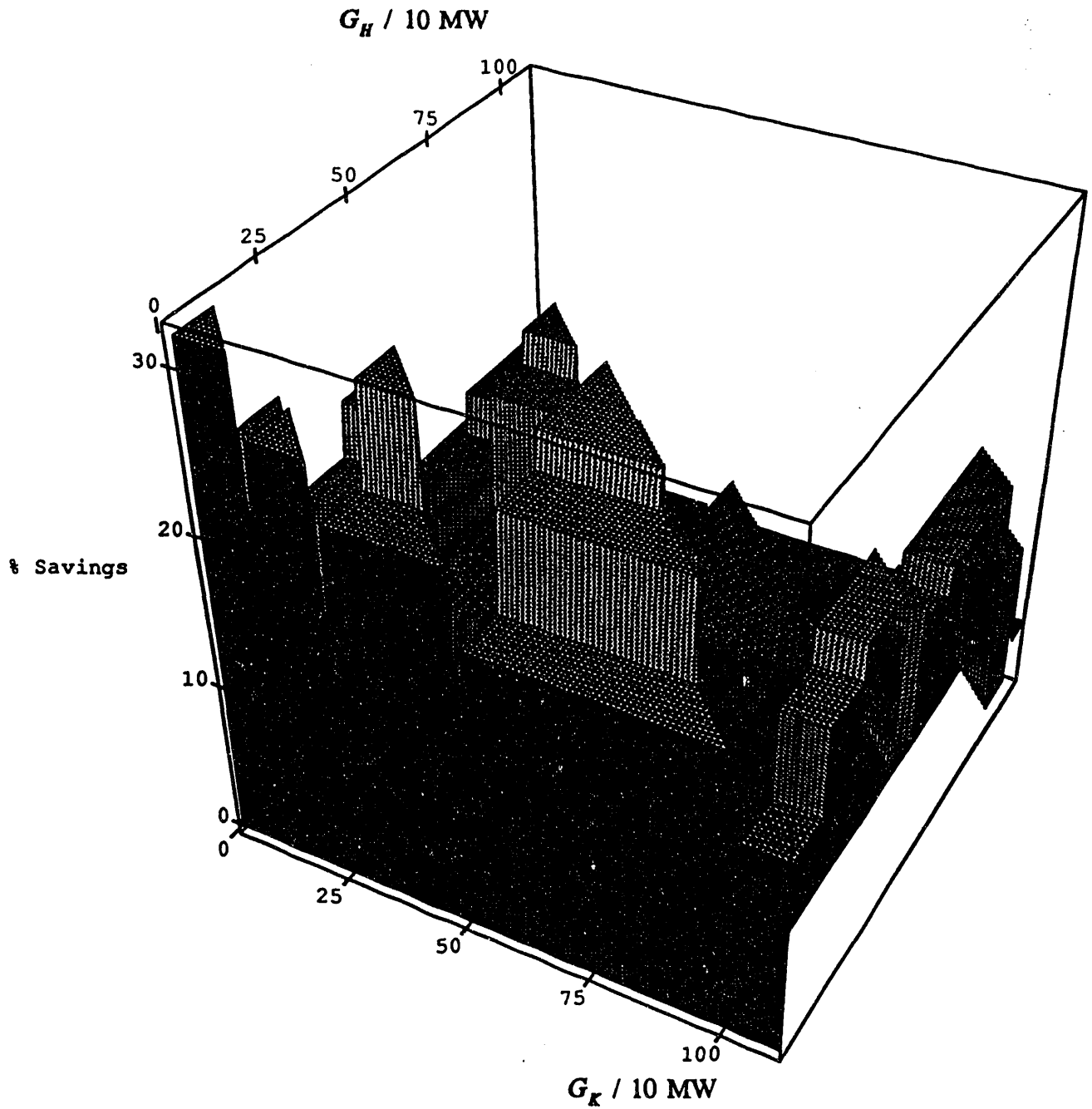

Figure 6. Percent savings of jointly optimal plan over independent planning versus generation expansion at H and K.



**END**

**DATE  
FILMED**

**8 / 31 / 93**

