



ERNEST ORLANDO LAWRENCE BERKELEY NATIONAL LABORATORY

Status of Overseas Microgrid Programs: Microgrid Research Activities in the U.S. (English version)

Chris Marnay and Nan Zhou

Environmental Energy
Technologies Division

February 2008

<http://eetd.lbl.gov/EA/EMP/emp-pubs.html>

The work described in this report was funded by the Office of Electricity Delivery and Energy Reliability, Distributed Energy Program of the U.S. Department of Energy under Contract No. DE-AC02-05CH11231.

Disclaimer

This document was prepared as an account of work sponsored by the United States Government. While this document is believed to contain correct information, neither the United States Government nor any agency thereof, nor The Regents of the University of California, nor any of their employees, makes any warranty, express or implied, or assumes any legal responsibility for the accuracy, completeness, or usefulness of any information, apparatus, product, or process disclosed, or represents that its use would not infringe privately owned rights. Reference herein to any specific commercial product, process, or service by its trade name, trademark, manufacturer, or otherwise, does not necessarily constitute or imply its endorsement, recommendation, or favoring by the United States Government or any agency thereof, or The Regents of the University of California. The views and opinions of authors expressed herein do not necessarily state or reflect those of the United States Government or any agency thereof, or The Regents of the University of California.

Ernest Orlando Lawrence Berkeley National Laboratory is an equal opportunity employer.

Microgrid Research Activities in the U.S.

Chris Marnay and Nan Zhou
15 November 2007

1. Introduction

Research on microgrids in the U.S. has taken a somewhat different path than parallel efforts in Japan and Europe, and this distinction is often noted in international research forums. In general, reliability and power quality in North America is poor compared to other developed countries. For example, in the U.S., the average annual expected outage duration is a few hours, whereas in Japan, it is only a few minutes. Power quality problems in the U.S. are both large scale, such as the August 2003 blackout, and local, such as damaging voltage sags. Meeting the increasingly demanding requirements of a modern digital economy would then seem to offer a more daunting challenge for the U.S. than elsewhere, and certainly, concern that the existing power delivery system will prove inadequate for future gourmet requirements has been a motivating driver of U.S. research. This objective tends to translate into a desire for microgrids to seamlessly island when grid power is interrupted or its quality is inadequate, and to (also seamlessly) reconnect when normal service has been restored. In a sense, the microgrid is perceived as acting as an uninterruptible power supply (UPS), and sometimes even as a competitor to existing UPS options. Nonetheless, this difference is often over-stated, and the other threads that motivate microgrid research also exist in the U.S., e.g. the desire to expand renewable generation and the need to increase the efficiency of fossil-fired generation by the useful local application of waste heat in combined heat and power (CHP) systems. Further, over time, the differences are blurring as concerns about climate change increasingly dominate objectives worldwide. This article describes the CERTS Microgrid, which is almost certainly the best known U.S. example, and also briefly mentions some other U.S. microgrid research.

2. The CERTS Microgrid

While thinking about microgrid concepts goes back further, the recent era of U.S. microgrid research began around the turn of the century when there was interest at the U.S. Department of Energy (DOE) in restarting a research program focused on grid reliability, an area that had been somewhat neglected in the latter years of the last century. A blue ribbon committee identified the likely emergence of distributed generation as one of the key drivers for change in the overall power system, and as a result, the Consortium for Electric Reliability Solutions (CERTS) was established to research this and other topics related to grid reliability. The specific concept of the CERTS Microgrid (CM) was fully developed by 2002. It was described in a white paper, and presented at a CEC Workshop on 2 May 2002 [1], after which building physical examples was undertaken. This activity was also funded by DOE, but more recently the California Energy Commission (CEC) through its Public Interest Energy Research Program (PIER) has been the dominant funding source.

The CM, as with most microgrid paradigms, is intended to seamlessly separate from normal utility service during a disruption and continue to serve its critical internal loads until acceptable utility service is restored. The CM provides this function for

relatively small sites ($\sim < 2$ MW peak) without need for costly fast electrical controls or expensive site specific engineering. No single device is essential for operation, creating a robust system.

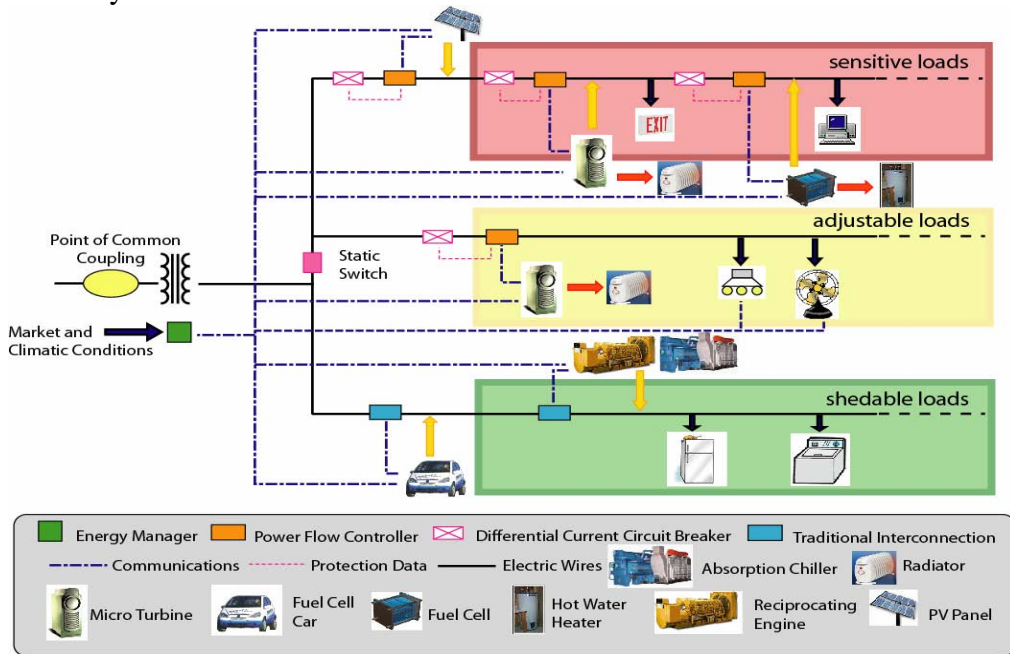

Figure 1 Schematic of an Example CM

Figure 1 shows an example CM. Note that it lacks fast electrical controls. The operation of generators is controlled locally by power electronic devices that incorporate droop characteristics that respond to local frequency and voltage. Consequently, devices that naturally require a power electronic interface, e.g. DC sources, are particularly amenable to incorporation in a CM. Also, a very fast switch is required to isolate sensitive loads when grid conditions or economics so dictate. As in Japanese microgrid demonstrations, it has a single point of common coupling (PCC), and does not usually export, i.e. to the utility it appears as a single controlled load no different from similar customers.

The CM is explicitly designed to provide heterogeneous power quality, which appears in the diagram as varying reliability on the three circuits. One circuit is shown as serving the *shedable* loads which are exposed to normal grid power. In the event of inadequate grid power quality, e.g. voltage sag, the static switch quickly opens and the other two circuits, shown as serving *sensitive* and *adjustable* loads, are served as an intentional island until acceptable power quality is restored. The CM requires no custom engineering for interconnection of any single device, as long as it has CM capability, making system configuration flexible and variable. Generators may not only be spread across circuits, they may be physically placed around the site, quite possibly co-located with convenient heat sinks that offer economically attractive CHP opportunities. Finally, other control functions, e.g. maintaining economic dispatch, are achieved by a generic slow control network represented in Figure 1 as the energy manager, which could be of many types, e.g. an add-on to a legacy building energy management system. The viability of the CM has been well demonstrated in simulation and through bench testing of a laboratory scale test system at the University of Wisconsin, Madison [2]. For

some time, it has been the CERTS objective to carry out full-scale testing of the CM concept before deploying it at an actual site. To accomplish this, a full scale test with a configuration similar to the one shown in Figure 1 has been installed for about a year at the Dolan Technology Center in Columbus OH, which operated by American Electric Power, one the largest electricity utilities in the U.S. Figure 2 shows the layout of the test bed. The white building contains the prime movers, three Tecogen 60 kW reciprocating engines generators based on a production General Motors 7.5 L engine. The other cabinets seen in Figure 2 contain the various switchgear and monitoring equipment needed to fully exercise the microgrid and record its performance during the scheduled test procedure.



Figure 2 Layout of the Dolan Technology Center CM Test Bed

Figure 3 shows results from early tests of two Tecogen 60 kW gensets similar to the ones being used in the Dolan demonstration. These units are based on a standard production automobile engine that has been widely deployed in the U.S. in traditional distributed generation. These traces show the state of the two such gensets during a disconnection from grid power. The active power of unit 2 overshoots maximum but then the control backs off the generation: then unit 1 increases its output to meet the loads. Voltage magnitude is unchanged and the frequency drops in both machines following the event. The time gap before steady state is reestablished is less than a second.

The role of storage in microgrid power quality enhancement is an active area of research in both the U.S. and Japan. Particularly, optimal sizing of storage and suitable technology choice are still unclear, and the cost and maintenance implications for microgrids could be significant. The Test Bed units shown in Figure 3 are equipped with simple battery storage on their DC buses, and Figure 4 shows its performance while switching in a 50kW load. The battery responds instantly to inject current during the genset ramp, and then settles into a voltage-supporting role in the absence to grid power.

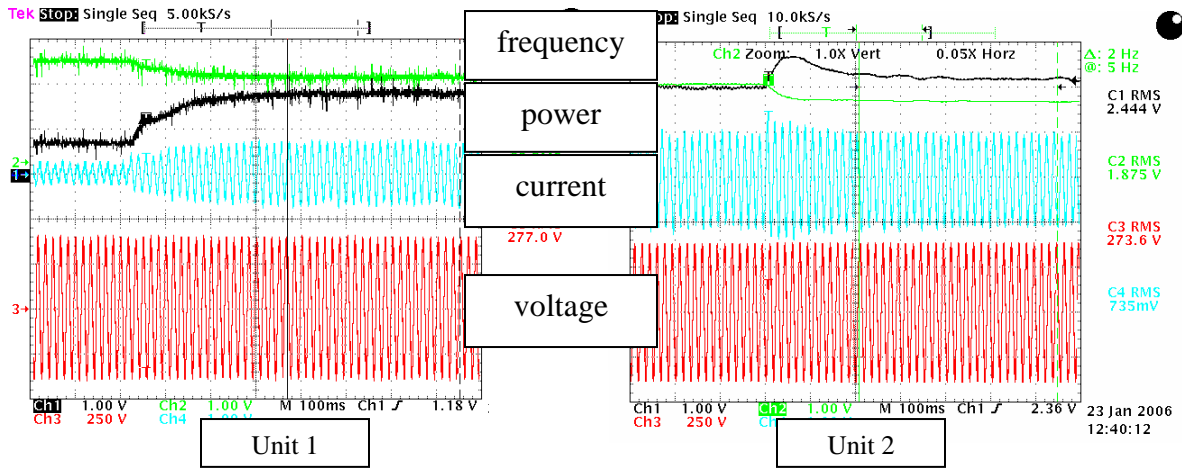

Figure 3 CM Test Results 1 (source: University of Wisconsin, Madison)

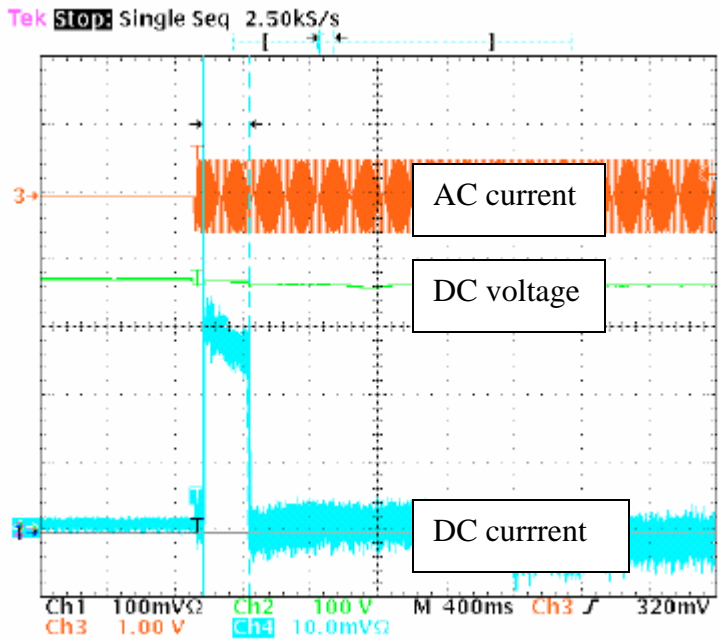

Figure 4 CM Test Results 2

One notable feature of the CM project has been simultaneous research into necessary tools for microgrid deployment, other than the actual electrical hardware. Two major products of this unified approach are a microgrid analysis tool, under development at the Georgia Institute of Technology, and the Distributed Energy Resources Customer Adoption Model (DER-CAM) in use at Berkeley Lab and several other R&D facilities worldwide. The later model finds, in a fully technology neutral fashion, the optimal combination of on-site generation required to meet end-use energy service requirements in a facility. It is able to analyze CHP, electrical and heat storage opportunities, and it is currently being extended to consider power quality and reliability issues.

3. Other U.S Microgrid R&D

DOE has also co-funded with General Electric a second separate two-year approximately 3 M\$ microgrid effort led by GE Global Research. Together with researchers from New Mexico Tech and at its facility, General Electric aims to develop and demonstrate a Microgrid Energy Management (MEM) framework for a broad set of microgrid applications that provides a unified controls, protection, and energy management platform. At the asset level, MEM is intended to provide advanced controls for both generation and load assets that are robust with respect to low-inertia environments. At the supervisory level, MEM will optimize the coordinated operation of interconnected assets in the microgrid to meet customer objectives such as maximizing operational efficiency, minimizing cost of operation, minimizing emissions impact, etc., and is also intended to enable integration of renewables and microgrid dispatchability.

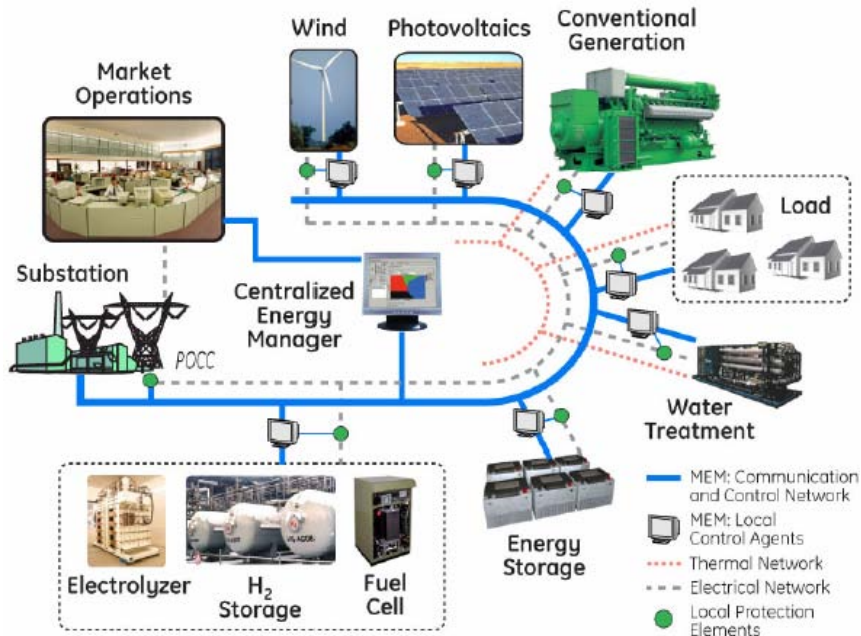

Figure 5 GE Research MEM Framework.

Microgrid research in the U.S. is progressing in several other directions. One that is unusual relative to developments elsewhere is the exploration of mobile microgrids. This concept is intended for emergency or other temporary support. Combinations of sources are mounted on trailers and moved around as needed. Another place that is poorly served by the grid are new communities in Texas, and a similar mobile approach is being applied there.

It should be mentioned that many other R&D activities under way in the U.S. that are not explicitly sailing under the microgrid flag are nonetheless developing standards, methods, and technologies that will support the deployment of microgrids.

Primarily funded by the CEC, the first full-scale integration test of commercial-grade utility grid interactive DERs in the U.S., the Distributed Utility Integration Test (DUIT), addresses a key technical issue, namely the electrical implications of operating multiple and diverse DER at high penetration levels in utility distribution networks

(<http://www.dual.com/DUIT>). Thorough testing is planned of the feasibility and value of co-location and integration of DERs into the electric distribution system.

Finally, one area in which the U.S. tends to have a large international influence is via the IEEE standards process. IEEE Standards Coordinating Committee 21 is currently supporting the development of IEEE P1547.4 Draft Guide for Design, Operation, and Integration of Distributed Resource Island Systems with Electric Power Systems. Currently in an initial draft stage, this document is intended to cover microgrids or intentional islands containing distributed resources (DR) connected to both local and area islanded electric power systems (EPS). This document provides alternative approaches and good practices for the design, operation, and integration of the microgrid. This includes the ability to separate from and reconnect to part of the area EPS while providing power to the islanded local EPSs. This guide includes the distributed resources, interconnection systems, and participating electric power systems, and is intended to be used by EPS designers, operators, system integrators, and equipment manufacturers. Implementation of this guide will expand the benefits of using DR by targeting improved electric power system reliability and build upon the interconnection requirements of IEEE 1547-2003 Standard for Interconnecting Distributed Resources with Electric Power Systems [3].

4. Conclusion

Microgrid research in the U.S. has followed a somewhat different path relative to Europe and Japan, although the differences are clearly narrowing because of the dominance of climate change concerns worldwide. The CM is the most preeminent example of U.S. work in this area, but other activities have also progressed and provided a useful contribution to the overall international effort. DOE has recently announced a plan to fund several microgrid demonstrations with a total of up to approximately 38 M\$ of funding available over the next few years, and the CEC is also expected provide additional funding for microgrid demonstrations in 2008 [4]. These projects should provide a boost to U.S. microgrid research and results of value to our colleagues worldwide.

[1] Lasseter, Robert, Abbas Akhil, Chris Marnay, John Stevens, Jeff Dagle, Ross Guttromson, A. Sakis Meliopoulos, Robert Yinger and Joe Eto. *Integration of Distributed Energy Resource: The CM Concept*. California Energy Commission, P500-03-089F, October 2003, available at: http://energy.ca.gov/reports/2003-11-21_500-03-089F.pdf.

[2] Paigi, Paolo and Robert Lasseter, "Autonomous Control of Microgrids," IEEE Power Engineering Society General Meeting, Montréal, Canada, June 2006.

[3] http://grouper.ieee.org/groups/scc21/1547.4/1547.4_index.html

[4] DOE Office of Electricity Delivery and Energy Reliability Research and Development Funding Opportunity Number: DE-PS26-07NT43119-00

[5] Corum, Lyn. "Backing Up the Grid," *Distributed Energy*, vol 5(5), September/October 2005.