



ERNEST ORLANDO LAWRENCE BERKELEY NATIONAL LABORATORY

Commercial Building Loads Providing Ancillary Services in PJM

Jason MacDonald and Sila Kiliccote
Lawrence Berkeley National Laboratories

Jim Boch, Jonathan Chen, and Robert Nawy
IPKeys Technologies, LLC

June 2014

Presented at *ACEEE Summer Study on Energy Efficiency in
Buildings 2014*

Pacific Grove, CA

August 17-22, 2014,

and published in the Proceedings

The work described in this report was funded by the
U.S. Department of Energy's Office of Electricity Delivery and Energy
Reliability, Transmission Reliability Program of the U.S. Department of
Energy under Contract No. DE-AC02-05CH11231.

Disclaimer

This document was prepared as an account of work sponsored by the United States Government. While this document is believed to contain correct information, neither the United States Government nor any agency thereof, nor The Regents of the University of California, nor any of their employees, makes any warranty, express or implied, or assumes any legal responsibility for the accuracy, completeness, or usefulness of any information, apparatus, product, or process disclosed, or represents that its use would not infringe privately owned rights. Reference herein to any specific commercial product, process, or service by its trade name, trademark, manufacturer, or otherwise, does not necessarily constitute or imply its endorsement, recommendation, or favoring by the United States Government or any agency thereof, or The Regents of the University of California. The views and opinions of authors expressed herein do not necessarily state or reflect those of the United States Government or any agency thereof or The Regents of the University of California.

Commercial Building Loads Providing Ancillary Services in PJM

*Jason MacDonald, Sila Kiliccote, Lawrence Berkeley National Laboratory
Jim Boch, Jonathan Chen, Robert Nawy, IPKeys Technologies, LLC*

ABSTRACT

The adoption of low carbon energy technologies such as variable renewable energy and electric vehicles, coupled with the efficacy of energy efficiency to reduce traditional base load has increased the uncertainty inherent in the net load shape. Handling this variability with slower, traditional resources leads to inefficient system dispatch, and in some cases may compromise reliability. Grid operators are looking to future energy technologies, such as automated demand response (DR), to provide capacity-based reliability services as the need for these services increase. While DR resources are expected to have the flexibility characteristics operators are looking for, demonstrations are necessary to build confidence in their capabilities. Additionally, building owners are uncertain of the monetary value and operational burden of providing these services. To address this, the present study demonstrates the ability of demand response resources providing two ancillary services in the PJM territory, synchronous reserve and regulation, using an OpenADR 2.0b signaling architecture. The loads under control include HVAC and lighting at a big box retail store and variable frequency fan loads. The study examines performance characteristics of the resource: the speed of response, communications latencies in the architecture, and accuracy of response. It also examines the frequency and duration of events and the value in the marketplace which can be used to examine if the opportunity is sufficient to entice building owners to participate.

Introduction

The adoption of low carbon energy technologies, such as variable renewable energy generation and electric vehicles, coupled with the effectiveness of energy efficiency at reducing traditional base load, has increased the uncertainty inherent in the net electricity load shape. This uncertainty can create reliability issues and market instability when attempting to balance load with generation through typical unit commitment and dispatch mechanisms (Helman 2010). Questions remain among electricity system operators and regulators as to which method to manage this uncertainty is best. One proposed solution is to increase either the amount or efficacy of operating reserve-based ancillary services (Helman 2010). Federal Energy Regulatory Commission (FERC) rules have attempted to open the markets to new resources, reduce uncertainty, and established market incentives for fast and accurate performance of frequency regulating reserve in response to these growing issues (FERC 2008, 2011, 2012).

Ancillary services (AS) are the non-energy products and services required to maintain reliability in the electricity system. FERC defined six required AS in their landmark rule 888 (1996), two of which were allowed to be market-based reserve products: operating reserve and frequency regulating reserve. Operating reserves are capacity held in reserve to be used in contingency events to balance the loss of transmission or generation on the system. These are classified into synchronous (or spinning), non-synchronous, and supplemental reserves.

Synchronous reserves are the unloaded synchronized capacity of generation and sheddable load that can be fully dispatched within ten minutes and are the most valuable and highest quality of the operating reserves. Both non-synchronous and supplemental reserves need not be synchronized but must be able to respond within 10 minutes and 30 minutes, respectively. The other major class of market-based AS is frequency regulation. A resource providing frequency regulation gives over a portion of their capacity to the system operator to control the output of to maintain the balance between supply and demand. Resources follow the automatic generation control (AGC) signal provided by the system operator every 2-6 seconds and supply telemetry to the operator to verify response. Frequency regulation is generally considered a higher quality product than synchronous reserve and paid more in the wholesale markets (MacDonald et al. 2012).

Demand Response (DR) resources to provide AS have been of particular interest to forward thinking regulators and system operators due to their potentially low capital cost and high quality of response (Kirby 2007; Callaway 2009; Ma et al. 2013). However, significant regulatory, market, and economic barriers exist have limited participation, including the uncertainty in the quality of a DR resource, the impact of providing it to the resource owners daily operations, and the uncertain value that these services are worth (Cappers et al. 2013). To date, the majority of resources that have participated in AS markets have been industrial loads and/or grandfathered in from previous under frequency relay load shedding programs (Todd et al 2008; Zarnikau 2010). The PJM regional transmission organization is the one market that has garnered significant new DR resource participation in AS (Cappers 2013). However, even there commercial sector loads have been slow to participate due to the uncertainties discussed.

Commercial building loads make up approximately 36% of the total electricity load in the United States (D&R 2012). Additionally, many commercial buildings have advanced native control systems that can be leveraged to respond to grid signals in an automated fashion (Kiliccote, Piette and Hansen 2006). Previous studies have examined the feasibility of using commercial building loads to provide such services (Rubinstein et al. 2009; Hao et al. 2013), but building management systems (BMS), the systems that control end-uses such as lighting and HVAC in a commercial building, have no defined interoperable communication path native to their design. The OpenADR Alliance has developed one solution to the communications issues to allow the scalability of demand response for AS without locking the resource into proprietary communications networks, the open standard data format OpenADR 2.0b.

Open Automated Demand Response (OpenADR) is a carrier agnostic, machine-readable messaging format to enable interoperable communication between grid operators and demand response resources. It employs a hierarchical architecture in which virtual top nodes (VTN) push or allow polling of information to virtual end nodes (VEN). Typically, the VTN is a demand response automation server (DRAS) that is receiving reliability, price or power instruction signals from grid operators that are then passed down to clients VENS that are either at the load directly or at load aggregators who can then disaggregate the signal to load sites below them. The 2.0 data format has become a national standard through National Institute of Standards & Technology's Smart Grid Interoperability Panel (Holmberg et al. 2012). There are currently two profiles available of the standard 2.0a and 2.0b. 2.0b was specifically designed to be able to handle advanced DR capability such as ancillary services communication, both signal receipt and reporting telemetry.

This project attempts to demonstrate a scalable architecture for interoperable communications to demand response resources for ancillary services using the OpenADR 2.0b standard data format. To show that DR can provide both types of market-based ancillary services, two independent test were run. This paper describes two separate commercial building-type sites, a Walmart Big Box Retail Store and a VFD-retrofitted HVAC supply fan, that provide different ancillary services (synchronous reserves and regulation) using OpenADR-based communications architectures in the PJM territory. It begins with a discussion of the demonstration design at each site. It goes on to describe the results of performance tests conducted at each site, focused primarily on speed of response and latency in the architecture, but also examining the precision of response in the regulation context. Lastly, it discusses the market value of the services and the energy impacts of providing them to candidate sites. The results of this work are intended to reduce the uncertainties of provision of ancillary services from demand response for grid operators and DR resource owners alike, as well as demonstrate the capability of the OpenADR 2.0b profile communications architecture. Due to the different circumstances of the testing environments and timeline, the results presented are of differing levels of detail and completeness. Specifically, while multiple frequency tests were performed and analyzed for the present paper, the synchronous reserves test reports on only a single test. More tests have since been conducted and will be discussed in later publications.

Demonstration Design

Two separate locations were chosen to test OpenADR 2.0b compliant communications platforms to provide ancillary services. The first site used lighting and HVAC loads in a big box retail store to provide synchronous reserves. The second site was in a laboratory in which a supply fan for a small heat pump was retrofitted with a variable frequency drive to provide frequency regulation. The first was chosen to showcase OpenADR's readiness to provide automated response that was observable from site-level telemetry, represents a significant load sector, and that could be relatively easily imbedded into building operations. The second site provided a highly controllable demonstration that allows for careful quantification of performance characteristics for the more demanding regulation service.

Synchronous Reserve Test Setup

The synchronous reserves test was performed once in October. The participating retail store was a Walmart in Pennsylvania. Roof top air conditioning units and interior perimeter lighting were shed in response to a test reserves call from PJM. The signals were comprised of instructions to shed different levels of load corresponding to the sheddable load of the two subsystems under control. The signaling architecture is shown in Figure 1.

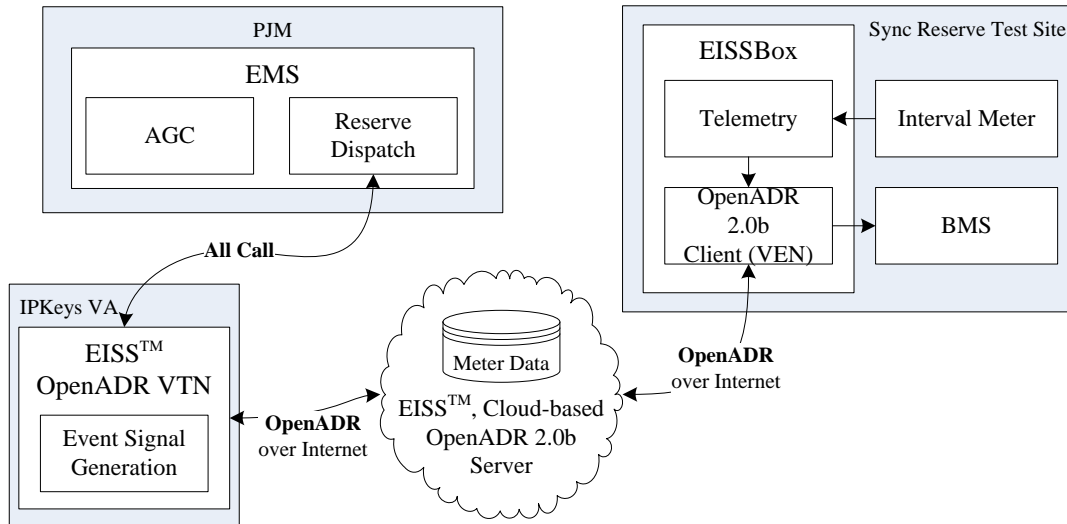

Figure 1. Communications architecture for Synchronous Reserve Test

PJM’s test call was received by IPKeys Technologies, acting as the curtailment service provider (CSP). An event was created and pushed over HTTP using IPKeys’ OpenADR2.0b compliant Energy Interop™ Server and System (EISS™) to their cloud based server, from a VTN to VTN. The server is polled every twenty seconds by the receiving client onsite, which is connected to the internet via a cellular network. The client closes a dry contact relay connection with the BMS to initiate the load control actions.

In the synchronous reserve pilot, the control strategy involved two systems: lighting and HVAC. For the lighting system, one third of the interior lighting in the retail space was shut off in response to the sync reserve events; this involved automated switching of the breakers which controlled those lights. The HVAC system responded to control through setpoint adjustment.

Meter data was collected and aggregated to one minute intervals via a telemetry link through the EISS™ system. The power data reported has been scaled based on the load in the 1-minute interval immediately prior to the shed request to protect information that could be construed as a competitive advantage of the store. From this data we can see relative percentage load drops and roughly the amount of time before load responds to the signal.

Frequency Regulation Test Setup

The frequency regulation tests were performed with a VFD-retrofitted heat pump supply fan that cools a small laboratory at a Schneider Electric facility in North Carolina. The VFD can drive a previously constant volume fan within a range of +/- 5 hertz in 0.5 Hz steps. To run the tests, normalized regulation signals were sent via OpenADR and translated into the frequency range in which device operates. In this scenario, the model for translating the frequency range resides in the EISSBox, although for scalability the control logic should be migrated to the PLC or ultimately a BMS for a true deployment in a commercial building. Additionally, the controller is open loop with respect to its objective, power.

The communications architecture for the frequency regulation test is shown below in Figure 2. IPKeys receives DNP3 signals from PJM’s EMS with a two-second frequency. These

signals are translated and the OpenADR VTN creates events that are sent to the cloud-based server. However, for the test performed, the connection to PJM’s EMS had not been made so that the latency caused by the DNP3 translation could not be captured in the tests. Instead, the EISS™ VTN created events based on PJM’s publicly available regulation data. IPKeys employs the same signaling, however to make sure that latency is minimized, the connection to the internet is hardwired through the site’s network. Additionally, the VFD controller required a Programmable Logic Controller (PLC) in order to interface with the EISSBox. This PLC also serves as the connection to the meter.

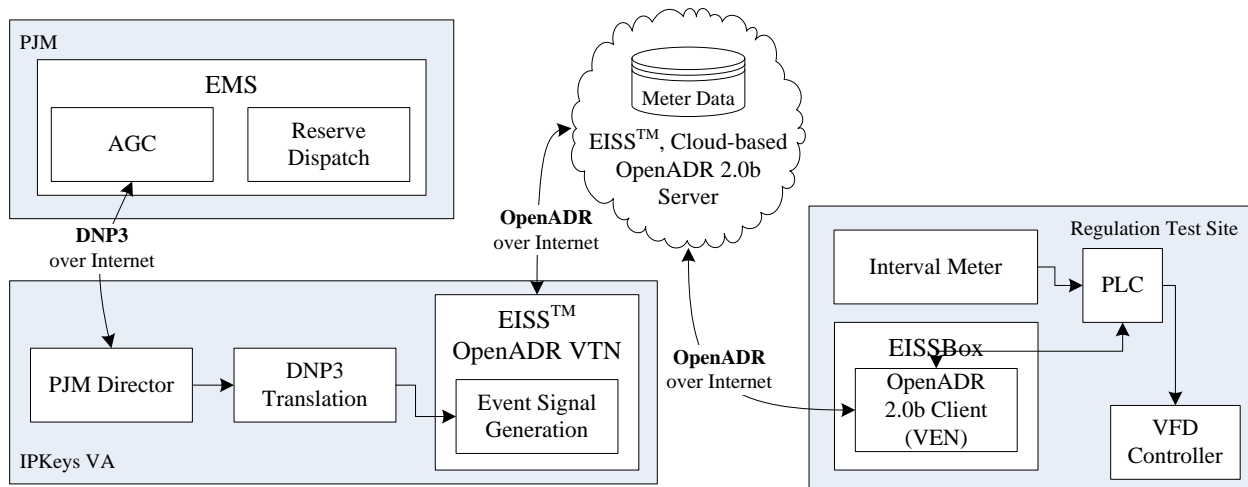

Figure 2. Communications architecture of the regulation reserves demonstration

Results and Discussion

Synchronous Reserve Demonstration Response

The synchronous reserve demonstration consisted of a single end-to-end test in which PJM used their all call method to initiate a synchronous reserve deployment. PJM sent three signals corresponding to different subsystems to shed. The first signal initiated the lighting shed at 6:17 PM UTC, the second initiate the HVAC shed at 6:23 PM UTC, and the final signal ended the response event at 6:32 PM UTC, all measured at receipt at the event signal generator. The signal time and reserve response is shown below in Figure 3. To protect the potential competitive advantage of Walmart’s energy data, the figure is scaled relative to the energy output of the system right before the synchronous reserve deployment occurred. Shortly after the reserve was called, the energy output dropped approximately 2%, corresponding to the shed of the perimeter lighting. After the second call, another 4% for a total of 6% is shed. It is difficult to understand the speed of the shed exactly. It appears it took at least 2 minutes to shed the lights based on the number of data points past the beginning of the reserve call as measured by the site electricity meter. The HVAC shed appears to either occur slightly before the reserve call suggesting there may be a time synchronization issue in the dataset. The trajectory of the load immediately following a return

to normal operations appears to be consistent with before the shed, implying no significant load rebound as a result of responding to such a short event.

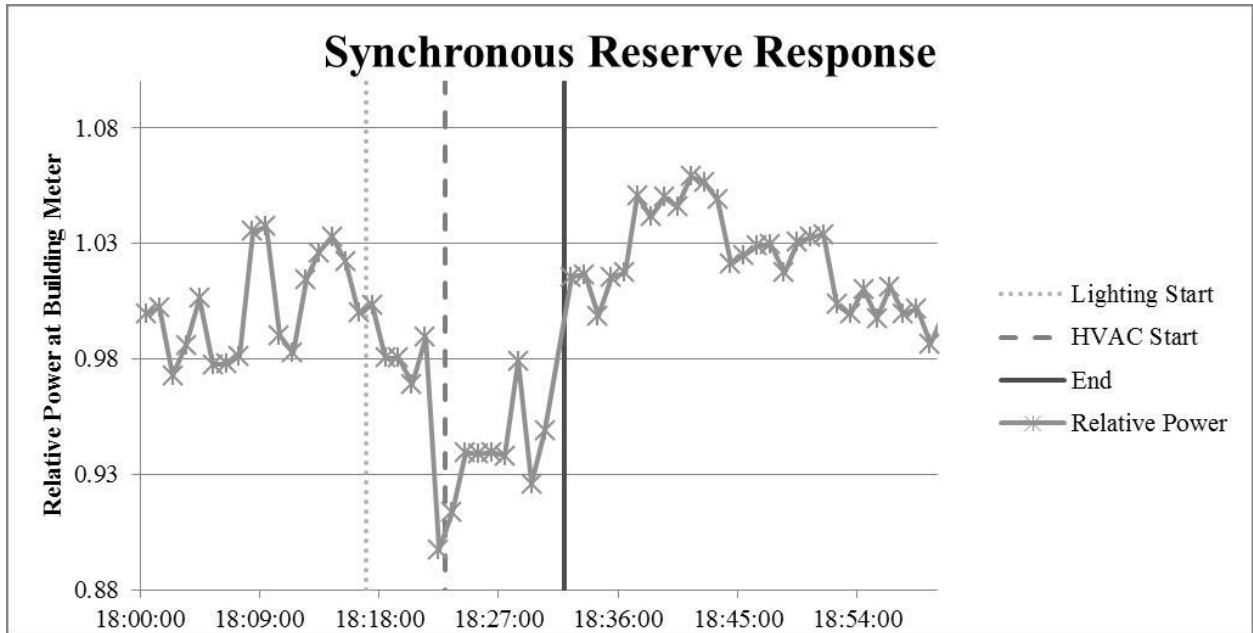

Figure 3. Relative response from synchronous reserve test at Walmart store

This preliminary demonstration is successful in showing that commercial building load response managed through a central BMS can react with adequate speed to respond to synchronous reserve events. Further tests with PJM’s new automated reserve calling system are planned to show an end-to-end automated response to reserve requests and repeatable responses.

Regulation Demonstration Results

A demonstration of regulation capability from a variable frequency driven fan on a small heat pump was performed to characterize the latency and response characteristics of an OpenADR 2.0b-enabled demand response resource. To accomplish this, a relationship between fan frequency and power was obtained through repeated step response tests. This was followed by a characterization of the speed of response by testing the time to get from minimum to maximum load. Finally to test actual regulation capability, the resource was asked to follow PJM’s self-test for regulation certification for their faster frequency regulation signal, RegD. The resources performance was evaluated using the precision metric used by PJM for certification. Data collected from each of these tests was used to examine the statistical properties of the latency in the communications architecture.

Characterizing frequency response of the VFD

The native control for a VFD is interested only in maintaining the rotational speed of the device it is controlling. However, the goal of a resource providing regulation is to follow a power signal. Thus, to control a VFD, there must be some method to map the power that is

requested to frequency for control. To develop this model, a series of 0.5 Hz step tests were run across the controllable frequency range. The resulting power measurements¹ were recorded and are shown in Figure 4.

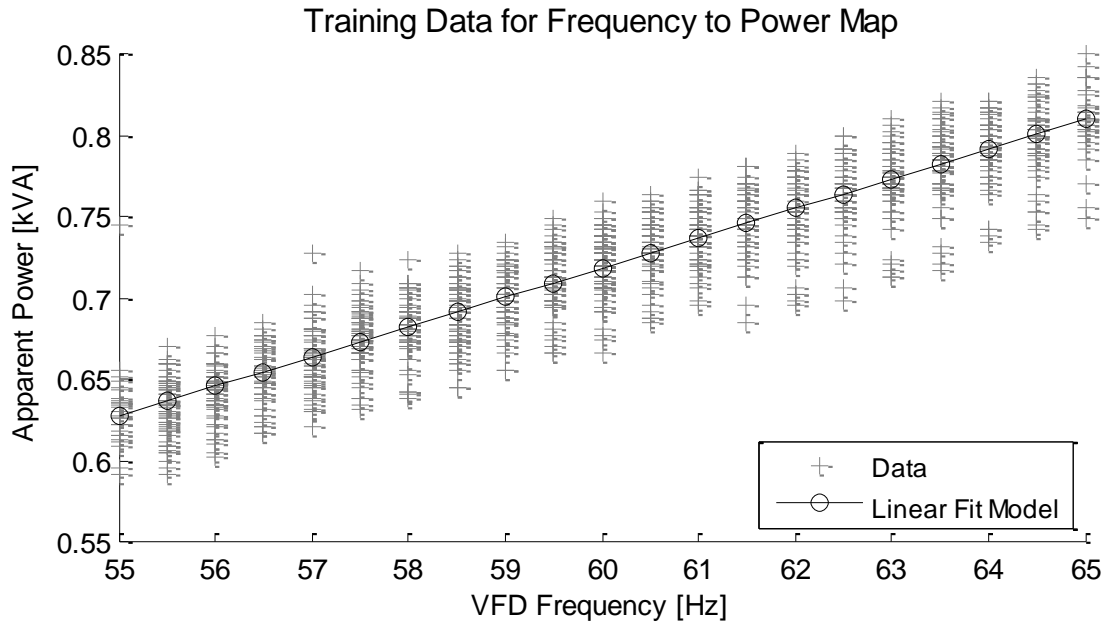

Figure 4: VFD frequency measurement to apparent power

From the data, a linear model can be deduced to quantify the relationship between frequency and apparent power. Using a simple linear regression, the resulting model is: $\text{apparent power [kVA]} = 0.0181 * \text{frequency} - 0.3731$ with a root mean squared error of 0.0197 kVA and an r^2 of 0.87. While the error is relatively large compared to the resulting resource size of 0.09 kVA, the fit appears strong enough to proceed with other tests. The use of a linear model for speed to power is counter intuitive, as centrifugal fan power is generally related to fan speed by an exponential (DOE 2012). As the results clearly suggest a linear approximation, this inconsistency may be due to only reporting apparent power, or to the limited frequency range tested for this application.

Communications latency

Latency in the architecture of this experiment is defined as the difference between the time that an event signal is created by the IPKeys systems upon receipt of instructions from PJM to the time that OpenADR formatted event arrives at the client. Table 1 below summarizes the data collected from every test performed on the system.

Table 1: Summary of communications latency statistics

Number of signals sent	1538
------------------------	------

¹ Due to limitations in metering infrastructure, power factor could not be observed for the fan controlled by the VFD, thus only apparent power in kVA is reported here, although it is treated as though it were power for the purposes of analysis.

Number of signals received	1495
Signals lost	43
Minimum latency [s]	0.01
25th percentile latency [s]	0.29
Median latency [s]	0.44
75th percentile latency [s]	1.04
Maximum latency [s]	10.21
Average latency [s]	0.99

Average latency is very nearly one second; however a closer look at the data shows that 75% of the latency measurements are less than 1.04 seconds, implying that a few large measurements significantly biased the average. As PJM's performance measure for following regulation signals is a ten second delay in response, the architectural latencies described here appear acceptable (PJM 2013a). This does not yet account for any latency in the signal transmission from PJM or the translation of the DNP3 signal to OpenADR. Future tests will include this connection directly to PJM's systems and quantify the additional latency, if any.

Speed of response

The lag between the receipt of the signal at the OpenADR client and the resulting change in power read by the meter is defined as the speed of response. This includes signal receipt, translation to Modbus, BACnet, or any other BMS protocol, running the control logic, and the lag between control action and measured response.

To test this parameter, the VFD was commanded to step between its basepoint at 60Hz, its min at 55 Hz, and its max at 65 Hz. Each step was commanded to hold the output for five minutes, so that the resource could settle into steady state operation. Figure 5 shows the signal and metered response with respect to time for the tests. The response to the steady state hold suggests that there is a bias in the metered response which may be indicative of improper fit in the linear model.

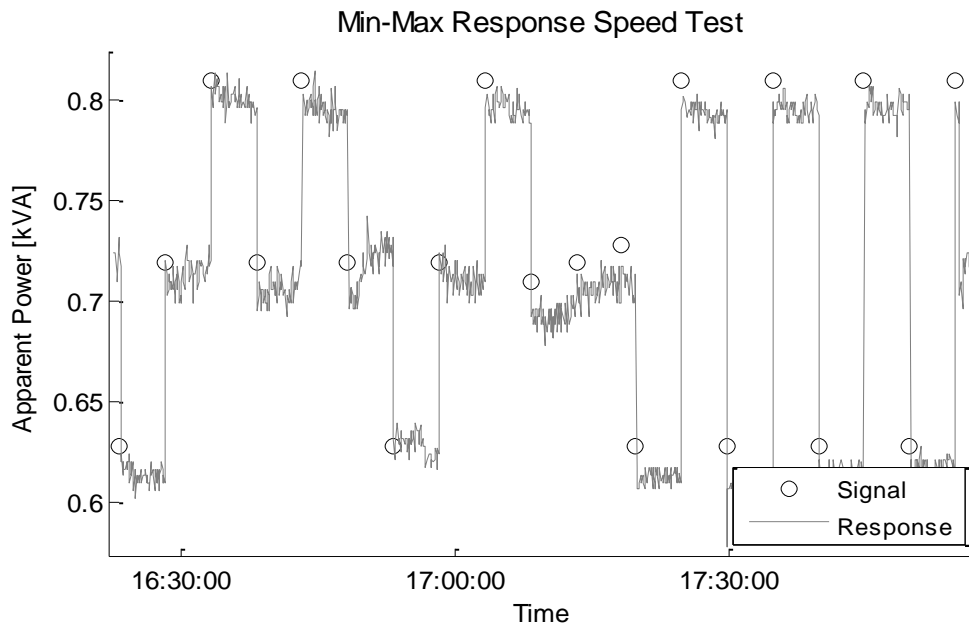

Figure 5. Response Speed Tests

In order to capture the speed of response, the difference between the time that the signal was received and when the response was within a band of twice the root mean squared error around the expected value was recorded. The average speed of response of the 18 data points was 4.66 seconds. This value varied between 2.28 and 7.23 seconds. However, since the meter data was recorded at roughly four second intervals, it is difficult to say whether or not that the true average value, if metering occurred at the instant of change in power, would be nearer the low or high end of that spectrum.

Accuracy of response

To measure the accuracy of response, a test of the system attempting to follow PJM's published self-test signal for regulation resource certification was used. PJM has two types signals for regulation, the traditional (RegA) for slower resources and the dynamic (RegD) for faster responding resources. The test signal used is a 40-minute dynamic regulation signal, shown below in Figure 6, designed to be representative of actual conditions a resource may face when providing the service. Figure 6 also includes the response of the VFD to the signal. While the self-test signal is a continuously variable, normalized signal between -1 and 1, the VFD is capable of making adjustments to frequency in 0.5 Hz increments, and thus must round the resulting mapped frequency to the nearest 0.5 Hz step, causing some of the error visible in the response.

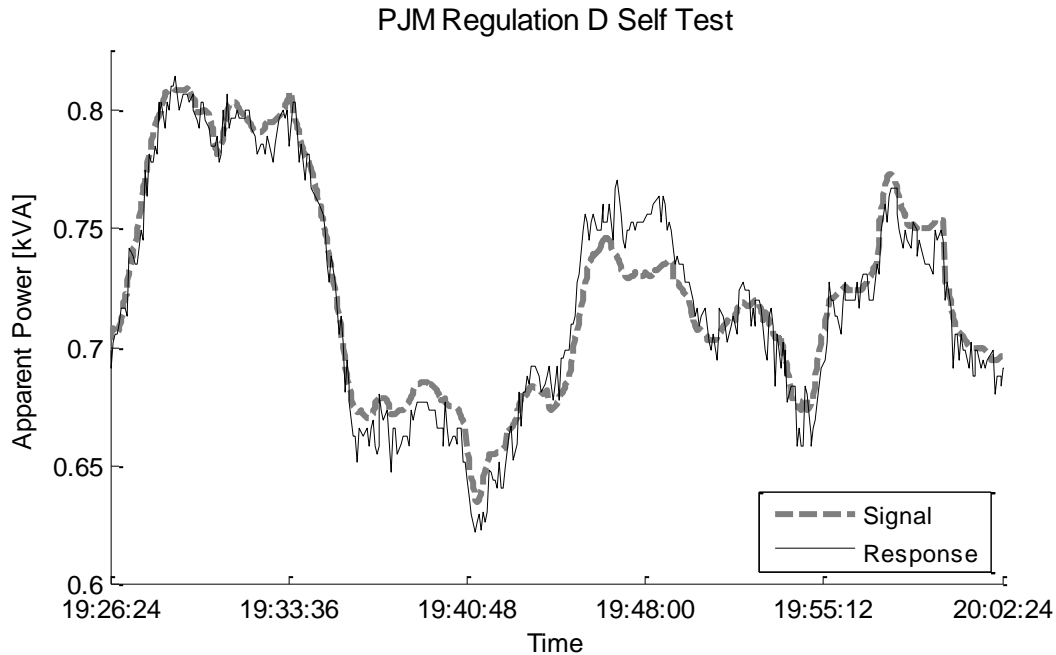

Figure 6: VFD response to the PJM self-test for fast regulating resource certification

The precision metric described in PJM’s Manual for Balancing Operations was used to evaluate the performance of the system. Precision is the probabilistic inverse of error. Error is described as the average of the absolute value of the difference between the energy of the regulation signal and the response, measured in 10s increments. This is then divided by the average regulation signal over the interval (PJM 2013a). For the response shown in Figure 6, the VFD response’s performance was 90%. The target for certification as a resource is 75% performance or better, so by this metric of performance the VFD load response is a success.

Business Impacts

There is considerable uncertainty among building energy managers in the actual operational impacts of providing demand response. In the case of DR for AS the impact on the end-use utility, relating to how much is required of the resource and how often it’s called, along with the resource’s compensation are of particular concern. This discussion attempts to show what the operational energy impacts that AS provision in PJM may have on the demand response resource owner and discuss the potential market value through analysis of historical data.

Market Value

PJM splits its Synchronous Reserve Market into two tiers. Tier 1 reserves are those that result from economically dispatching generation at levels less than their rated capacity. Tier 1 resources are not paid for their capacity, as they have no lost opportunity cost; however, they receive a premium on the price of energy they supply during reserve events. Tier 2 resources are those resources that are dispatched for energy at a sub-optimal level in order to maintain adequate reserve in the system. These resources do have a lost opportunity for supplying

energy and are thus paid a capacity price that is equivalent to the largest opportunity cost payment of all such resource, termed the market clearing price (MCP). Tier 2 resources are only called if there is insufficient capacity in Tier 1 to meet reserve requirements and are cleared on an hourly basis in the real-time market (PJM 2013a).

Demand Response is considered a Tier 2 resource, although it does not have an opportunity cost in the same way a generator might. Thus a DR resource relies on other, more traditional Tier 2 resources to set the market clearing price for synchronous reserves. To get a sense of the range of prices for synchronous reserve, analysis of historical data may be useful. Table 2 displays market clearing price statistics for synchronous reserves in PJM’s Mid Atlantic Reserve Zone in 2013 taken from publicly available data (PJM 2014a). The data suggests that if a demand response resource was available for all hours of a month, then the resource may expect to capture \$2.24 per kW of DR capacity per month. However, the spinning reserve MCP is the most uncertain of the AS prices in PJM, as evidenced by the very large standard deviation and the fact that 54% of hours recorded a market clearing price of zero. A more thorough analysis would consider only the value during the hours in which a DR resource is available to shed load, such as during business hours for lighting and HVAC in a retail store. This value is also only inclusive of the capacity value of providing synchronous reserve, this does not include the value of the energy provided when called, which is paid at the locational marginal price plus \$0.05/kWh.

Table 2. Market Clearing Price Statistics for PJM AS in 2013

Units = [\$/MW-h]	Average	Std Dev	Min	Max	MCP = \$0
MCP for Synchronous Reserve*	3.06	8.63	0.00	210.07	54.0%
MCP for Capacity (Regulation)	24.02	28.74	0.00	756.05	0.1%
MCP for Performance (Regulation)	4.12	2.52	0.00	29.14	2.5%

* For PJM Mid Atlantic Reserve Zone Only

In addition to the value available for synchronous reserve, Table 2 also contains data pertaining to the value of regulation during 2013. The average market clearing price suggests that the capacity value to a resource that can provide regulation for all hours of the day is approximately \$17.5/kW-mo. This is considerably higher than the value of synchronous reserve and the clearing price has less uncertainty with very few hours in the year clearing at \$0/MW-h. Additionally, resources earn additional revenue from their performance each hour, which is tied to the market clearing price for performance. The nearly order of magnitude difference in the value of regulation suggests that resources that have the control and metering capability should give significant consideration to participation in regulation in PJM’s markets.

Energy Impacts: Frequency and Duration of Events

A common concern of potential demand response participants in ancillary services markets is what impact participation will have on their operations. One way to examine this would be to consider the frequency or probability to be called in any hour as well as the duration of response required.

Historical synchronous reserve data from the last five years suggest that on average, PJM calls synchronous reserve calls in their Reliability First Corporation Reserve Zone an average of 31 times per year, with a range of 19 to 39 reserve deployments per year (PJM 2014b). This corresponds to a roughly 0.4% probability that awarded capacity will be called in any given hour. Additionally, the average duration of events in these five years was 11 minutes and 18 seconds, with a standard deviation of the sample around 7 minutes. The minimum duration was 4 minutes and the maximum was 1 hour and 8 minutes. These statistics suggests that 80% of reserve calls in PJM are less than 20 minutes in length. This makes synchronous reserves in PJM look much less impactful than traditional emergency demand response programs that typically have 2-4 hour response durations and can be called for upwards of 100 hours per year (Cappers et al. 2012). In terms of impact to building operations, Synchronous reserve appears to be a better option than most traditional DR programs as long as the building management system is capable of receiving a response request and shedding load within the ten minutes required.

Resources providing regulation will be actively following the automatic generation control signal during all hours of their award period. To examine the energy impacts this may have, normalized sample regulation data corresponding to the historical fast regulation signal for the PJM system was analyzed (PJM 2013b). Total energy generation (or energy shed in the case of DR) was calculated over three different rolling time horizons: five minutes, fifteen minutes, and one hour. The energy generated relative to the capacity of the resource is reported in Table 3. It suggests that over a five minute period, the average energy consumption due to regulation was an increase of approximately 0.5% of its capacity. This seems to be roughly true of all time horizons. The maximum energy shed over five minutes, however, shows the possibility of nearly 100% of capacity being utilized. As the time horizon increases, the maximum observed energy shed reduces to 28.5% of capacity, indicating that the very rare five minute max excursions do not have significant impacts on longer time horizons for energy generation due to regulation for the fast regulation signal in PJM.

Table 3. Energy generation or consumption while providing frequency regulation*

Time Horizon	Energy Generation [kWh/kW]			
	Average	Std Dev	Min	Max
5 min	-0.0004	0.019	-0.083	0.083
15 min	-0.0013	0.026	-0.212	0.178
1 hour	-0.0054	0.043	-0.253	0.285

*From PJM public data from mid-December 2012 to mid-January 2013 (PJM 2013b)

Conclusions and Future Work

Demand response resources show great promise as a provider of ancillary services. The present work describes a battery of tests that show adequate capability of HVAC and lighting loads to provide ancillary services in the PJM Interconnection territory. The synchronous reserve test displayed noticeable load sheds for both the lighting system and the HVAC system within a few minutes of receiving the signal. For both load drops, the response was

much faster than the ten minutes required by the synchronous reserve product definition and supports the notion that automated demand response of HVAC and lighting in retail stores is a viable synchronous reserve resource.

Regulation is a much faster product requiring more comprehensive analysis. Tests were performed to characterize the power to frequency relationship, gain an understanding of the speed of response of the system, and evaluate the accuracy of signal following that the VFD could achieve with very simple open loop power control. With an average overall system response time of approximately five seconds, the latencies and the speed of response in the OpenADR certified communications architecture provided by IPKeys Technologies were low enough to make the open standard an adequate solution for demand response communications providing frequency regulation when utilizing an XMPP push protocol. Additionally, the VFD was able to follow the PJM self-test dynamic regulation signal with a precision of 89%. Coupled with the demonstrably fast speed of response, the system's performance score in PJM's market should well exceed the 75% required for resource certification. This suggests that VFD-enabled loads communicating using OpenADR 2.0b can successfully provide frequency regulation to PJM. The paper also analyzed both the value and the energy impacts of providing these products. Regulation capacity was nearly an order of magnitude more valuable at \$24/MW-h and that value was less uncertain than synchronous reserves, valued at an average of \$3/MW-h with more than 50% of hours with no value in the PJM markets. As far as energy impacts are concerned, both regulation and synchronous reserves are very low impact. Historical data suggests that synchronous reserves have a 0.4% probability of being called and that even when they are called it is for 11 minutes on average. While regulation is a product that is used most of the time, the nature of the signal means that there is a very limited energy impact while providing the service. Over 5 minute, 15 minute, and one hour time scales, regulation only converted approximately 0.5% of the capacity awarded to energy when resources were following PJM's dynamic regulation signal.

The research presented is still ongoing, and there is hope that it will be augmented with additional data and end-to-end integration with PJM's systems for further testing.

Additionally, future work is planned to expand the scalability of the DR for AS solution described in the following areas:

- While we have shown that the OpenADR platform can be adequately employed to enable individual sites to provide ancillary services, these sites are not actually large enough to participate in the market on their own. The next step is to demonstrate the coordination of an aggregation of resources to respond to AS signals.
- The regulation test signal controls in the present study need further development. A demonstration in which the control logic embedded into the BMS of a test site would provide a scalable demonstration that includes a more realistic response time. Additionally, the control loop currently is open loop with respect to its objective, a specified power output. Feedback and more advance logic should be added to the control design to improve accuracy of the system's response.

Acknowledgements

The authors would like to acknowledge our partners at Wal-Mart Stores, Inc., Schneider Electric, IPKeys Technologies, Inc, and PJM. Specifically, we'd like to thank Angie Beehler, Bob Stone, Christine Bush, Jo Lockard, Scott Coulter, Tim Heckman, Rob Nawy, Bob

Womack, and Joe Callis. The work described in this paper was coordinated by the Consortium for Electric Reliability Technology Solutions and was funded by the Office of Electricity Delivery and Energy Reliability, Transmission Reliability Program of the U.S. Department of Energy under Contract No. DE-AC02-05CH11231.

References

- Callaway, D. 2009. "Tapping the energy storage potential in electric loads to deliver load following and regulation, with application to wind energy." *Energy Conversion and Management* 50 (5): 1389-1400
- Cappers, P., A. Mills, C. Goldman, R. Wiser, and J. H. Eto. 2012. "An assessment of the role mass market demand response could play in contributing to the management of variable generation integration issues." *Energy Policy* 48: 420-429.
- Cappers, P., J. MacDonald, C. Goldman, and O. Ma. 2013. "An assessment of market and policy barriers for demand response providing ancillary services in US electricity markets." *Energy Policy* 62: 1031-1039.
- DOE (Department of Energy). 2012. EnergyPlus Documentation: Engineering Reference Prepared for: Building Technologies Program, Energy Efficiency and Renewable Energy, U.S. Department of Energy. http://apps1.eere.energy.gov/buildings/energyplus/energyplus_documentation.cfm
- D&R (D&R International, Ltd.). 2012. *2011 Buildings Energy Data Book*. Prepared for: Building Technologies Program, Energy Efficiency and Renewable Energy, U.S. Department of Energy. <http://buildingsdatabook.eren.doe.gov/default.aspx>
- FERC. 1996. *Order 888: Promoting Wholesale Competition Through Open Access Non-discriminatory Transmission Services by Public Utilities*.
- FERC. 2008. *Order 719: Wholesale Competition in Regions with Organized Electric Markets*
- FERC. 2011. *Order 755: Frequency Regulation Compensation in Organized Wholesale Power Markets*.
- FERC. 2012. *Order 764: Integration of Variable Energy Resources*.
- Hao, H., A. Kowli, Y. Lin, P. Barooah, and S. Meyn. "Ancillary service for the grid via control of commercial building hvac systems." In *American Control Conference (ACC), 2013*, pp. 467-472. IEEE, 2013.
- Helman, U. 2010. "Resource and transmission planning to achieve a 33% RPS in California—ISO modeling tools and planning framework." In *FERC Technical Conference on Planning Models and Software*.

- Holmberg, D., G. Ghatikar, E. Koch, and J. Boch. 2012. "OpenADR Advances." *ASHRAE Journal* 54 (11).
- Kiliccote, S., M. A. Piette, and D. Hansen. 2006. "Advanced Controls and Communications for Demand Response and Energy Efficiency in Commercial Buildings." In *Second Carnegie Mellon Conference in Electric Power Systems*. Pittsburgh, PA.
- Kirby, B. J. 2007. "Load response fundamentally matches power system reliability requirements." In *Power Engineering Society General Meeting*, IEEE, pp. 1-6.
- Ma, O., N. Alkadi, P. Cappers, P. Denholm, J. Dudley, S. Goli, M. Hummon et al. "Demand Response for Ancillary Services." (2013): 1-8
- MacDonald, J., P. Cappers, D. Callaway, and S. Kiliccote. 2012. "Demand Response Providing Ancillary Services: A Comparison of Opportunities and Challenges in US Wholesale Markets." In *Grid-Interop 2012*. Irving, TX.
- PJM. 2012. *Regulation Self Test Signals: RegD Test Wave*. Accessed February 2014 <http://www.pjm.com/~media/markets-ops/ancillary/regd-test-wave.ashx>
- PJM (PJM Interconnection). 2013a. *PJM Manual 12: Balancing Operations*. Rev: 30. <http://www.pjm.com/~media/documents/manuals/m12.ashx>
- PJM. 2013b. *Fast Response Regulation Signal*. Accessed March 2014 <http://www.pjm.com/markets-and-operations/ancillary-services/mkt-based-regulation/fast-response-regulation-signal.aspx>
- PJM. 2014a. *Preliminary Billing Reports p Ancillary Services Market Data*. Accessed February 2014 <http://www.pjm.com/markets-and-operations/market-settlements/preliminary-billing-reports.aspx>
- PJM. 2014b. *Historical Synchronized Reserve Events*. Accessed March 2014 <http://www.pjm.com/~media/markets-ops/ancillary/historical-spin-events.ashx>
- Rubinstein, F., L. Xiaolei, and D. S. Watson. 2010. *Using Dimmable Lighting for Regulation Capacity and Non-Spinning Reserves in the Ancillary Services Market: A Feasibility Study*. Berkeley, CA: Lawrence Berkeley National Laboratory.
- Todd, D., M. Caufield, B. Helms, Alcoa Power Generating, Inc, M. Starke, B. Kirby, and J. Kueck. 2008. *Providing reliability services through demand response: A preliminary evaluation of the demand response capabilities of alcoa inc*. Oak Ridge, TN: Oak Ridge National Laboratory.
- Zarnikau, J. W. 2010. "Demand participation in the restructured Electric Reliability Council of Texas market." *Energy* 35 (4): 1536-1543.