

ERNEST ORLANDO LAWRENCE
BERKELEY NATIONAL LABORATORY

LBNL Report

Potential Global Benefits of Improved Ceiling Fan Energy Efficiency

Nakul Sathaye, Amol Phadke**, Nihar Shah, Virginie Letschert

** Corresponding author: aaphadke@lbl.gov

Environmental Energy Technologies Division

October 2012

This work was funded by the Bureau of Oceans and International Environmental and Scientific Affairs, U.S. Department of State, and administered by the U.S. Department of Energy in support of the Super-efficient Equipment and Appliance Deployment (SEAD) initiative through the U.S. Department of Energy under Contract No. DE-AC02-05CH11231

Disclaimer

This document was prepared as an account of work sponsored by the United States Government. While this document is believed to contain correct information, neither the United States Government nor any agency thereof, nor The Regents of the University of California, nor any of their employees, makes any warranty, express or implied, or assumes any legal responsibility for the accuracy, completeness, or usefulness of any information, apparatus, product, or process disclosed, or represents that its use would not infringe privately owned rights. Reference herein to any specific commercial product, process, or service by its trade name, trademark, manufacturer, or otherwise, does not necessarily constitute or imply its endorsement, recommendation, or favoring by the United States Government or any agency thereof, or The Regents of the University of California. The views and opinions of authors expressed herein do not necessarily state or reflect those of the United States Government or any agency thereof, or The Regents of the University of California.

Ernest Orlando Lawrence Berkeley National Laboratory is an equal opportunity employer.

ACKNOWLEDGEMENTS

Michael McNeil and Jing Ke of Lawrence Berkeley National Laboratory provided support for the BUENAS modeling effort. Daljit Singh and Adwait Pednekar of Prayas Energy Group provided a lot of the underlying data, as well as insights and comments on the draft article. Steve Pantano and P.K. Mukherjee at the Collaborative Labeling and Appliance Standards Program (CLASP), Abigail Daken at the US Environmental Protection Agency, Gabrielle Dreyfus at the US Department of Energy, and Won Young Park at the Lawrence Berkeley National Laboratory provided helpful comments and suggestions. Any errors or omissions are the authors' own.

ABSTRACT

Ceiling fans contribute significantly to residential electricity consumption, both in an absolute sense and as a proportion of household consumption in many locations, especially in developing countries in warm climates. However, there has been little detailed assessment of the costs and benefits of efficiency improvement options for ceiling fans and the potential resulting electricity consumption and greenhouse gas (GHG) emissions reductions. We analyze the costs and benefits of several options to improve the efficiency of ceiling fans and assess the global potential for electricity savings and GHG emission reductions with more detailed assessments for India, China, and the U.S. We find that ceiling fan efficiency can be cost-effectively improved by at least 50% using commercially available technology. If these efficiency improvements are implemented in all ceiling fans sold by 2020, 70 terrawatt hours per year (TWh/year) could be saved and 25 million metric tons of carbon dioxide (CO₂) emissions per year could be avoided, globally. We assess how policies and programs such as standards, labels, and financial incentives can be used to accelerate the adoption of efficient ceiling fans in order to realize this savings potential.

Keywords: Ceiling fan, Efficiency, Residential, Bottom-up, Standards and labeling, Financial incentives

Please use the following citation for this report

Nakul Sathaye, Amol Phadke, Nihar Shah, and Virginie Letschert (2012). Potential Global Benefits of Improved Ceiling Fan Energy Efficiency, LBNL, Berkeley. LBNL-###

TABLE OF CONTENTS

ABSTRACT	ii
Acronyms	1
Executive Summary	3
1. Introduction.....	1
2. Technological-economic assessment of efficiency improvement options in ceiling fans.....	4
2.1. Measuring ceiling fan performance	4
2.1.1. Efficiency and efficacy.....	4
2.1.2. Treatment of fan performance in standards and labeling programs	5
2.2. Efficiency improvement options for ceiling fan systems.....	6
2.2.1. Fan motors	7
2.2.2. Fan blades.....	9
2.2.3. Fan efficiency improvement opportunities: Empirical evidence from the US market.....	11
2.3. Technical and Economic analysis of Efficiency Improvement Options	14
2.3.1. Fan motors	14
2.3.2. Fan blades.....	15
2.3.3. Cost of conserved electricity	16
2.3.4. Sensitivity of Cost-Effectiveness Analysis.....	18
3. Energy Savings Potential	19
3.1. Data and Methodology	20
3.2. Results.....	24
3.2.1. Business-As-Usual.....	24
3.2.2. Efficiency Scenario.....	25
4. Ancillary Benefits of Fan Efficiency Improvement	29
5. Realizing cost-effective efficiency improvements: lessons for market transformation programs	31
5.1. General Insights.....	31
5.2. Standards and Labeling Programs	32
5.3. Incentive Programs	34
6. Conclusions.....	35
Appendix A. Fan Laws.....	44

Appendix B. Heat Transfer and Thermal Comfort	47
Appendix C. Effect of Fan Speed on Efficacy	49
Appendix D. Cost of Conserved Electricity Results	52

TABLE OF FIGURES

Figure 1 Ceiling Fan Components	5
Figure 2 Efficacy of ENERGY STAR ceiling fans (fan and light combination devices) at high speed	5
Figure 3 Potential electricity savings resulting from introduction of efficient fans, 2000-2030	8
Figure 5 BEE (India) star labels compared to estimates of potential ceiling fan efficacy.....	Error!
Bookmark not defined.	
Figure 6 Sensitivity Analysis of Cost Effectiveness of Incentive Programs in India, assuming 50% power savings.	Error! Bookmark not defined.
Figure 7 Ceiling Fan System Components	6
Figure 8 Design drawings from a patent for a ceiling fan with twisted, tapered blades with an airfoil. The first drawing is of the whole fan, and the second is a side view of a blade.	10
Figure 9 Efficacies for ENERGY STAR ceiling fans (fan only, without lights) at high speed ...	12
Figure 10 Efficacies for ENERGY STAR ceiling fans fan plus light combination)	13
Figure 11 Costs of a controller for a BLDC Motor based on components, (Chiang, 2010).....	15
Figure 12 Sensitivity Analysis of Cost Effectiveness of Incentive Programs in India, assuming 50% power savings.	19
Figure 13. Global Electricity Consumption of Ceiling Fans by Country in 2012	25
Figure 14. Potential electricity savings resulting from introduction of efficient fans, 2000-2030	28
Figure 15. Potential CO2 emissions reductions resulting from introduction of efficient fans, 2000-2030	28
Figure 16. BEE (India) star labels compared to estimates of potential ceiling fan efficacy.....	33
Figure 17 Efficacy Versus Fan Speed.....	49

TABLE OF TABLES

Table 1 Incremental manufacturing costs, annual energy savings and CCE for various efficiency improvement options in ceiling fans in India	7
Table 2 Summary of characteristics used in various standards and labeling programs.....	5
Table 3 Efficiency data for various 75-W motor types in the U.S.	8
Table 4 Summary of power consumption of efficient fans using various options	13
Table 5. Summary of the reported manufacturing costs of several efficiency improvement options.....	16
Table 6 Summary of reported manufacturing costs in dollars of efficiency improvement options	16
Table 7 Cost of conserved electricity for various efficiency improvement options in India.....	17
Table 8 Diffusion Parameters for Fans	21
Table 9. Stock of fans calculated in BUENAS, by country.....	22
Table 10. Fan usage characteristics used in BUENAS, by country.....	23
Table 11. Sales forecast for 2012, 2030 and annual projected growth rate	24
Table 12. Annual and cumulative energy savings forecasts.....	26
Table 13. Annual and cumulative GHG emissions reduction forecasts	27
Table 15 Ceiling fan similitude relationships, which provide proportional relation between design variables and performance characteristics.....	45
Table 16 Cost of Conserved Electricity for various efficiency options in the SEAD economies and China	52

Acronyms

AC	Alternating Current
AQSIQ	General Administration of Quality Supervision Inspection and Quarantine of the People's Republic of China
BAU	Business As Usual
BIS	Bureau of Indian Standards
BUENAS	Bottom Up Energy Analysis System
BLDC	Brush Less Direct Current
CCE	Cost of Conserved Electricity
CDD	Cooling Degree Days
CFM	Cubic Feet per Minute
CLASP	Collaborative Labeling and Appliance Standards Program
CO ₂	Carbon Dioxide
DC	Direct Current
EU	European Union
FP	First Purchase
GDP	Gross Domestic Product
GHG	Green House Gas
INR	Indian Rupee
kWh	kilo Watt hour
MEPS	Minimum Energy Performance Standards
MW	Megawatts, i.e.10 ⁶ Tons
MT	Megatons i.e.10 ⁶ Tons
NDRC	National Development and Reform Commission of the People's Republic of China
PV	Photovoltaic
RAC	Room Air Conditioner
REP	Replacement

SEAD	Super-efficient Equipment and Appliance Deployment Initiative
SEEP	Super-Efficient Equipment Program
TWh	Terawatt-hour i.e. 10^{12} Watt hours
UEC	Unit Energy Consumption
US DOE	United States Department of Energy
US EPA	United States Environmental Protection Agency
W	Watts

Potential Global Benefits of Improved Ceiling Fan Energy Efficiency

Nakul Sathaye, Amol Phadke, Nihar Shah, and Virginie Letschert

Energy Analysis Department, Environmental Energy Technologies Division,
Lawrence Berkeley National Laboratory, One Cyclotron Road, Berkeley, CA,
United States

Executive Summary

This report presents the results of an analysis, commissioned by the United States Department of Energy (US DOE), of ceiling fan efficiency. This analysis was prepared in support of the Super-efficient Equipment and Appliance Deployment (SEAD) initiative.¹ The International Energy Studies group at Lawrence Berkeley National Laboratory (LBNL) performed the analysis. The objective of this analysis is to provide the background technical information necessary to improve the efficiency of ceiling fans, and to provide a foundation for the voluntary activities of SEAD participating countries.

SEAD aims to transform the global market by increasing the penetration of highly efficient equipment and appliances. SEAD partners work together in voluntary activities to: (1) “raise the efficiency ceiling” by pulling super-efficient appliances and equipment into the market through cooperation on measures like incentives, procurement, and awards; (2) “raise the efficiency floor” by working together to bolster national or regional minimum efficiency standards and labels; and (3) “strengthen the efficiency foundations” of programs by coordinating cross-cutting technical analysis to support these activities.²

¹ An initiative of the Clean Energy Ministerial (CEM) and a task within the International Partnership for Energy Efficiency Cooperation (IPEEC), SEAD seeks to engage governments and the private sector to transform the global market for energy-efficient equipment and appliances. As of October 2012, the governments participating in SEAD are: Australia, Brazil, Canada, the European Commission, France, Germany, India, Japan, Korea, Mexico, Russia, South Africa, Sweden, the United Arab Emirates, the United Kingdom, and the United States. More information on SEAD is available from its website at <http://www.superefficient.org/>.

Motivation for this Study

Ceiling fans make up a significant amount of residential electricity consumption in many countries around the world. For example, previous research shows that ceiling fans accounted for about 6% of residential primary energy use in India in 2000, and this figure is expected to grow to 9% in 2020 (de la Rue du Can et al. 2009). Fan use in the commercial sector is also likely to be significant, a recent study on appliance load in residential and commercial sectors in the western state of Gujarat in India found that ceiling fans accounted for 5.7% of the load from commercial establishments (Garg 2010). Fans are also well known to be a cost-effective option for reducing air conditioner electricity demand; air conditioners account for about 16% of residential electricity consumption in the U.S. (U.S. DOE & U.S. EPA 2010). Thus, the energy efficiency of ceiling fans is an important area to address in reducing overall energy consumption in many countries.

However, the economic and engineering literature and data on ceiling fan energy consumption and efficiency improvement options are sparse. This study analyzes the cost-effectiveness of several efficiency improvement options in ceiling fans and estimates the global potential for energy and carbon dioxide (CO₂) emissions savings. We utilize the Bottom-Up Energy Analysis System (BUENAS) to make these global potential estimates. This paper also offers some insights into design of policies to support ceiling fan energy efficiency improvement.

Objective and Scope

The objective of this analysis is to identify potential ceiling fan efficiency improvements and their incremental costs to assess the cost effectiveness of these options and to provide approximate global and country-specific estimates of the total energy savings potential of these improvements. The overarching goal is to provide relevant and appropriate information to support the design of policies and programs that will accelerate the market penetration of efficient ceiling fans.

Although ceiling fan systems are made up of multiple components that affect energy consumption; this report focuses on two of the most important components from energy consumption perspective that could be improved: *motors and blades* (see Figure 1). Figure 2 shows data on energy efficiency of U.S. ENERGY STAR qualified ceiling fans. The far left data points represent fans that have brushless direct current (BLDC) motors which are almost twice as efficient as induction motors typically used in ceiling fans and also have more efficient blades. As a result these ceiling fans are between *two to four fold* more efficient as the US Energy Star requirement. These results are indicative of the large potential for ceiling fan energy-efficiency improvements using commercially available technology.

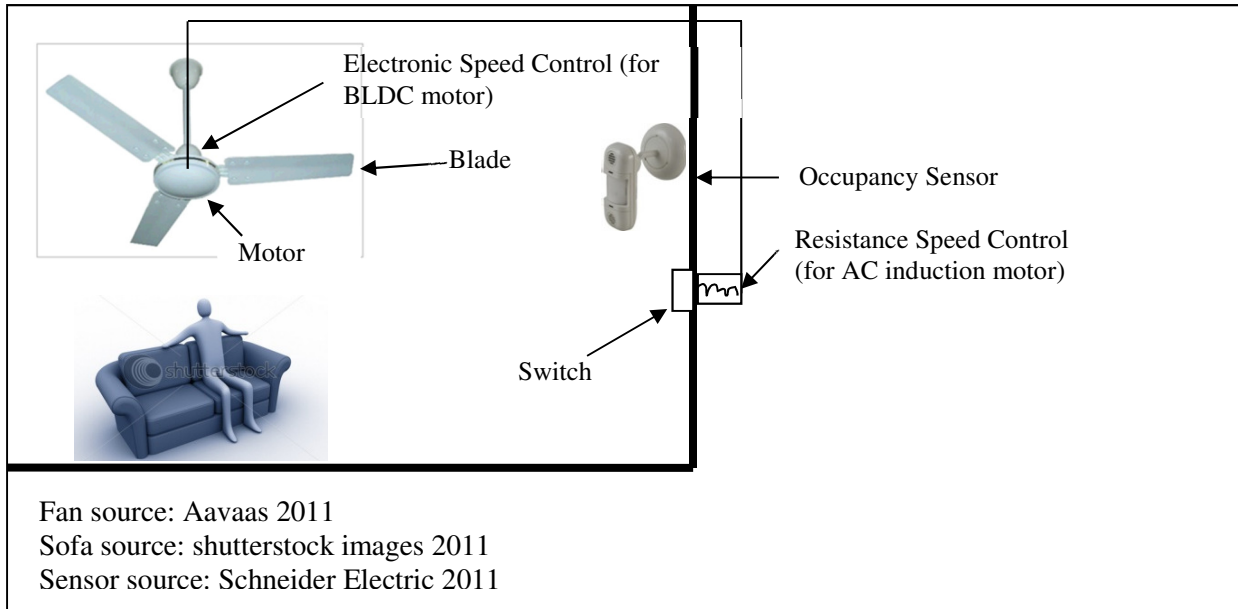
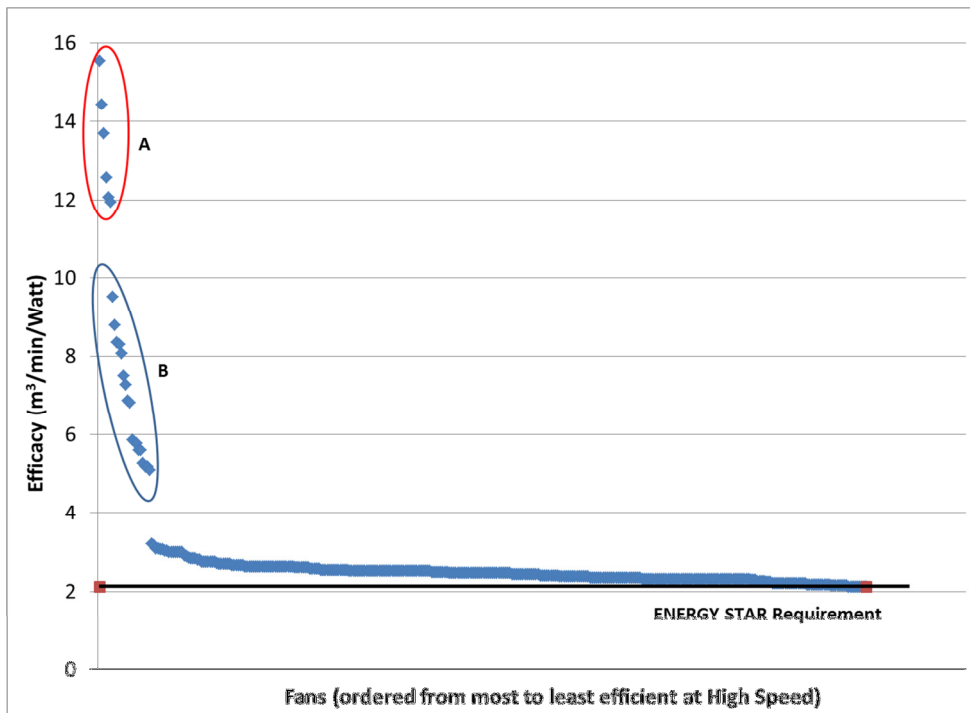

Figure 1 Ceiling Fan Components



Source: ENERGY STAR 2012a, 2012b

Figure 2 Efficacy of ENERGY STAR ceiling fans (combination of fan-only products and fan with light kit) at high speed.³

³ Group A are confirmed to employ BLDC motors, while all but one of of group B employs DC motors.

Data Sources and Analysis Method

The literature and available data on ceiling fan energy consumption are sparse. Our team obtained the data for this report from a review of the literature, including technical reports; U.S. ENERGY STAR databases; participation in international conferences; and interviews with experts in the field.

We begin by clarifying ceiling fan performance measures, with attention to the fluid mechanics of turbomachinery. We derive relationships among: ceiling fan power consumption, rotation speed, downward air velocity, volumetric airflow, and efficacy (measured in airflow per unit power consumed). This allows us to understand the engineering basis of current ceiling fan standards in various countries.

We then consider efficiency improvement options focusing on the introduction of efficient fan blades, efficient alternating current (AC) induction motors, and the substitution of brushless direct current (BLDC) motors for AC induction motors. We show that the most efficient fans on the market are already using some of these technologies, such as BLDC motors and efficient blades. We estimate the cost of implementing these efficiency improvement options and the corresponding gains in efficiency from a review of the literature and interviews with experts in the field and estimate their cost effectiveness.

We utilize our estimates for the efficiency improvement potential for a typical ceiling fan in the Bottom-Up Energy Analysis System⁴ (BUENAS) to assess the global potential energy consumption and CO₂ emissions benefits of increased ceiling fan efficiency. Our analysis compares future ceiling fan energy consumption for two scenarios: a base or business-as-usual (BAU) case, which assumes current usage and efficiency trends, and an efficiency scenario, which considered adoption of cost effective efficiency measures in new ceiling fans sold. The electricity consumption reduction seen in this efficiency scenario represent an approximate estimate of the total cost effective techno-economic saving potential, a part of which can be captured by promoting policies and programs to accelerate the adoption of efficient fans.

Analysis Results

Results for individual ceiling fans are used to inform results of potential global energy savings from fan efficiency improvements.

A. Benefits for Individual Ceiling Fans

We estimate the cost of conserved electricity (CCE) for various efficiency improvement options to assess their cost effectiveness; improvements for which CCE is lower than the cost of

⁴ <http://www.superefficient.org/en/Products/BUENAS.aspx>

electricity are cost effective.⁵ CCE is estimated by dividing the electricity savings due to an efficiency improvement option by the annualized incremental cost of that efficiency improvement option. Table 1 shows estimates of the cost of conserved electricity (CCE) and corresponding annual energy savings from using the various energy efficiency improvement options in fans in India. These results show the significant potential for cost effective savings because CCE for these options is less than 3 cents/kWh whereas the cost of electricity is typically greater than 7 cents/kWh. We note that although Table 1 is focused on India, these improvements are feasible currently, so the technology also has potential for being utilized internationally. Cost effectiveness analysis of efficiency improvement options in other economies are presented in Appendix D. Since our analysis is primarily based on data on costs of efficiency improvements in India and US, the cost effectiveness analysis is more robust for these countries. Given the globally traded nature, maturity and high contribution of materials costs to the total costs of the efficiency technologies considered, we argue that cost estimates based on the data in India and US are likely to be a reasonable approximation of the costs in other regions. The cost effectiveness analysis for other regions takes into account region specific estimates of usage and discount rates.

Table 1 Incremental manufacturing costs, annual energy savings and CCE for various efficiency improvement options in ceiling fans in India⁶

Efficiency Improvement Option	% reduction from baseline power	Average incremental manufacturing cost(\$)	Annual energy saved per fan (kWh)	CCE (\$/kWh)
Improved AC Induction Motor (A)	36%	\$1.5	80	\$0.005
BLDC Motor (B)	50%	\$10.5	112	\$0.027
Efficient Blades (C)	15%	\$3.5	33	\$0.031
A+C	45%	\$5.0	101	\$0.014
B+C	57%	\$14.0	129	\$0.032

B. Global Potential Energy Savings

As seen in Table 1, achieving 50% reduction in power consumption using BLDC motors is cost effective. A combination of BLDC motors and efficient blades can reduce the consumption further. As a conservative estimate, based on the discussion in section 2.2.3, the global energy

⁵ Cost of electricity(CCE) for consumers is the electricity tariff; hence if CCE is lower than the tariff, then the corresponding efficiency improvement options are cost effective from a consumer perspective.

⁶ Efficiency improvement options from single components are presented first followed by efficiency improvement options from combining two options. The options are subsequently ordered by increasing cost of conserved energy. Also option C, efficient blades can be used with both BLDC and AC motors. While BLDC motors and AC motors are widely available, efficient blades may be proprietary designs, and also carry associated aesthetic tradeoffs.

savings analysis using BUENAS assumes that ceiling fan energy consumption can be reduced by 50%. The results of our analysis, depicted in Figure 3, indicate that a phase-in from 2012 to 2016 of efficient ceiling fans with equivalent improvements could significantly reduce global residential energy consumption. Residential energy consumption could be reduced by approximately 70 TWh/year by 2020 versus the business as usual (BAU) scenario.

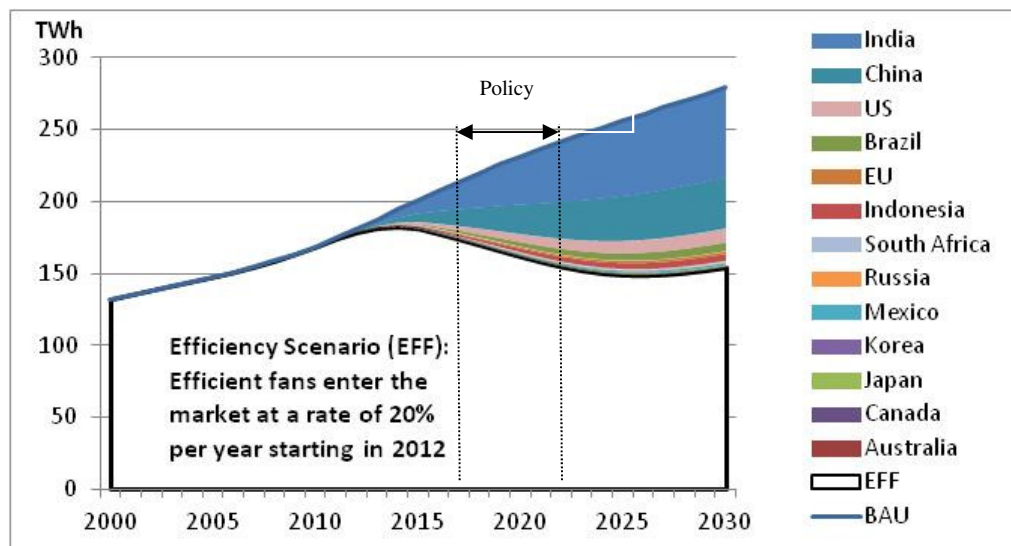

Figure 3 Potential electricity savings resulting from introduction of efficient fans, 2000-2030

C. Insights for Market Transformation Programs

This paper shows that there are several cost-effective options to improve ceiling-fan efficiency that could reduce fan energy consumption by more than 50%. Several barriers, including high first cost and lack of information (e.g., lack of labels that recognize highly efficient performance, lack of technical capacity), have been identified as contributing to the limited adoption of highly efficient fans (Singh et al. 2010). Out of the several types of policies typically used to accelerate adoption of efficient products (e.g., awards, incentives, and standards and labeling programs), standards and labeling programs are the most commonly used to accelerate the market penetration of efficient fans.

The standards and labels levels for Bureau of Energy Efficiency (BEE)’s star rating program in India are presented in Figure 4. These efficacy levels are tested under different conditions (notably airflow requirements/speeds) than standards and labels in the US, Europe and China so they cannot be directly compared against each other without accounting for this fact.⁷ However, the improvements in efficacy discussed in this report are applicable across the range of

⁷ See Appendix C for a discussion of the effect of fan speed on efficacy. Increasing airflow from 5000 CFM (the US high speed) to 7415 CFM (i.e. 210 m³/min, the minimum airflow for star rated fans in India), i.e. A 48% increase will yield a decrease in efficacy of at most 35%.

commonly encountered airflows, i.e. these improvements will offer significant energy savings of a similar order of magnitude regardless of airflow, and test procedure alignment. For comparison, the US ENERGY STAR label has an efficacy requirement of 4.2 (m³/min/W) at low speeds and 2.1 (m³/min/W) at -high speeds while the lowest standard for efficacy in China varies by fan size from 3.47 (m³/min/W) for 1800 mm fans to 2.75 (m³/min/W) for 900 mm fans (U.S. DOE & U.S. EPA, 2010, and AQSIQ, 2010).

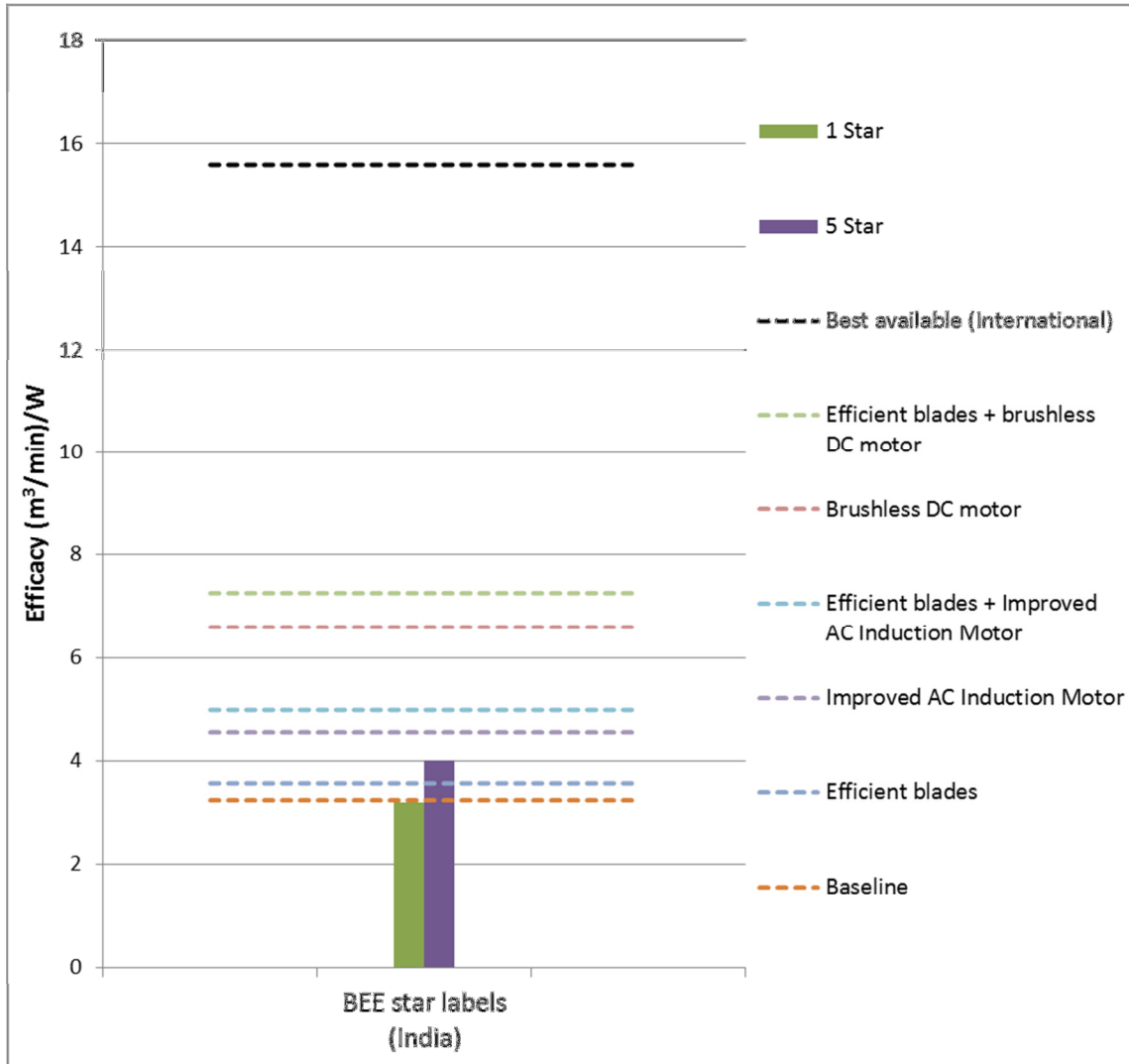

Figure 4 BEE (India) star labels compared to estimates of potential ceiling fan efficacy⁸

Thus as is evident from Figure 4, the highest efficacy level recognized by labels in several countries is significantly lower than what can be achieved by adopting cost effective efficiency

⁸ Note: The baseline efficacy value is based on the average values reported as 'National Player's Models' presented in (Garg & Jose 2009). Incremental improvements correspond to those presented in section 2.2. The efficacy level of the best available fan corresponds to the fan with the highest efficacy in Figure 4.

options. Hence current efficacy label levels need to be revised significantly to encourage deeper penetration of efficient ceiling fans at the top of the market with efficacies achievable using BLDC motors and efficient blades that are already on the market in the US, and that are cost-effective.

The low penetration levels of efficient ceiling fans in both India and the US even with labeling programs in place⁹ seems to indicate the presence of barriers to efficiency in addition to information, such as first cost, (e.g. as discussed in Reddy, 1991) that may not be able to be addressed fully within a standards and labeling framework. In emerging economies, consumers are highly sensitive to high first costs (Singh et al. 2010). However, despite the large saving potential, financial incentive programs to promote the adoption of highly efficient fans by removing this first cost barrier are not common.

One notable example under development is the Super-Efficient Equipment Program (SEEP) in India where financial incentives will be provided to fan manufacturers to produce and sell highly efficient fans that consume less than half of the energy consumed by fans typically sold on the Indian market (Singh et al. 2010). Even if the entire incremental cost of the highly efficient fans is covered by the financial incentives, the cost of the conserved electricity for efficiency improvements over 50% is just Rs. 0.7 per kWh (\$0.014/kWh) which is about one sixth of the cost of supplying electricity in India (J. Sathaye & Gupta 2010). SEEP or a similar upstream incentive program for ceiling fans would be cost-effective even assuming higher costs and lower hours of use as discussed in section 2.3.

It is quite likely that a financial incentive program accelerating the penetration of highly efficient fans has a large cost effective saving potential in several other countries and should be considered as one of the key options for reducing electricity demand and emissions.

⁹ BEE's voluntary star rating program for fans only covered 2% of the Indian market, while only 18% of the fans (without a light kit) on the US ceiling fan market were compliant with ENERGY STAR (PWC, 2012, and EPA 2011) indicating significant room for efficiency improvement.

1. Introduction

This report presents the results of an analysis, commissioned by the U.S. Department of Energy, of ceiling fan efficiency. This analysis was prepared in support of the Super-efficient Equipment and Appliance Deployment (SEAD) initiative.¹ SEAD aims to transform the global market by increasing the penetration of highly efficient equipment and appliances. The International Energy Studies group at Lawrence Berkeley National Laboratory performed the analysis. The objective of this analysis is to provide the background technical information necessary to improve the efficiency of ceiling fans and to provide a foundation for the voluntary activities of SEAD participating countries.

SEAD partners work together in voluntary activities to: (1) “raise the efficiency ceiling” by pulling super-efficient appliances and equipment into the market through cooperation on measures like incentives, procurement, and awards; (2) “raise the efficiency floor” by working together to bolster national or regional minimum efficiency standards and labels; and (3) “strengthen the efficiency foundations” of programs by coordinating cross-cutting technical analysis to support these activities.

Energy-efficiency programs for appliances and equipment have successfully reduced electricity consumption in many locations around the world (Geller et al. 2006). In addition, energy efficiency is an approach by which development pathways can be directed toward lower greenhouse gas (GHG) emissions, increased economic benefits (J.Sathaye et al, 2009), and job creation (Wei et al. 2010). Significant opportunities exist to improve the efficiency of major energy-consuming appliances and equipment (McNeil et al. 2008; Phadke 2010).

Ceiling fans contribute significantly to residential electricity consumption in warm climates and especially in developing countries. For example, in India, ceiling fans accounted for about 6% of residential primary energy use in 2000. This figure is expected to grow to 9% in 2020 (de la Rue du Can et al. 2009), an increase that is equivalent to the output of 15 mid-sized power plants.² In addition, ceiling fan ownership rates have been shown to significantly increase in low-income Indian households as income levels increase (de la Rue du Can et al. 2009). However, in India as

¹ An initiative of the Clean Energy Ministerial (CEM) and a task within the International Partnership for Energy Efficiency Cooperation (IPEEC), SEAD seeks to engage governments and the private sector to transform the global market for energy-efficient equipment and appliances. As of October 2012, the governments participating in SEAD are: Australia, Brazil, Canada, the European Commission, France, Germany, India, Japan, Korea, Mexico, Russia, South Africa, Sweden, the United Arab Emirates, the United Kingdom, and the United States. More information on SEAD is available from its website at <http://www.superefficient.org/>.

² For this estimate we assume an increase in BAU power consumption of ~20TWh, as outlined in the global analysis (Section 3 of this report). We also conservatively estimate that one-tenth of ceiling fans are used during the peak hour and that a mid-sized power plant has a 500-megawatt capacity and runs at 70% efficiency, as described by (Kooimey et al. 2010). However, currently installed power plants in India have a much lower average efficiency (de la Rue du Can et al. 2009).

in most developing countries, much of the efficiency literature and efficiency programs to date have focused on lighting improvements, primarily to encourage a shift from incandescent to compact fluorescent bulbs.³ The only notable study to estimate the potential for electricity savings and GHG emissions mitigation through improvements in the efficiency of ceiling fans is Letschert and McNeil (2008). Although ceiling fan standards and labeling programs are specified for every major economy in the world (Waide et al. 2011), these programs only discourage highly inefficient fans from the market. As a result, a large savings potential remains untapped. Information on commercially available highly efficient fans suggests that, in most instances, fan electricity consumption can be reduced by more than 50% compared to what is stipulated by standards and labeling programs. For example, the Emerson Midway Eco fan is advertised as operating at high speed with an efficacy of $10 \frac{m^3}{min}/W$ (Emerson Climate Technologies 2010), compared to the Bureau of Indian Standards (BIS) minimum standard of $4 \frac{m^3}{min}/W$ for a fan with 1.2-meter (m) diameter (Bureau of Indian Standards 2007), which is the most stringent standard for ceiling fans in the world. Both values are significantly higher than the U.S. ENERGY STAR voluntary criterion of $2.1 \frac{m^3}{min}/W$ for a ceiling fan operating at high speed.

In developed countries and countries with milder climates, a smaller fraction of electricity consumption is attributable to ceiling fans than in developing countries and those with warmer climates. Nevertheless, ceiling fans account for as much as 5% of residential electricity use in the U.S., although this varies greatly by region (Calwell & Horowitz 2001). Even in areas where ceiling fans do not constitute a significant fraction of electricity demand, they can reduce energy consumption by reducing other cooling or heating demands. Fans are well known to be a cost-effective option for reducing the electricity demand of air conditioners (R.-L. Hwang et al. 2009; Arens et al. 2009), and air conditioners are responsible for about 16% of residential electricity consumption in the U.S. Fans also make heating sources more effective when operated in reverse mode (U.S. DOE & U.S. EPA 2010). In addition, ceiling fans are typically considered essential features of passive cooling designs aimed at achieving energy efficient thermal comfort (S. Ho et al. 2009; Santamouris et al. 2007).

The above facts demonstrate that increasing the energy efficiency of ceiling fans is important for reducing energy consumption associated with cooling in many countries around the world. Despite this fact, there is a little information and documentation available on ceiling fans and energy consumption. Thus, there is need for systematic technical and economic analysis of efficiency improvement options for ceiling fans, taking into account the latest engineering developments, such as we undertake in this study.

³ Lighting programs can be identified in several countries around the world (de M. Jannuzzi & dos Santos 1996; Dutt & Mills 1994; Obeng & Evers 2010; Sauer et al. 2001; Shensheng et al. 1996).

This study assesses the potential for fan efficiency improvement options to save energy, resulting in corresponding environmental and economic benefits in various countries. We analyze the cost-effectiveness of fan efficiency improvements and estimate the global potential for energy and CO₂ emissions savings. We utilize BUENAS to make these estimates (McNeil et al. 2008). Section 2 of this report presents a technological and economic analysis of fan efficiency improvement options and Section 3 presents global energy savings estimates. Section 4 describes ancillary benefits, particularly for sustainable development. Section 5 discusses uncertainties and future work, and concludes the paper.

2. Technological-economic assessment of efficiency improvement options in ceiling fans

This section discusses the potential for improving ceiling fan efficiency from an engineering standpoint.

2.1. Measuring ceiling fan performance

The purpose of this discussion is to clarify terminology related to fan performance, describe how shifting fan design variables can affect performance, and relate these issues to the state-of-practice in policy design. Fluid mechanics concepts applicable to fan operation are presented in Appendix A.

2.1.1. Efficiency and efficacy

Ceiling fan energy performance is typically measured in airflow per unit power consumed, in units of $\frac{m^3}{min}/W$. The thermal comfort effects of fans are dependent on: a) downward air speed (s), measured in units of m/min ; b) the area measured in m^2 , of the annulus covered by the sweep. Airflow (q) measured in m^3/min can be described as a function of air speed (s), as shown in Eq. 1, where r is the distance from the center of the fan, l is the length of the maximum coverage radius, and s is a function of r .

$$q = 2\pi \int_0^l s(r) dr \quad \text{Eq. 1}$$

The reason that s is described as a function of r is that air speed varies along the radius of the fan (Bassiouny & Korah 2011); however we note that Eq. 1 inherently assumes that airspeed is constant along each circumference associated with each given value of r on the interval $[0, l]$. Eq. 1 can be simplified to Eq. 2 in the hypothetical situation that airspeed is constant along the radius of the fan, and in turn s is uniform over the coverage area (a).

$$q = a \times s = \pi r^2 \times s \quad \text{Eq. 2}$$

The variable q can be divided by the power demand p to derive the performance measure in units of $\frac{m^3}{min}/W$, which represents the ratio of air delivery to power input. Thermal comfort will be further considered in section 4 and Appendix B. The term “efficiency” is commonly used in an overall sense in the energy-efficiency literature, as well as in engineering discussions to represent the ratio of mechanical output to electrical input power. In this paper, we follow the example of earlier studies (e.g., Chakraborty et al. 2004) and use the term “efficacy” to refer to fan performance when it is specifically discussed in units of $\frac{m^3}{min}/W$, and the term “efficiency” as a general performance descriptor and when discussing motors. Note: In Europe and India the term “Service Value” is used to refer to efficacy.

2.1.2. Treatment of fan performance in standards and labeling programs

Standards and labeling programs for ceiling fans are typically designed to ensure a specified level of efficacy. Specifications include sub-categories that are classified by characteristics such as fan *size, operating speed or airflow*. Fans have higher efficacy at lower speeds, as described in Appendix C. Therefore standards and labeling programs categorize fans by operating speed. Fan efficacy can also be increased through increasing blade length, as described in Appendix A, because power consumption is proportional to the inverse of the fourth power of blade length, at constant airflow. Accordingly, some programs categorize fan standards and labels by fan size or sweep.

Table 2 summarizes fan standards and labeling frameworks in various countries. In the U.S., the ENERGY STAR program specifies minimum ceiling fan efficacy levels for three different airflow levels (U.S. DOE & U.S. EPA 2010). See section 5.1 and Appendix C for a discussion of the importance of including fan speed as a consideration in a ceiling fan efficiency improvement program. Similarly, the Indian standard IS-374 defines minimum efficacy levels for five different ceiling fan size categories. In addition, the Indian Bureau of Energy Efficiency (BEE) maintains a star rating system based on fan efficacy (Singh et al. 2010); however, the Indian star rating system is applicable to only one size of fan (1200 mm) and does not vary by fan speed. The draft European Eco-design (Riviere 2008) and Chinese efficacy standards (General Administration of Quality Supervision Inspection and Quarantine (AQSIQ) of the People’s Republic of China 2010) also vary by fan size. In addition, the Chinese standard functions as both minimum energy performance standard (MEPS), and a rating system.

Table 2 Summary of characteristics used in various standards and labeling programs

Country	Agency	Standard/Label	Mandatory/Voluntary	Speed	Size category	Rating type
India	BIS	Standard	Voluntary		✓	Specifies minimum efficacy for various fan sizes
India	BEE	Label	Voluntary		only 1200 mm	Assigns star ratings to fans meeting minimum efficacy requirements
China	NDRC, AQSIQ	Standard	Mandatory		✓	Assigns ratings based on efficacy, to fans classified by size
U.S.	EPA	Label	Voluntary	✓		Specifies minimum efficacy for fans classified by operating speed
Europe	Ecodesign Forum	Standard	Mandatory		✓	Specifies a minimum efficacy for various fan sizes

Note: A check indicates that the program listed in the row uses the classification characteristic listed in the corresponding column.

2.2. Efficiency improvement options for ceiling fan systems

Ceiling fan systems are made up of several components that affect how efficiently thermal comfort is delivered to users. In this section we describe these components generally and then narrow the discussion to a detailed description of specific improvement options for fan motors and blades and the corresponding improvements in fan efficiency. These estimates of efficiency improvement are then used in the economic analysis in Section 2.3 and in the global assessment of energy savings in Section 3.

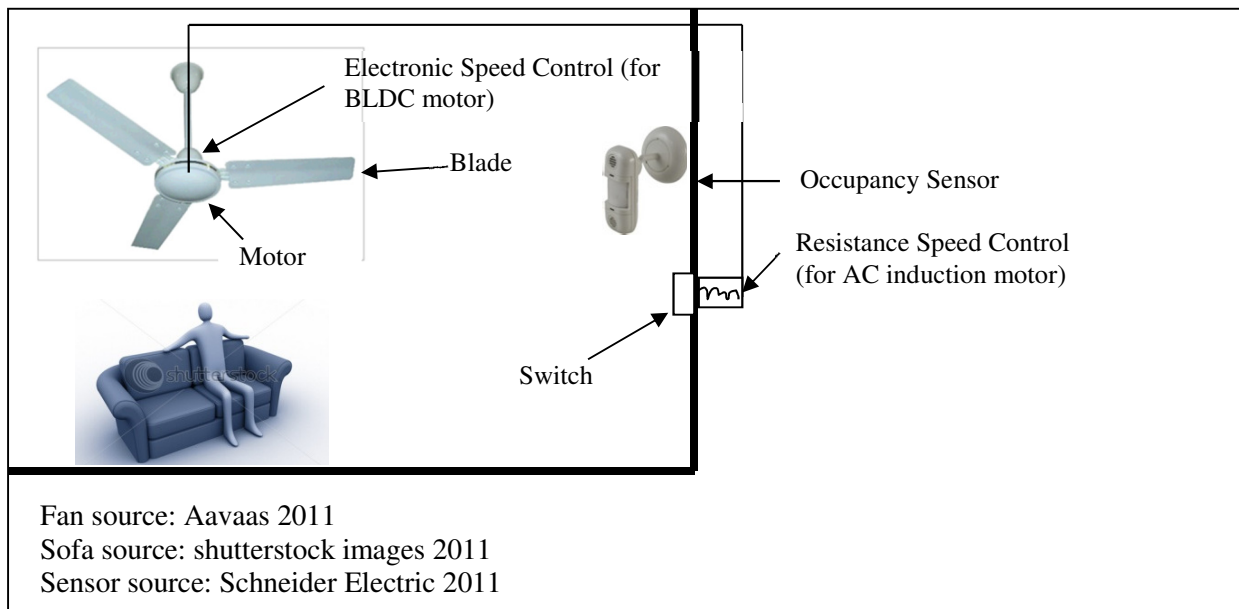

Figure 5 Ceiling Fan System Components

Figure 5 shows that the ceiling fan system consists of multiple components that determine the fan's overall energy consumption. The switch is the human interface component. It can be a wireless remote control, a device attached directly to the fan, or a wall-mounted component, as depicted in Figure 5. Speed control is typically accomplished through resistance switching or electronic control. A resistance speed control for an AC induction motor is inherently inefficient because energy is lost to heat in the resistors. Such mechanisms are common in developing countries. An electronic speed control using transistors for an AC induction motor is more efficient. Electronic commutation, which is used in a BLDC motor⁴, is also relatively efficient because an electronic controller provides AC current to a synchronously rotating BLDC motor. Figure 5 also reminds us of the importance of ensuring that occupants are present and located

⁴ BLDC motors are sometimes also referred to as electronically commutated (EC) motors or permanent magnet DC (PMDC) motors.

within the coverage area of a fan so that they receive the thermal comfort benefits. Room occupancy is a significant concern for energy consumption because much energy is lost when fans remain on after users leave a room. Occupancy sensors can be utilized to alleviate this problem (Parker et al. 1999).

Although remotes, speed controls, and room occupancy sensors are important considerations for fan energy consumption, we do not focus in this paper on these aspects of the ceiling fan system, for several reasons. Stand-by power consumption is already a widely known concern, and efforts are being made to mitigate this problem (European Commission 2010). Instead of focusing on speed controls, we focus on the introduction of BLDC motors that utilize electronic controls, as replacements for AC induction motors. Occupancy sensing is beyond the scope of this paper because it requires a detailed behavioral study to estimate the associated benefits, with much associated uncertainty. Therefore, in this paper we focus on engineering improvements that are easily quantifiable, i.e., engineering changes to fan motors and blades that can significantly improve ceiling fan efficiency.

2.2.1. Fan motors

Historically, ceiling fans, like many household appliances, have utilized AC induction motors because these motors are durable, easy to construct, and relatively inexpensive to manufacture. Specifically, low-power applications such as ceiling fans have typically used split-capacitor and shaded-pole motors. Permanent split-capacitor motors are prevalent in ceiling fans manufactured in India, and shaded-pole motors are prevalent in ceiling fans manufactured in the U.S. and Europe (Pednekar 2010). However, these fan motors are relatively inefficient because of the slip⁵ associated with single-phase induction motors, as well as other losses.

BLDC motors have become increasingly common in appliances in recent decades because of developments in electronic commutation and the availability of high-performing magnetic materials at reasonable cost (Desroches & Garbesi 2011). Such motors are more efficient than brushed DC motors because they do not have the friction losses associated with mechanical commutation; these losses result from the friction between the brush and slip rings in brushed DC motors.

AC induction motors are inefficient because their rotors do not rotate synchronously with the magnetic field that induces rotor motion; this results in slip and therefore inefficiency. Utilizing a BLDC motor alleviates these issues because the rotor moves synchronously with the rotating AC magnetic field produced by electronic commutation. For instance, a 75-W BLDC motor has been estimated to have an efficiency of up to about 90% whereas the average new 75-W AC induction

⁵ The slip is the difference between the speed of the rotor and the magnetic field in an AC induction motor.

motor has an efficiency of around 75% (Desroches & Garbesi 2011). Table 3 shows these efficiencies along with those of other 75-W motors.

Table 3 Efficiency data for various 75-W motor types in the U.S.

Motor type	Efficiency
NovaTorque ⁶	90%
Practical Limits BLDC ⁶	87%
Practical Limits AC Induction	84%
Average New Production	75%
Average Installed Base	60%

Source: Desroches & Garbesi 2011

In addition to the empirical data available through ENERGY STAR, multiple engineering studies have estimated the potential for reducing energy consumption through the use of BLDC motors. One experimental study from Taiwan shows that the energy consumption of a ceiling fan with a BLDC motor is about 50% that of a fan with a split-phase induction motor, for a given rotation speed (Liu et al. 2009). Another experimental study from Australia shows that use of a BLDC motor decreases ceiling fan energy consumption by a factor of three at low speeds and a factor of two at high speeds (Schmidt & Patterson 2001) compared to a fan with a split-phase permanent capacitor induction motor. Industry experts also indicate that using a BLDC motor can reduce energy consumption, by an estimated 60% in the U.S. (Parker 2010) and up to a power consumption level of 30-35W (i.e.50%) in India (Pednekar 2010, PWC 2012) compared to a fan with an induction motor operating at the same speed.

In addition to the potentially far-reaching energy efficiency improvements that could be achieved with BLDC motors, some fans in India incorporate a combination of elements that affect AC induction motor efficiency so that these fans consume significantly less energy than the norm (Pednekar 2010, PWC 2012). Although fans with these improvements have been available for several decades, they are not the norm because they have higher manufacturing and materials costs. Thus there is an incentive for manufacturers to keep costs low by not employing these improvements. At high speeds, these fans can reduce power consumption from 70-75 W to about 45-50 W. The elements that (Pednekar 2010) cites as influencing AC induction motor efficiency in these fans are:

- Increased amount of “active” material, such as lamination steel and copper
- Reduced air gap between stator and rotor
- Use of standard-grade aluminum for a die-cast rotor

⁶ The company Novatorque has incorporated technical improvements to push efficiency further beyond the so-called “practical limits” of a BLDC motor.

Increasing the amount of “active” material, such as lamination steel and copper, increases efficiency by improving the magnetic quality of the rotor and the windings. Reducing the air gap between the stator and the rotor increases efficiency by increasing the magnetic torque induced by windings on the rotor. Using standard-grade aluminum for a die-cast rotor improves efficiency by reducing the weight of the rotor.

2.2.2. Fan blades

Improving fan blade design has been shown to have significant potential for improving fan efficiency. Efficiency improvements have been achieved by multiple approaches, including aerodynamic attachments for conventional blades (Volk 1990); a decrease in the angle of attack through the use of twisted, tapered blades (Bird 2004); and use of twisted, tapered blades with an air foil (Sonne & Parker 1998). We focus on the last of these options because it has the greatest potential for improving energy efficiency and is currently the most widely employed type of efficient blade.

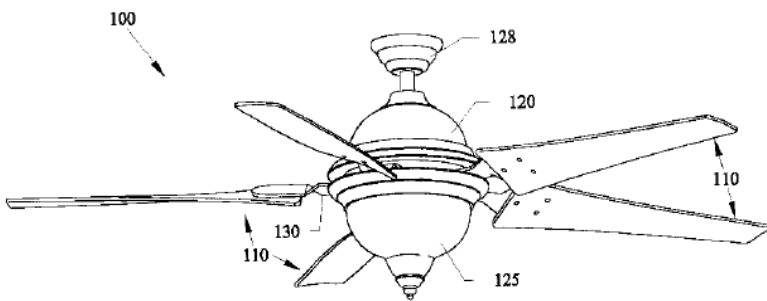
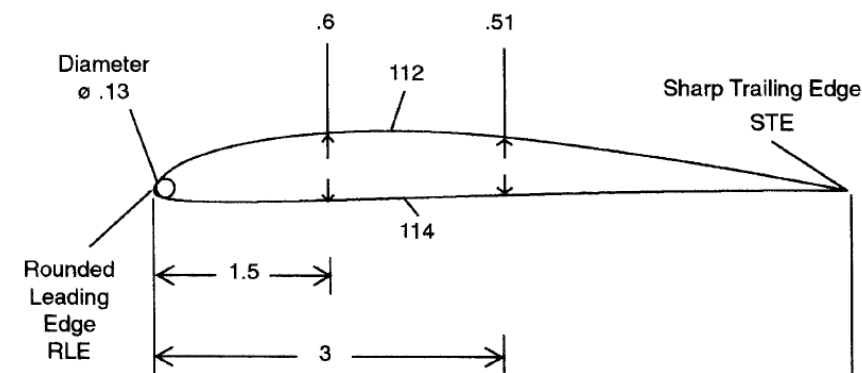

Fig. 6A



Source: Parker et al. 2003

Figure -6 Design drawings from a patent for a ceiling fan with twisted, tapered blades with an airfoil. The first drawing is of the whole fan, and the second is a side view of a blade.⁷

Twisted, tapered blades with an airfoil increase efficiency by reducing energy lost to turbulence and flow separation (Gossamer Wind 2011). Figure 6 depicts this type of blade design. As shown in the figure, the design is tapered in that the cross-section chords become shorter from the inner part of the blade to the outer. The twist and taper create less friction for the outer parts of the blades, which travel a longer circumference than the inner parts. As a result, the blade can move more efficiently. In addition, the cross sections are not flat like traditional blades but have an airfoil shape, so the top side is longer than the bottom side. This contributes to a pressure difference between the two sides of the blades, so air is induced to move to the bottom side.

Although the idea of a blade with a twist, taper, and airfoil is conceptually straightforward, optimal blade design is a detailed process in which multiple objectives must be balanced. These objectives include maximizing air speed, maintaining uniform air speed along the fan radius, and maximizing the airflow coverage to create a larger comfort zone for room occupants. Multiple patents exist for efficient blade designs that address these objectives in different ways. A test of one such patented blade design indicates that the subject invention has an efficacy 86% higher than that of a conventional flat blade at low speeds and 111% higher at high speeds (Parker et al. 2000). These percentages indicate that there is remarkable potential for energy-efficiency improvements from changes in fan blade design because the power demand of a fan is a cubic function of the rotational speed for a constant blade length, as noted in Appendix A, implying that blade design improvements have greater efficacy/power consumption savings impact at higher speeds. A similar airflow can be achieved at lower speeds with much lower power consumption. These blades can also be used to reduce motor size and cost, and the resulting device will still outperform a conventional fan (Parker et al. 2000).

In addition, efficient blade designs have been adapted for aesthetic purposes to look like traditional blades from the bottom side while being aerodynamic on the top side. This blade causes an airflow and in turn an efficacy improvement, for a constant power consumption, of approximately 10% more than the conventional design at high speed and 26% more at low speed (Parker & Hibbs 2010)), which can result in significant energy savings. The blade has been designed to meet a market preference by some consumers for energy-efficient fans with a traditional appearance.

⁷ We note that most fans sold in India have 3 blades as opposed to the 5 pictured here. However, to be consistent with the patent filed by Parker (2003), we have pictured the 5 bladed design from the patent. The blade improvements will be similar for a fan with 3 blades.

These results are in the same range as those given by (Pednekar 2010), who indicates that a new aerodynamic blade design developed using engineering plastics in India would give the same airflow performance at speeds about one third lower. The details about this blade are not precise because it has not yet been introduced to the Indian retail market; however, the efficiency improvements are achieved through an enhanced blade shape and molded fiber-reinforced plastic blades, which are not subject to corrosion like the metal blades that are common in the country.

2.2.3. Fan efficiency improvement opportunities: Empirical evidence from the US market

In this section we present data for ceiling fan efficacies and explain how this empirical information relates to the engineering considerations in Sections 2.2.1 and 2.2.2. Figure 7 and Figure 8 show ENERGY STAR market data for qualifying fans being sold in the U.S. and Canada (U.S. DOE & U.S. EPA 2010). The figures demonstrate the potential importance of BLDC motors and efficient blades, and are consistent with the implications for efficiency that we can draw from the engineering information and studies presented here. The information regarding motor and blade type was obtained from product catalogs and phone calls with representatives of ceiling fan companies producing fans with the highest efficacies. These companies include Monte Carlo, Fanimation, Regency, and Emerson (N. Sathaye 2011). The data in the figures are comparable to the performance of the most efficient fans being introduced in the U.S. and Canadian markets. For instance, the Emerson Midway Eco fan is advertised as having a 75% reduction in energy consumption thanks to the Emerson EcoMotor™ (Emerson Climate Technologies 2010). The best-performing fan in Figure 8 uses this BLDC motor.

The figures show that fans with BLDC motors have far higher efficacies than the current ENERGY STAR high-speed standard requires, and fans with efficient blades also tend to perform on the higher end of the distribution. These data indicate that engineering improvements such as those discussed here can be used for purposes other than increasing efficacy, such as reducing motor size or material quality to reduce manufacturing costs, in the absence of policy intervention to improve efficiency. To the authors' knowledge, there are no fans with BLDC motors in these figures other than those highlighted although this is unconfirmed because we were not able to contact every fan manufacturer.

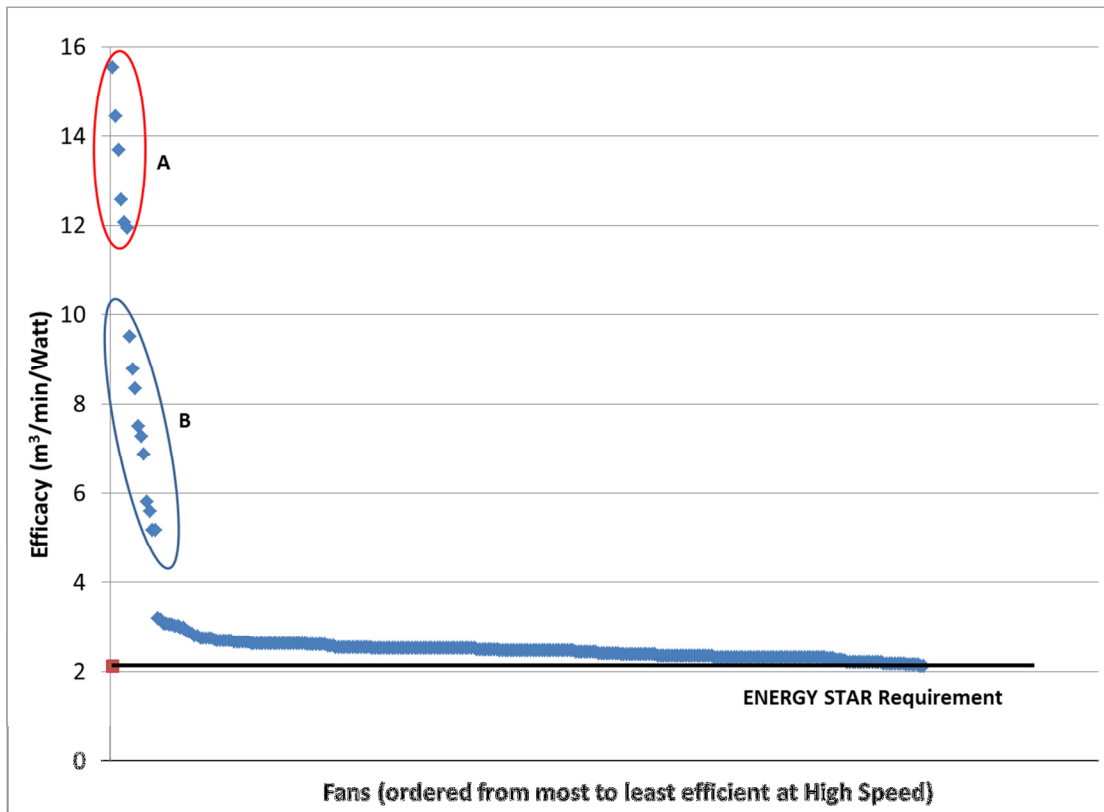

Source: ENERGY STAR 2012a

Figure -7 Efficacies for ENERGY STAR ceiling fans (fan only, without lights) at high speed⁸

⁸ Group A are confirmed to employ BLDC motors, while all but one of of group B employs DC motors. In 2010 and 2011, the market penetration of ENERGY STAR qualified ceiling fans was 18% and 13%, respectively. (ENERGY STAR 2011, ENERGY STAR 2012c)

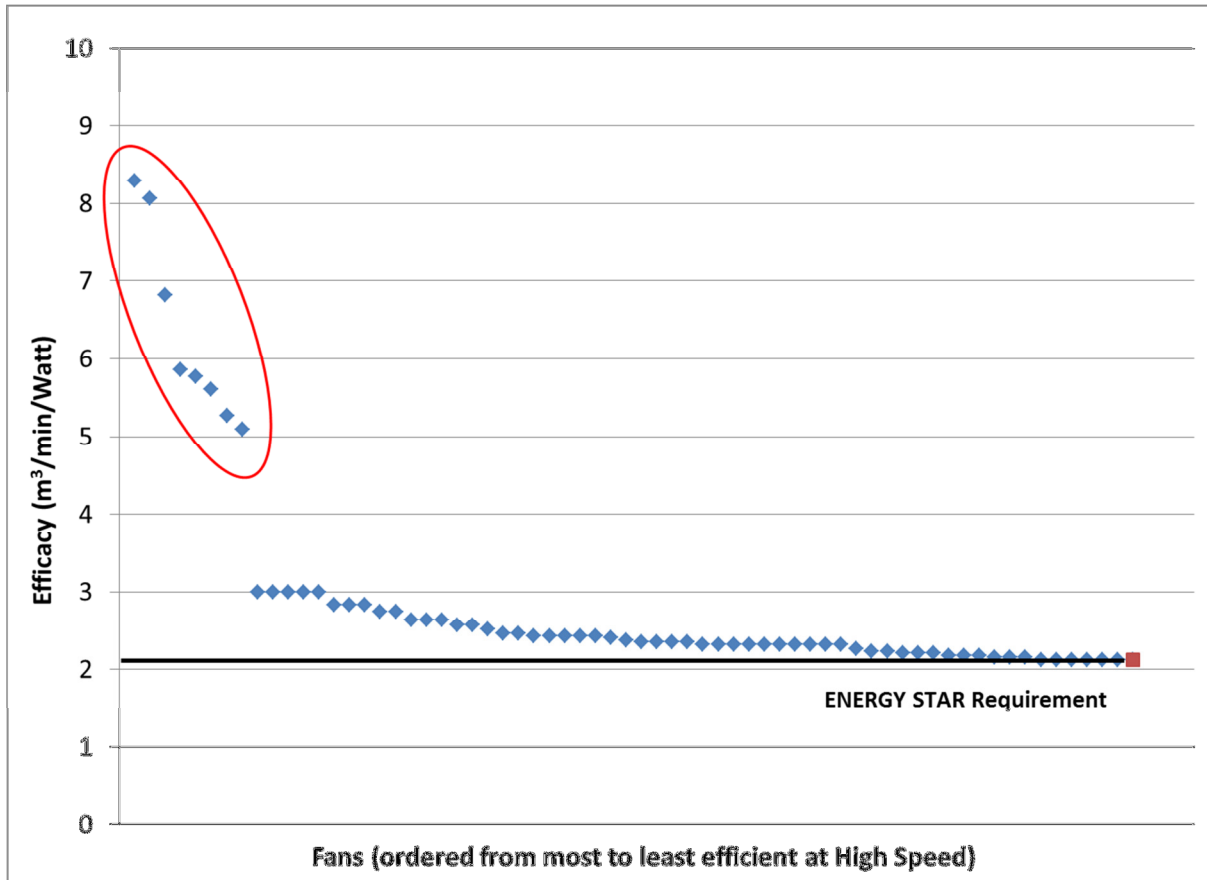

Source: ENERGY STAR 2012b

Figure 8 Efficacies for ENERGY STAR ceiling fans (fan with light kit only)⁹

2.2.3. Summary of Efficiency Improvement Options

We summarize below in Table 4 estimates of fan power consumption from various options based on the discussions in sections 2.2.1 and 2.2.2.

Table 4 Summary of power consumption of efficient fans using various options

Efficiency Improvement Option	Efficient Fan Power Consumption (W)			Average Power Savings (W)	% reduction from baseline power
	Pednekar (2010)	PWC (2012)	Parker & Hibbs (2010)		
Improved AC Induction Motor	45-50	40		25	~36%
BLDC Motor	30-35	35		35	~50%
Efficient Blades			55.5-63.6	10.5	~15%

⁹ All but one of the models in the red ellipse are confirmed to employ DC motors.

We note that actual reported efficacy improvements for the best blade designs are much higher than those summarized in Table 4 above as discussed on Section 2.2.2. For the purposes of this study, we have assumed blade design improvements will lead to relatively lower increases in efficacy of 10-26% (Parker and Hibbs 2010), implying a power consumption of between 55.5-63.6 W, i.e. about 15% improvement in power consumption from a 70 W baseline. These lower efficacy improvement assumptions from fan blades are justified for the following reasons: a) blade design has associated aesthetic and customer satisfaction tradeoffs b) many high efficiency blade designs are proprietary and c) the values assumed provide a conservative estimate. The average efficiency improvement estimates summarized in Table 4 are used in Section 2.3 to estimate the cost effectiveness of these options.

2.3. Technical and Economic analysis of Efficiency Improvement Options

In this section we estimate the costs of improving the efficiency of ceiling fans by using the options described in Section 2.2. We estimate the cost of conserved electricity (CCE) to assess the cost-effectiveness of these efficiency improvements. Because of data constraints, we only cite costs from a few countries while estimating the CCE.

2.3.1. Fan motors

We estimate the incremental cost of improving the efficiency of motors typically used in ceiling fans based on the data collected from industry experts. We consider two types of efficiency improvement options. First, given that BLDC motors are significantly more efficient than induction motors typically used in ceiling fans, we estimate the incremental cost of BLDC motors of the same size and performance specifications over the typical induction motors. Second, we consider the cost of improving the efficiency of the induction motor itself where the efficiency improvements are smaller and less costly compared to those achieved by a shift to a BLDC motor.

Incremental cost of BLDC motors over induction motors

BLDC motors typically have higher cost compared to induction motors primarily because of the extra cost of the controller, whereas the induction motor and BLDC motors have similar materials costs (excluding the BLDC motor controller). This is primarily because the extra cost of permanent magnets in a BLDC motor is compensated by reduction in costs due to less copper and steel (See Chiang 2010 and Desroches & Garbesi 2011 for a detailed discussion). Desroches & Garbesi, find that that the global cost of materials for a 750-W (note that fan motors are typically much smaller, < 75W) induction motor is about US\$43.80, and, for a BLDC motor, the materials cost ranges from US\$24.20 to US\$36.74, as of 2011. This indicates that the *materials* cost of a much smaller BLDC motor, such as would be used in ceiling fans, should also range from a little less than to about equal that of a comparable AC induction motor. Therefore, the incremental cost of the BLDC motor over an induction motor is primarily the cost of the controller. A BLDC motor controller is estimated to have a manufacturing cost between

INR300-700 in India (Pednekar 2010, PWC 2012) and between US\$3.2 to US\$22.5 in the US (Chiang 2010) based on the data from industry experts as shown in Figure 9. We assume the incremental cost of a BLDC motor that can replace a typical ceiling fan induction motor of 75 W to be ~\$10.5 for the purposes of this report.

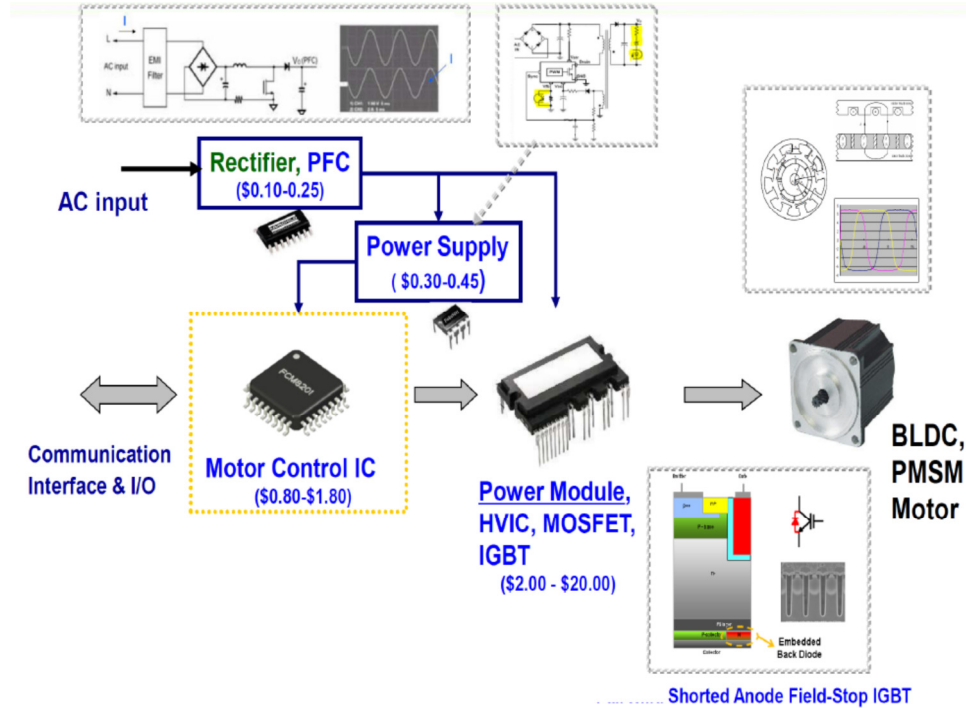

Source: Chiang 2010

Figure 9 Costs of a controller for a BLDC Motor based on components

Cost of improving the efficiency of induction motors

Section 2.2.1 addresses efficiency factors having to do with material quality and optimal motor design of AC induction motors in addition to BLDC motors. These improvements are estimated to increase the manufacturing price of an AC induction fan by about INR 60-100 i.e. (~\$1-1.5) versus the cost of a standard fan in India (Pednekar 2010, PWC 2012).

2.3.2. Fan blades

The cost of manufacturing efficient ceiling fan blades in the U.S. is estimated to be about US\$2.25, versus US\$0.25 per conventional flat blade, as previously mentioned (Parker & Hibbs 2010; Parker et al. 2000). The incremental cost of manufacturing an efficient blade versus a conventional blade in India is about INR 60 for 3 blades i.e. US\$0.36/blade (Pednekar 2010). Although these appear to be significant cost increases for these components, they are not very large (~5%) compared to the total retail price of a ceiling fan. An important point to mention in the case of efficiency improvement through blades is that blade design and manufacture is also driven by aesthetic considerations, rather than just efficiency. This is also reflected in *divergent*

estimates of the costs of manufacturing depending on the design, material, manufacturing, and treatment/finishing processes. The significance of aesthetic considerations in blade manufacture implies that *mandating* more efficient blades through minimum energy performance standards (MEPS) is not likely to be a practical or desirable option. However, given that some fans may be designed to meet energy efficiency policy specifications by using more efficient blades, it is still useful to estimate the costs of efficiency improvement through more efficient blades, particularly for labeling and incentive programs. Table 5 below summarizes the costs of the efficiency improvement options considered, while Table 6 reports these costs in dollar terms along with average numbers which are used as the input for the cost effectiveness calculation.

Table 5. Summary of the reported manufacturing costs of several efficiency improvement options

Efficiency Improvement Option	India		US	
	Pednekar (2010)	PWC (2012)	Chiang (2010)	Parker and Hibbs (2010)
Improved AC Induction Motor	INR 60	INR 100		
BLDC Motor	INR 300	INR 500-700	\$3.2-\$22.5	
Efficient Blades	INR 60/3 blades			\$2/blade

Table 6 Summary of reported manufacturing costs in dollars of efficiency improvement options¹⁰

Efficiency Improvement Option	India		US		Average(\$)
	Pednekar (2010)	PWC (2012)	Chiang (2010)	Parker and Hibbs (2010)	
Improved AC Induction Motor	\$1.09	\$1.82			\$1.5
BLDC Motor	\$5.45	\$10.91	\$3.2-\$22.5		\$10.5
Efficient Blades	\$1.09			\$6.00	\$3.5

2.3.3. Cost of conserved electricity

This section presents the cost of conserved electricity in India for the motor and blade improvements described above, using the efficiency and corresponding cost assumptions presented in Table 4(Section 2.2.3), and Tables 5 and 6 (Section 2.3.2) above. Results for other economies are presented in Appendix D.

¹⁰In converting from a per-blade to a total incremental cost we assume the fan has 3 blades.

Two kinds of CCEs are calculated as follows: a) the cost to the manufacturer of conserved electricity, (CCE_m), which considers the incremental cost of the higher efficiency fan to the manufacturer and b) the cost to the consumer of conserved electricity, (CCE_c), which considers the incremental cost of the higher efficiency model to the consumer i.e. considering retail prices. The former metric (CCE_m) is lower than the latter (CCE_c) as it does not include markups and taxes. Therefore, CCE_m can be used to measure the cost-effectiveness of a market transformation program such as an upstream incentive program, while CCE_c would be used to measure the cost effectiveness of a standards program, or a downstream incentive program.

The CCE is then calculated at various efficiency levels as follows:

$CCE = \text{Annualized incremental cost of efficient fan (\$)} / \text{Annual power saved by efficient fan (kWh)}$

i.e. $CCE_m = \text{Annualized incremental manufacturing cost of efficient fan (\$)} / [(\text{Annual electricity consumed by average fan}) - (\text{Annual electricity consumed by efficient fan})] \text{ (kWh)}$

and $CCE_c = \text{Annualized incremental cost to consumer of efficient fan (\$)} / [(\text{Annual electricity consumed by average fan}) - (\text{Annual power consumed by efficient fan})] \text{ (kWh)}$

Table 7 Cost of conserved electricity for various efficiency improvement options in India¹¹

Efficiency Improvement Option ¹²	Average Power Savings (W)	% reduction from baseline power	Average incremental manufacturing cost(\$)	CCE _m (\$/kWh)	CCE _c (\$/kWh)
Improved AC Induction Motor (A)	25	36%	\$1.5	\$0.003	\$0.005
BLDC Motor (B)	35	50%	\$10.5	\$0.014	\$0.027
Efficient Blades (C)	10	15%	\$3.5	\$0.015	\$0.031
A+C	32	45%	\$5.0	\$0.007	\$0.014
B+C	40	57%	\$14.0	\$0.016	\$0.032

Assumptions: Lifetime=10 years, hours of use per day =8.7 discount rate = 7.6%, multiplier for markup and taxes=2.0

As can be seen in Table 7 improved AC induction motors are the most cost effective single option, followed by BLDC motors. We also note that our cost and efficiency assumptions (and resulting CCE estimates) regarding efficiency improvement using more efficient blades are *conservative* and may very well be lower than those shown here for the following reasons a) we have used cost and efficiency estimates for more efficient blades with a traditional appearance as

¹¹ We have assumed a 100% markup in estimating costs to the consumer in line with PWC 2012. Lifetime and hours of use assumptions are in line with Boegle et al. 2010.

¹² Efficiency improvement options from single components (A, B, C) are presented first followed by efficiency improvement options from combining two options (A+C and B+C). The options are subsequently ordered by increasing cost of conserved energy. Also option C, efficient blades can be used with both BLDC and AC motors. While BLDC motors and AC motors are widely available, efficient blades may be proprietary designs, and also carry associated aesthetic tradeoffs.

discussed earlier (Parker and Hibbs 2010) rather than the most efficient blades, b) the data on blades indicated *divergent* estimates of the costs of manufacturing depending on the design, material, manufacturing, and treatment/finishing processes which varied due to aesthetic considerations. In order to present a fuller picture of cost effectiveness under various scenarios we also present the results of a sensitivity analysis on the CCE in the next section. Since our analysis is primarily based on data on costs of efficiency improvements in India and US, the cost effectiveness analysis is more robust for these countries. Given the globally traded nature, maturity and high contribution of materials costs to the total costs of the efficiency technologies considered, we argue that cost estimates based on the data in India and US are likely to be a reasonable approximation of the costs in other regions. The cost effectiveness analysis for other regions presented in Appendix D takes into account region specific estimates of usage and discount rates.

2.3.4. Sensitivity of Cost-Effectiveness Analysis

To illustrate the cost effectiveness of the various options under varying assumptions on hours of use and cost, we present three scenarios for various hours of use. We varied the costs of efficiency improvement from BLDC motors by calculating the CCE_m using our high incremental cost estimate of \$22.5 in the “high cost” scenario, and our low incremental cost of \$3.2 in the “low cost” scenario. These results are presented in Figure 11, showing the cost of conserved electricity under the base cost (\$10.5), low cost (\$3.2) and high cost (\$22.5) scenarios. These cost estimates are in line with the high and low estimates reported by Chiang 2010. The range of hours of use per day shown (4-12 hours) is also consistent with the ranges reported in Boegle et al 2010 who showed a lower range of 3-5 hours of use/day and a higher range of 10-16 hours of use/day. We also show the estimated impact on cost-effectiveness in moving from an upstream program to a downstream incentive program or a standards program using the CCE_c metric discussed earlier. This is represented as the curve labeled “Downstream” in Figure 10. A typical tariff for India is shown to be approximately 8cents/kWh (~4.5 rupees/kWh).

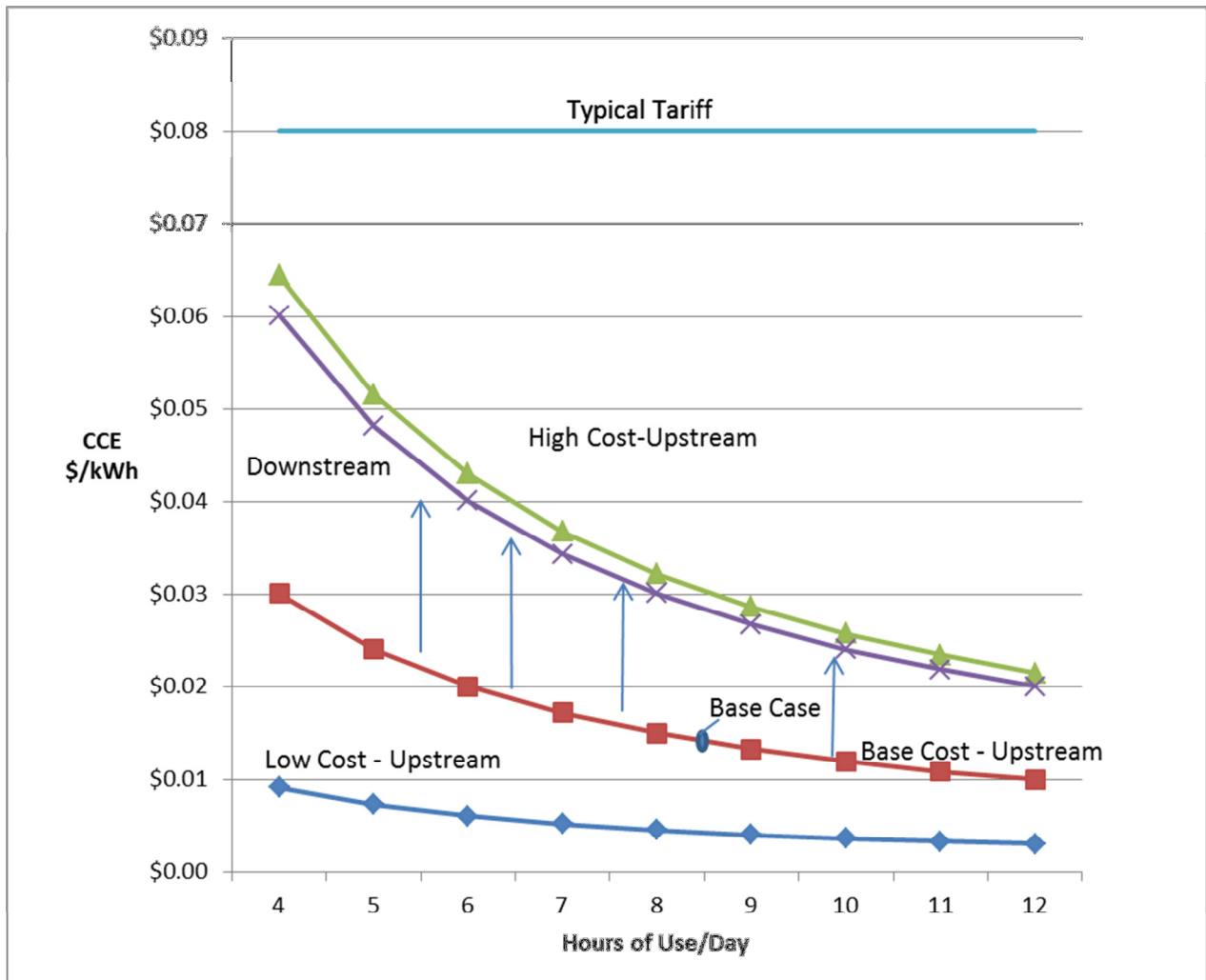

Figure 10 Sensitivity Analysis of Cost Effectiveness of Incentive Programs in India, assuming 50% power savings.

The results shown in Figure 10 show that an upstream incentive program for ceiling fans in India is cost effective even assuming low hours of use and high incremental costs of efficiency improvement for improvements equivalent to the 50% savings in power consumption obtainable using a BLDC motor. Other countries with high ceiling fan usage (i.e. high unit energy consumption from ceiling fans), will also find these efficiency improvements cost-effective, as discussed in Appendix D.

3. Energy Savings Potential

We used the Bottom-Up Energy Analysis System¹³ (BUENAS) to estimate the potential global energy and CO₂ emission savings potential from accelerated implementation of the engineering developments for ceiling fans described in Section 2. A detailed description of the methodology

¹³ <http://www.superefficient.org/en/Products/BUENAS.aspx>

is available in (McNeil et al. 2008) and (McNeil et al. 2012). This version of BUENAS covers 13 major economies, representing 80% of the world’s total energy consumption. Section 3.1 summarizes the model’s methodology, data, and assumptions. Section 3.2 presents the modeled global energy savings and CO₂ emission reductions. Our objective is to provide an approximate estimate for the potential savings from accelerated adoption of efficient fans. More precise estimates of the saving potential in each of the economies covered by the model will require significant further work to provide a more robust empirical basis for the assumptions used in the model. Note that we have more robust data on India, China, and the US compared to other countries and hence the estimates of saving potential for these countries are likely to be more accurate than for the others.

3.1. Data and Methodology

BUENAS is an end-use energy forecasting model designed to provide a detailed assessment of the potential for energy savings and GHG emissions reductions from energy-efficiency standards and labeling programs worldwide (see McNeil et al 2012 for a detailed description of the model). The model is “bottom-up” in that it calculates energy demand based on input data for individual appliance products. BUENAS has three modules. The first calculates the number of appliances per household (diffusion) in a country at a given point in time, primarily based on an empirical relationship observed between appliance ownership and macroeconomic household variables such as household income. The second module estimates energy consumption and efficiency improvements at the appliance level. The third module is a stock turnover module that calculates the sales of appliances in every year based on retirement of old units and increased penetration of appliances in households. This module combines the sales in every year with unit energy consumption (UEC) to estimate the total stock energy consumption. The difference in stock energy consumption between a Business As Usual (BAU) and an efficiency case equals the savings. Energy savings are then converted into CO₂ emissions mitigation according to the power generation mix from each country.

Ceiling fan sales data are useful for estimating appliance diffusion in the first module of BUENAS. However, ceiling fan sales data are not easily obtained because fans are a relatively unstudied product. Therefore, we estimate sales data based on the estimated stock of fans in the countries included in this study other than India, the U.S. and those in Europe. For countries other than India, the U.S., and European nations, we estimate diffusion using the logistic formula in Eq. 3.

Table 8 presents the estimation results, including parameter values, the statistical significance of parameters, and goodness of fit information.

$$Diff_c = \frac{\alpha}{1 + \gamma \times \exp(\beta_{inc}I_c + \beta_{elec}E_c + \beta_{CDD}CDD_c)} \quad \text{Eq. 3}$$

Where:

$Diff_c$ is the average number of fan per household for the country c

α is the saturation level

I_c is the household income given by GDP divided by the number of households in the country (PPP \$2007)

E_c is the electrification rate (%)

CDD_c is the average number of Cooling Degree Days per year (%)

β_{inc} is the diffusion parameter for income

β_{elec} is the diffusion parameter for electrification

β_{CDD} is the diffusion parameter for cooling degree days

Table 8 Diffusion Parameters for Fans

		Parameters:	$\ln(\gamma)$	β_{inc}	β_{elec}	β_{CDD}
$\alpha =$	3	Coefficient:	0.80	9.79×10^{-7}	-1.13	3.41×10^{-4}
Observations =	11	t-statistic:	0.82	0.20	-1.15	2.55
$R^2 =$	0.79					

Estimated sales data for the Indian residential sector are available for 2005, 2008, and 2013 (Boegle et al. 2010). Sales are extrapolated based on Eq. 3 and the parameter estimates in Table 8. For the European Union, the number of fans per household is obtained from household surveys and (Riviere 2008). This number is assumed constant in the forecast. For the U.S., sales data are available from 2003-2004 and 2006-2010 from NPD (NPD, 2012, NPD 2011). We applied the number of households' growth rate to the latest year of data available in order to forecast sales to 2030. For China, detailed ownership data are available, and a model specific to China is applied (Letschert et al. 2009). Table 9 summarizes the results and methods for the first module of BUENAS. In the last column, "Macroeconomic model" refers to the methods described in (McNeil et al. 2008), which include Eq. 3.

Table 9. Stock of fans calculated in BUENAS, by country

Country	Stock in 2010 (Millions)	Stock in 2030 (Millions)	Source/Assumption
Australia	15	20	Macroeconomic model
Brazil	90	139	Macroeconomic model
Canada	25	34	Macroeconomic model
China	717	934	Macroeconomic model
EU	272	319	(Riviere 2008)
India	224	559	Calculated from sales data
Indonesia	43	64	Macroeconomic model
Japan	78	81	Macroeconomic model
Korea	32	42	Macroeconomic model
Mexico	29	35	Macroeconomic model
Russia	100	93	Macroeconomic model
South Africa	13	15	Macroeconomic model
U.S	211	253	<i>Calculated from sales data</i>

The second module of BUENAS uses assumptions of appliance-level energy consumption, based on usage data and technology options. Fan unit energy consumptions (UECs) are developed for a BAU case, which relies on international references to estimate the average consumption of fans in each country. Based on the engineering options discussed in Section 2.2, an efficient scenario is developed, assuming that a 50% improvement versus the baseline UEC (BAU) can be achieved in each country. We assume a 50% improvement value because this is the approximate improvement achievable with the introduction of BLDC motors. Although different values could be used based on the engineering analysis presented in section 2.2 (e.g. different baseline technologies in various countries may lead to higher savings than the 50% assumed here), we do not attempt to extrapolate precise engineering data to the global scale because of the many assumptions that would be required. Instead, we simply use 50% as a conservative estimate of the savings available from the best available technology. Table 10 summarizes the UECs used in the second module of BUENAS.

Table 10. Fan usage characteristics used in BUENAS, by country

Country	Hours/day fan is used	Baseline UEC (kWh)	Efficient UEC (kWh)	Source/Assumption
Australia	0.8	21	10.5	(McNeil et al. 2008)
Brazil	3.4	88	44	(McNeil et al. 2008)
Canada	0.9	11	5.5	Assumes the UEC for EU
South China	8.7	224	112	Assumes the UEC for India
Other China	0.4	10	5	(Letschert et al. 2009)
EU	0.9	11	5.5	(Riviere 2008)
India	8.7	224	112	(Boegle et al. 2010)
Indonesia	5.9	150	75	(McNeil et al. 2008)
Japan	0.8	21	10.5	(McNeil et al. 2008)
Korea	0.8	21	10.5	(McNeil et al. 2008)
Mexico	3.4	88	44	(McNeil et al. 2008)
Russia	0.9	11	5.5	Assumes the UEC for EU
South Africa	3.4	88	44	(McNeil et al. 2008)
U.S	6.2	78	39	(U.S. DOE & U.S. EPA 2010)

Note: Shaded cells are calculated from energy consumption data, assuming a 70W fan

In the third module, BUENAS takes into account first purchase (*FP*) as the increase of fans in the stock from one year to another (resulting from an increase in number of households, which leads to increased penetration of fans) and replacements (*REP*) of fans that are retired from the stock, according to Eq. 4 and Eq. 5:

$$Sales(y) = FP(y) + REP(y) \quad \text{Eq. 4}$$

$$REP(y) = \sum_{age=1}^L Stock(y-1, age) \times P_R(age) \quad \text{Eq. 5}$$

Retirement sales are calculated assuming an average lifetime of 10 years. The probability of retirement (P_R) varies with the age of the fan and is based on a normal distribution around the average lifetime. Table 11 provides the expected sales outputs from BUENAS for 2012 along with the projected growth rate.

Table 11. Sales forecast for 2012, 2030 and annual projected growth rate

	2012	2030	Annual Growth Rate
	Million Devices	Million Devices	%
Australia	1.6	2.0	1.26%
Brazil	10.2	14.5	1.95%
Canada	2.7	3.5	1.32%
China	77.3	94.2	1.10%
EU	28.2	31.4	0.59%
India	38.0	59.5	2.53%
Indonesia	4.8	6.8	2.00%
Japan	7.6	7.7	0.05%
Korea	3.4	4.2	1.13%
Mexico	3.1	3.4	0.66%
Russia	9.2	8.7	-0.31%
South Africa	1.3	1.4	0.60%
U.S.	20.1	25.8	1.41%
Total	207.5	263.2	1.33%

Note: The negative growth in Russia is a result of a decrease in population.

Sales forecasts are combined with annual UECs in both scenarios to arrive at the energy consumption for the stock in every year. The difference between the stock energy consumption in both scenarios equals the energy savings and the CO₂ emissions mitigation potential.

3.2. Results

This section presents the BUENAS results in terms of stock energy consumption and global potential energy savings. BUENAS also provides CO₂ emissions mitigation potential calculated using country-specific carbon factors (McNeil et al. 2008).

3.2.1. Business-As-Usual

Figure 11 presents the global stock energy consumption by country for ceiling fans, estimated by BUENAS in 2012 for the BAU case. The figure shows that China and India represent more than half of worldwide energy consumption by ceiling fans in 2012.

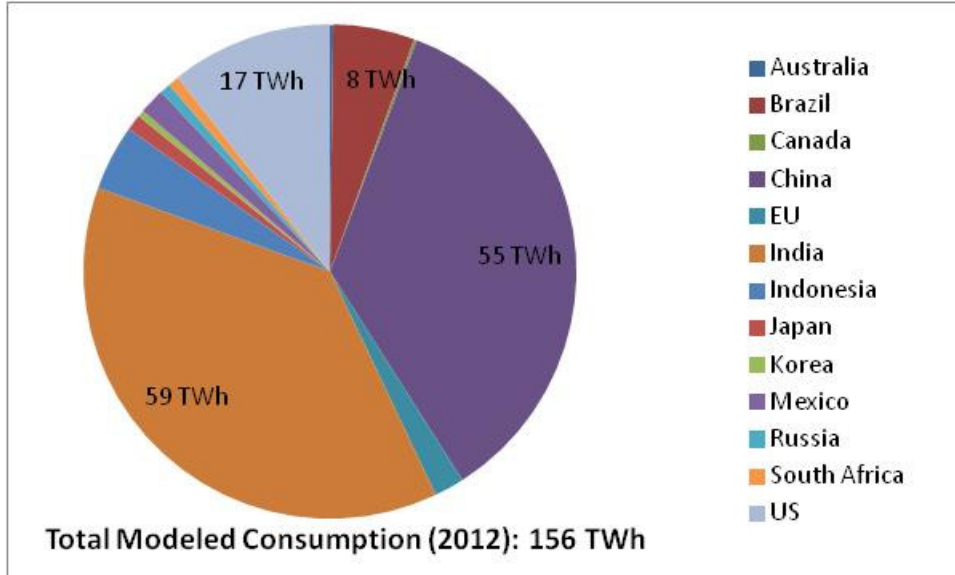

Figure 11. Global Electricity Consumption of Ceiling Fans by Country in 2012

3.2.2. Efficiency Scenario

In the efficiency scenario, efficient fans with BLDC motors enter the market gradually, gaining 20% of market share starting in 2012. The market reaches saturation in 2017 when 100% of fans sold are assumed to be efficient. The UECs for the efficient fans are assumed to be constant throughout the forecast period. We evaluate energy savings potentials in 2016, 2020, and 2030. Table 12 shows the results of the energy savings potential analysis, and Table 13 shows the corresponding CO₂ emissions results. India represents almost half of the potential electricity savings and CO₂ emissions mitigation potential in the economies covered in this analysis.

Table 12. Annual and cumulative energy savings forecasts

Year	Annual Electricity Savings (TWh)			Cumulative Electricity Savings (TWh)		
	2016	2020	2030	2012-2016	2012-2020	2012-2030
Australia	0.05	0.12	0.21	0.12	0.50	2.31
Brazil	1.43	3.35	6.09	3.29	13.83	65.41
Canada	0.05	0.11	0.19	0.11	0.46	2.08
China	9.01	20.68	35.77	21.02	86.50	396.59
EU	0.48	1.08	1.76	1.14	4.59	20.22
India	14.17	33.54	62.38	32.52	137.91	660.60
Indonesia	1.12	2.63	4.81	2.59	10.88	51.51
Japan	0.24	0.54	0.84	0.56	2.27	9.90
Korea	0.11	0.26	0.44	0.26	1.07	4.91
Mexico	0.41	0.93	1.53	0.96	3.90	17.43
Russia	0.15	0.34	0.52	0.37	1.46	6.19
South Africa	0.17	0.40	0.65	0.40	1.67	7.46
U.S.	2.43	5.65	9.86	5.61	23.47	108.57
Total	29.82	69.62	125.05	68.94	288.51	1353.19

Table 13. Annual and cumulative GHG emissions reduction forecasts

Year	Annual CO ₂ Emissions Reduction (Mt)			Cumulative CO ₂ Emissions Reduction (Mt)		
	2016	2020	2030	2012-2016	2012-2020	2012-2030
Australia	0.04	0.10	0.16	0.10	0.41	1.81
Brazil	0.13	0.29	0.52	0.29	1.21	5.66
Canada	0.01	0.02	0.04	0.02	0.09	0.42
China	9.37	21.01	34.31	21.98	89.02	393.57
EU	0.18	0.39	0.59	0.43	1.68	7.08
India	13.09	30.26	53.08	30.22	126.03	581.62
Indonesia	0.79	1.82	3.20	1.83	7.59	35.03
Japan	0.10	0.22	0.31	0.23	0.92	3.85
Korea	0.05	0.11	0.17	0.11	0.46	2.01
Mexico	0.27	0.61	0.99	0.63	2.56	11.36
Russia	0.05	0.10	0.14	0.11	0.44	1.79
South Africa	0.13	0.30	0.43	0.31	1.26	5.30
U.S.	1.43	3.28	5.62	3.36	13.84	62.82
Total	25.64	58.49	99.56	59.63	245.52	1,112.33

Figure 12 and Figure 13 show the annual results between 2000 and 2030. In the efficiency scenario the consumption of fans is stabilized by 2015 and even decreases to the 2010 level by 2020.

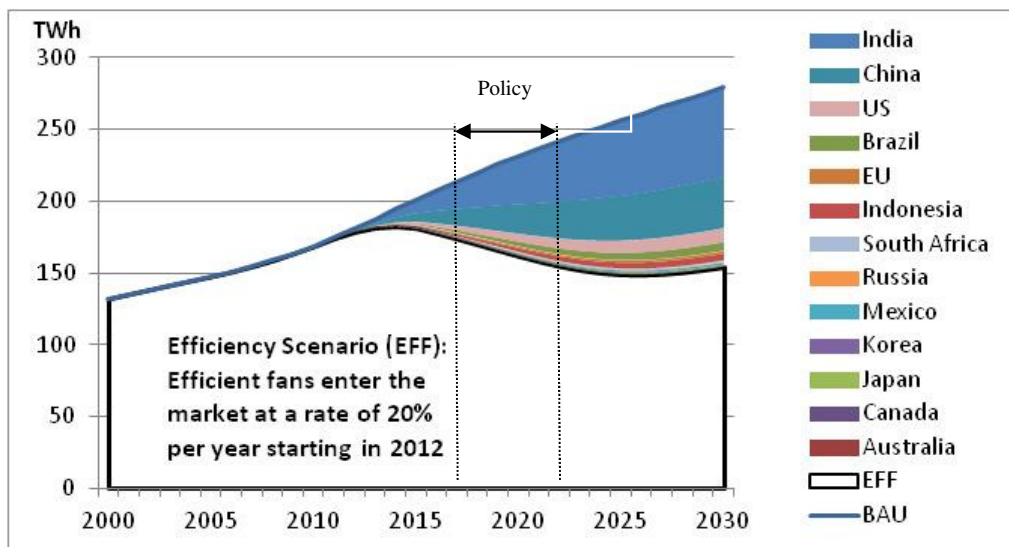

Figure 12. Potential electricity savings resulting from introduction of efficient fans, 2000-2030

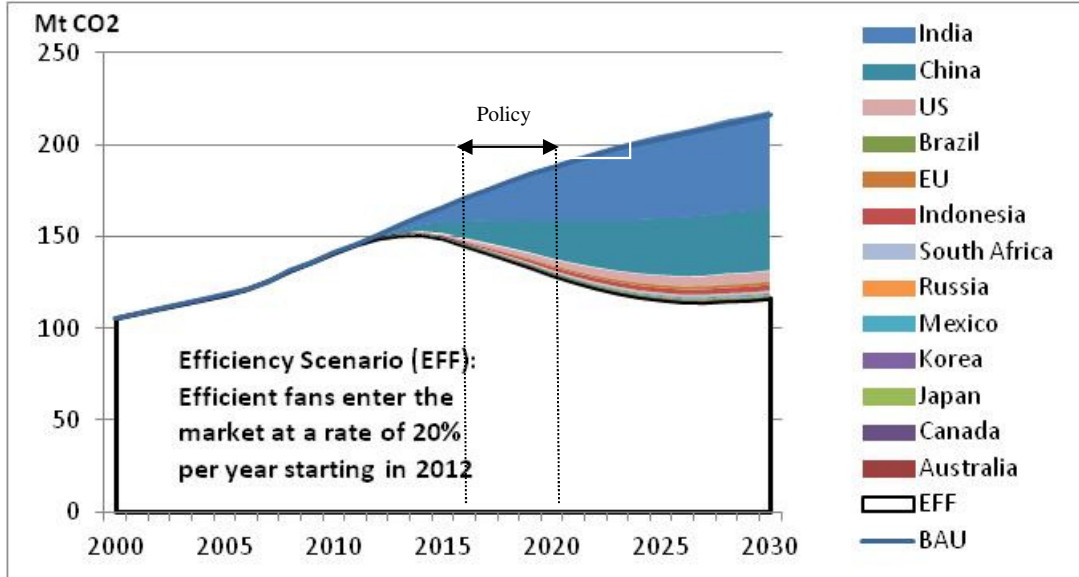

Figure 13. Potential CO₂ emissions reductions resulting from introduction of efficient fans, 2000-2030

4. Ancillary Benefits of Fan Efficiency Improvement

Although improvements in ceiling fan efficiency can greatly reduce direct energy consumption, they can also have ancillary benefits. Specifically, energy-efficient ceiling fans can help reduce the global growth in energy demand for cooling while enhancing the standard of living in less developed regions and low income households. We discuss such ancillary benefits in this section.

The most tangible benefit of ceiling fans may not have to do with costs, energy consumption, or GHG emissions but rather their contribution to sustainable development. Fans are thought to improve survivability levels of low-income households (Santamouris et al. 2007). They are uniquely suited to contribute to the sustainable development of rural households, especially those that are less likely to have electricity service from a reliable transmission grid. In power-constrained situations such as this, reducing the power demand of appliances can enhance the standard of living by allowing for increased adoption of appliances (Fulkerson et al. 2005). This is likely to be especially true for ceiling fans in households in warm climates, as indicated by the significant growth in ownership of ceiling fans where electrification rates have increased, for example in Karnataka, India (Murthy et al. 2001). The same is likely to be true in many off-grid rural areas that depend on isolated power sources such as solar photovoltaic (PV) technologies (Chaurey & Kandpal 2010), PV-diesel hybrid systems (Bala & Siddique 2009; Mondal & Denich 2010), and biomass gasifiers (Kumar & Banerjee 2010). The combination of PV with a BLDC fan motor can be especially beneficial because PV produces DC current, which is the input needed for the BLDC motor controller. This eliminates the costs of a rectifier (Levy 2009), which is typically needed to convert household AC current to DC current for the BLDC motor. Therefore, a super-efficient ceiling fan can considerably reduce the wattage need of a solar home system, which would increase the marketability of solar home ceiling fan systems. For example, the cost of a combined PV-fan system could be reduced by around US\$500 for a drop in ceiling fan power demand from 70 to 25 W, under the assumption that the current cost for rural solar PV installation is about US\$11.1 per watt-peak (Harish & Raghavan 2011).¹⁴

Between 2010 and 2030, the developing world is predicted to increase its energy consumption from residential air conditioning by over 350% (McNeil & Letschert, 2008) and the sales of room air conditioners (RACs) in Europe are anticipated to increase by 53% (Ecodesign 2008). Globally, the emissions from electricity generation produced to power these air conditioners will contribute significantly to the rapidly growing stock of carbon in the atmosphere. On a regional scale, hot summer days have resulted in national power shortages (Lin & Rosenquist, 2008) and increased wholesale electricity prices. Although much work is under way to increase the efficiency of air conditioners (Navigant Consulting 2010), effort has also been directed toward

¹⁴ 50W savings x \$11.1=\$555. The incremental costs for this improvement in fan efficiency would work out to about ~\$30, based on the cost data presented in section 2.3.

the development of passive cooling techniques, in which ceiling fans are an essential feature (S. Ho et al. 2009; James et al. 1996). Studies such as Schiavon & Melikov (2008) have estimated energy savings and improved thermal comfort resulting from increased air movement from simulations of an indoor office located in European and Mediterranean cities with various summer outdoor climate conditions. Results indicate the potential for an 8 to 15% reduction in maximum cooling power requirements for an indoor air velocity of 0.5 meters/second (m/s), and a 12 to 22% reduction for a velocity of 0.8 m/s. (Arens et al. 2009) present results of surveys regarding preference for cooler temperature versus air movement from field studies of occupant comfort in buildings worldwide. These results indicate significant potential for reducing energy consumption from air conditioners through ceiling fan use while limiting air velocity to a comfortable range. In particular, for temperatures above about 22.5 °C, there is a strong preference for air movement and little risk of drafts negatively affecting comfort.

Although ceiling fans can play a significant role in reducing energy consumption in many countries, an important consideration that is often overlooked is thermal comfort from differing forms of cooling systems. Thermal comfort is affected by heat exchange between the human body and its environment. Six main factors contribute to this heat exchange: conduction, convection, radiation, moisture, clothing, and metabolic effects (Djongyang et al. 2010). Air movement primarily affects the convective effect, which is represented by Eq. B. 1. Specifically, air movement increases the heat-transfer coefficient h , which is a function of air velocity, as shown in Appendix B. This is in contrast to the effect of an air conditioner, which affects the ambient temperature (T_a) and in turn skin temperature (T_{sk}). Thus, from an energy-efficiency perspective, the questions are how much energy consumption is needed for ceiling fans to affect h , versus T_{sk} (for air conditioning), and what is the optimal level of h and T_{sk} that minimizes energy consumption while maximizing comfort. A complete answer to these questions would require further empirical work in specific contexts where cooling systems are used. Therefore, we only provide a brief theoretical discussion of the effects of air speed on the convective heat flux of a human body in Appendix B.

5. Realizing cost-effective efficiency improvements: lessons for market transformation programs

As discussed earlier in Section 2 of this report, there are several cost-effective options to improve ceiling-fan efficiency that would reduce fan energy consumption by more than 50%. Although highly efficient fans that incorporate most of the efficiency improvement options discussed in this paper are commercially available in certain countries (e.g., the U.S.), they constitute a very small percentage of sales. In some countries (e.g., India), fans with BLDC motors and efficient blades are not currently commercially available. Several barriers, including high first cost and lack of information (e.g., lack of labels that recognize highly efficient performance), have been identified that contribute to the limited adoption of highly efficient fans (Singh et al. 2010). In this section we discuss some broad insights for energy efficiency market transformation programs, based on the earlier discussion.

5.1. General Insights

Some of the insights that can be drawn from the preceding discussion apply across the various types of market transformation programs and policies. Here we discuss some such general insights, with respect to key fan characteristics such as fan size and speed, and with respect to blade design.

It is important for market transformation programs to classify fans by size and take into account the effect of fan speed on efficacy, as follows:

First, fan size categories are important in market transformation programs to preclude the possibility that a policy based merely on efficacy could be circumvented simply by increasing blade length, without necessarily delivering better service. For instance, although airflow increases with larger blades, the amount of cooling felt by the user may not, because the service delivered to the final user (in this case cooling) depends not on the total volume of air moved, but also on the velocity of the air¹⁵ as discussed further in Appendix B. If market transformation policies classify fans by size, fan manufacturers will not be able to simply install longer blades to improve efficacy nominally, without competing with other manufacturers in a separate size category, or improving the service delivered to the final user. *Second*, operating speed is also an important criterion in designing market transformation programs, because efficacy varies inversely with increasing fan speed as discussed in Appendix C. This effect can be addressed either by using a standard speed or minimum airflow in the test procedure for the program such as in India's standard and labeling programs, or by changing the efficacy requirement at various speeds, such as in the ENERGY STAR program. It should be noted that the testing burden would be lower in the first case, with a tradeoff on the accuracy of the test procedure, at various speeds.

¹⁵The coefficient of convective heat transfer off the human body depends on the velocity of the air. (Incropera and DeWitt, 1998)

The literature discussed in Section 2.2.2 indicate that there is remarkable potential for energy-efficiency improvements from changes in fan blade design and also imply that blade design improvements have greater efficacy/power consumption savings impact at higher speeds. This implies that market transformation programs in economies with hotter climates and higher average airflows (e.g. India) will benefit proportionally more from blade design improvements than economies where average airflows tend to be lower. (e.g. the US). For example, the most efficient blade designs discussed in the literature will improve efficacy by 86% at lower speeds (airflows), versus 111% at higher speeds (airflows) compared with conventional blade designs. (Parker et al. 2000).

5.2. Standards and Labeling Programs

Out of the several types of policies typically used to accelerate adoption of efficient products (e.g., awards, incentives, and standards and labeling programs), standards and labeling programs appear to be most commonly used to move the market towards higher efficiency by pushing inefficient fans off the market. However, as will be discussed below, levels specified by standards and labeling programs are far below what can be achieved by implementing cost-effective energy-efficiency options in ceiling fans (see Figure 13). For example, as seen from data on the efficacy of the fans meeting the US Energy Star requirement (see Figure 7 and Figure 8 in section 2.2.3), fans using BLDC motors and efficient blades are significantly more efficient (with efficacy as high as $15 \frac{m^3}{min}/W$) compared to efficiency requirement for qualifying for Energy Star (efficacy of $2.1-4.2 \frac{m^3}{min}/W$). Furthermore, BEE's voluntary star rating program for fans only covered 2% of the Indian market, while only 18% of the fans (without a light kit) on the US ceiling fan market were compliant with ENERGY STAR (PWC, 2012, and EPA 2011) indicating significant room for efficiency improvement. We discuss the implications of the cost-effective efficiency improvement options for standards and labeling programs.

The standards and labels levels for BEE's star rating program in India are presented in Figure 13. These efficacy levels are tested under different conditions (notably airflow requirements/speeds) than standards and labels in the US, Europe and China so they cannot be directly compared against each other without accounting for this fact.¹⁶ However, the improvements in efficacy discussed in this report are applicable across the range of commonly encountered airflows. i.e. these improvements will offer significant energy savings of a similar order of magnitude regardless of airflow, and test procedure alignment. For comparison, the US ENERGY STAR label has an efficacy requirement of $4.2 (m^3/min/W)$ at -low speeds and $2.1 (m^3/min/W)$ at -high speeds while the lowest standard for efficacy in China varies by fan size from $3.47 (m^3/min/W)$

¹⁶ See Appendix C for a discussion of the effect of fan speed on efficacy. Increasing airflow from 5000 CFM (the US high speed) to 7415 CFM (i.e. $210 m^3/min$, the minimum airflow for star rated fans in India), i.e. A 48% increase will yield a decrease in efficacy of at most 35%.

for 1800 mm fans to 2.75 (m³/min/W) for 900 mm fans. (U.S. DOE & U.S. EPA, 2010, and AQSIQ, 2010). Figure 13 makes clear the significant potential for improvement in fan efficacy through increases in specified standards and labels.

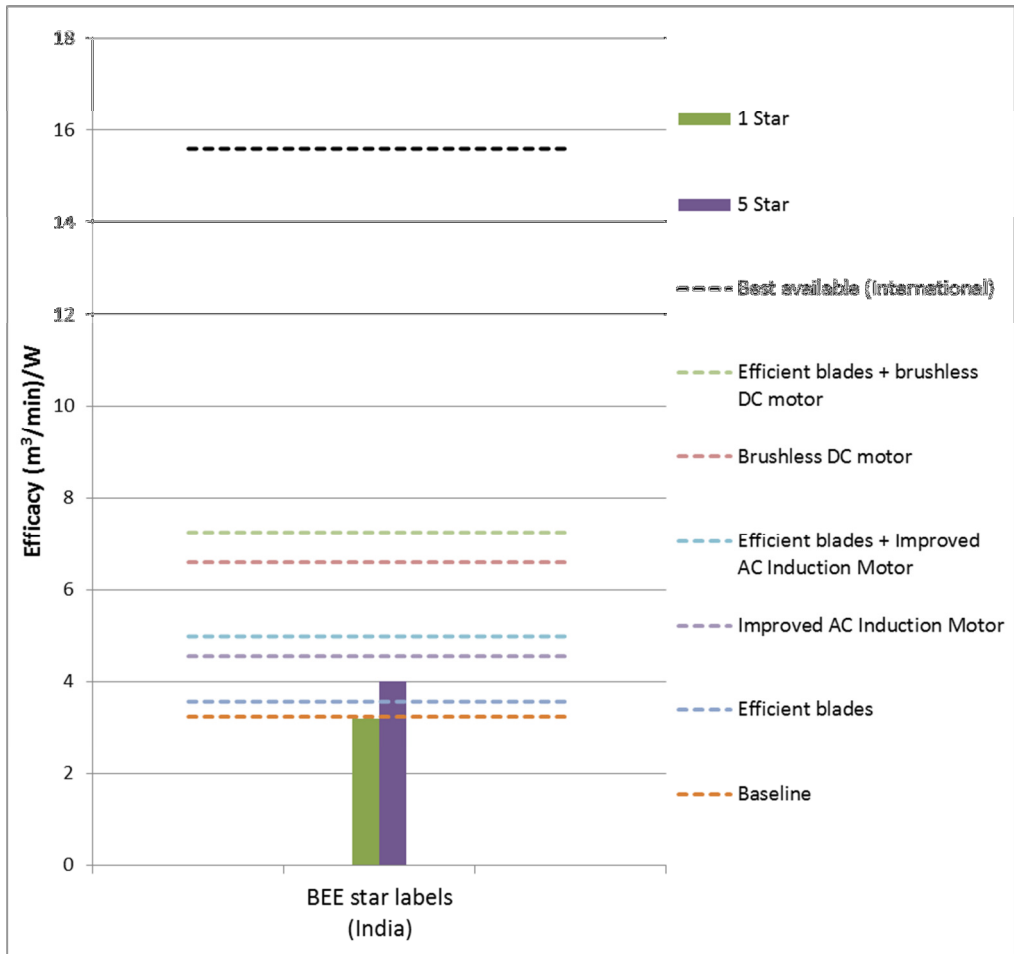

Figure 14. BEE (India) star labels compared to estimates of potential ceiling fan efficacy¹⁷

Thus, the highest efficacy level recognized by labels in several countries is significantly lower than what can be achieved by adopting cost effective efficiency options. Hence current efficacy label levels need to be revised significantly to encourage deeper penetration of efficient ceiling fans at the top of the market with efficacies achievable using BLDC motors and efficient blades that are already on the market in the US, and that are cost-effective in other countries. The low penetration levels of efficient ceiling fans in both India and the US (discussed earlier in this

¹⁷ Note: The baseline efficacy value is based on the average values reported as ‘National Player’s Models’ presented in (Garg & Jose 2009). Incremental improvements correspond to those presented in section 2.2. The efficacy level of the best available fan corresponds to the fan with the highest efficacy in Figure 8 in section 2.2.3.

section) seems to indicate the presence of barriers to efficiency other than information, such as first cost, that may not be able to be addressed within a standards and labeling framework.

5.3. Incentive Programs

Incentive programs for efficient fans could accelerate the penetration of superefficient fans for the following reasons: First, adoption of cost-effective efficient appliances is often hindered by high first cost, e.g. as discussed in Reddy (1991). In emerging economies, consumers are highly sensitive to high first costs (Singh et al. 2010). Second, due to the tradeoffs with respect to aesthetics discussed in section 2.2.2 and 2.3.2, it is not practical or desirable to mandate efficiency improvement from blade design through MEPS. However, the full existing potential from more efficient blades as well as from BLDC motors could be exploited through incentive programs for superefficient fans. Such programs could cost effectively target efficacies of up to $15 \frac{m^3}{min}/W$, as discussed in section 2.2 and 2.3 earlier.

There are several examples of financial incentive programs that lower the first cost of cost-effective energy efficient appliances and equipment to accelerate their adoption. However, despite the large saving potential, financial incentive programs to promote the adoption of highly efficient fans are not common.

One notable example under development is the Super-Efficient Equipment Program (SEEP) in India where financial incentives will be provided to fan manufacturers to produce and sell highly efficient fans that consume less than half of the energy consumed by fans typically sold on the Indian market (Singh et al. 2010). Even if the entire incremental cost of the highly efficient fans is covered by the financial incentives, the cost of the conserved electricity for efficiency improvements over 50% is just Rs. 1.4 per kWh (\$0.027/kWh) which is about one third of the cost of supplying electricity in India (J. Sathaye & Gupta 2010). This program has the potential to save peak power of nearly 5,000 MW in the next five years. It is quite likely that a financial incentive program accelerating the penetration of highly efficient fans has a large cost effective saving potential in several other countries and should be considered as one of the key options for reducing electricity demand and emissions.

6. Conclusions

This paper presents an analysis of the potential for improving ceiling fan components to reduce global energy consumption and GHG emissions. Improved blade design and AC induction motor materials, and the increased use of BLDC motors are identified as cost effective options to improve the efficiency of ceiling fans that could provide ceiling fan power consumption savings of more than 50% in many countries.

Out of the several types of policies typically used to accelerate adoption of efficient products (e.g., awards, incentives, and standards and labeling programs), standards and labeling programs are the most commonly used to accelerate the market penetration of efficient fans.

Efficacy levels are tested under different conditions (notably airflow requirements/speeds) in various countries so they cannot be directly compared against each other without accounting for this fact. Nevertheless, the improvements in efficacy discussed in this report are applicable across the range of commonly encountered airflows. i.e. these improvements will offer significant energy savings of a similar order of magnitude regardless of airflow, and test procedure alignment.

The highest efficacy level required by standards and labeling programs in several countries is significantly lower than what can be achieved by adopting the cost effective efficiency improvement options discussed here. Hence current efficacy label levels need to be revised significantly to encourage deeper penetration of efficient ceiling fans at the top of the market with efficacies achievable using BLDC motors and efficient blades that are already on the market in the US, and that are cost-effective.

The low penetration levels of efficient ceiling fans in both India and the US even with labeling programs in place¹⁸ seems to indicate the presence of barriers to efficiency in addition to information, such as first cost, that may not be able to be addressed fully within a standards and labeling framework, particularly in emerging economies with price sensitive consumers. However, despite the large saving potential, financial incentive programs to promote the adoption of highly efficient fans by removing this first cost barrier are not common.

One notable example under development is the Super-Efficient Equipment Program (SEEP) in India where financial incentives will be provided to fan manufacturers to produce and sell highly efficient fans that consume less than half of the energy consumed by fans typically sold on the Indian market (Singh et al. 2010). Even if the entire incremental cost of the highly efficient fans is covered by the financial incentives, the cost of the conserved electricity for efficiency

¹⁸ BEE's voluntary star rating program for fans only covered 2% of the Indian market, while only 18% of the fans (without a light kit) on the US ceiling fan market were compliant with ENERGY STAR (PWC, 2012, and EPA 2011) indicating significant room for efficiency improvement.

improvements over 50% is just Rs. 0.7 per kWh (\$0.014/kWh) which is about one sixth of the cost of supplying electricity in India (J. Sathaye & Gupta 2010). SEEP or a similar upstream incentive program for ceiling fans would be cost-effective even assuming higher costs and lower hours of use as discussed in section 2.3.

This program has the potential to save peak power of nearly 5,000 MW in the next five years. It is quite likely that a financial incentive program accelerating the penetration of highly efficient fans has a large cost effective saving potential in several other countries and should be considered as one of the key policy options for reducing electricity demand and emissions. Detailed cost effectiveness estimates for other economies are presented in Appendix D.

Therefore there remains significant scope for improved policy design and implementation for aggressive and cost effective ceiling fan efficiency improvements.

References

- Aavaas, 2011. A Platform for Indian Homemakers. Available at: <http://htoh.wordpress.com/category/living-room/> [Accessed July 26, 2011].
- Arens, E. et al., 2009. Moving Air for Comfort. *ASHRAE Journal*, 51(5), pp.18-28.
- Bala, B. & Siddique, S., 2009. Optimal design of a PV-hybrid system for electrification of an isolated island - Sandwip in Bangladesh using genetic algorithm. *Energy for Sustainable Development*, 13(3), pp.137-142.
- Bassiouny, R. & Korah, N., 2011. Studying the features of air flow induced by a room ceiling-fan. *Energy and Buildings*, 43(8), pp.1913-1918.
- Bird, G., 2004. High Efficiency Ceiling Fan. *United States Patent*, Number 6733241.
- Boegle, A., Singh, D. & Sant, G., 2010. Estimating Technical Energy Saving Potential from Improving Appliance Efficiency in Indian Households. In *ACEEE Summer Study on Energy Efficiency in Buildings*. The Climate for Efficiency is Now. Pacific Grove, CA.
- Bullock, R.O. "Analysis of Reynolds Number and Scale Effects on Performance of Turbomachinery" *ASME Journal of Engineering for Power*, 1964
- Bureau of Indian Standards, 2007. Indian Standard - Specification for Electric Ceiling Type Fans and Regulators (3rd Revision), Edition 4.6, (Incorporating Amendment Nos 1-6).
- Calwell, C. & Horowitz, N., 2001. Ceiling Fans: Fulfilling the Energy Efficiency Promise. *Home Energy*, 18(1), pp.24-30.
- Carter, A. D. S. , Moss, C.E. , Green, G. R. and Annear, G.G., "The Effect of Reynolds Number on the Performance of a Single-Stage Compressor" , *Aeronautical Research Council Reports and Memoranda*, 1960.
- Carter, A. D. S. "Blade Profiles for Axial-Flow Fans, Pumps, Compressors, Etc" *Proceedings of the Institution of Mechanical Engineers* June 1961 vol. 175 no. 1 775-806
- Chakraborty, A. et al., 2004. Energy Conservation in Ceiling Fans. In *Proceedings of the 13th National Power Systems Conference*. National Power Systems Conference. Chennai, pp. 835-838.
- Chaurey, A. & Kandpal, T., 2010. Assessment and evaluation of PV based decentralized rural electrification: An overview. *Renewable and Sustainable Energy Reviews*, 14(8), pp.2266-2278.
- Chiang, Justin, Fairchild Semiconductor, September 16, 2010, Power point presentation, Available at: <http://edg1.vcall.com/irwebsites/fairchildsemi/Final%20-%20PCIA.pdf>

Davis Energy Group Energy Solutions, 2004 “Codes and Standards Enhancement Initiative For PY2004: Title 20 Standards Development: Analysis of Standards Options for Ceiling Fans”

Desroches, L.-B. & Garbesi, K., 2011. *Max Tech and Beyond: Maximizing Appliance and Equipment Efficiency by Design*, Berkeley, CA: Lawrence Berkeley National Laboratory.

Djongyang, N., Tchinda, R. & Njomo, D., 2010. Thermal comfort: A review paper. *Renewable and Sustainable Energy Reviews*, 14(9), pp.2626-2640.

Dutt, G. & Mills, E., 1994. Illumination and sustainable development Part II: Implementing lighting efficiency programs. *Energy for Sustainable Development*, 1(2), pp.17-27.

Ecodesign. 2008. *Preparatory study on the environmental performance of residential room conditioning appliances (airco and ventilation), Draft Report of Task 2.* http://www.ebpg.bam.de/de/ebpg_medien/tren10/010_studyf_08-07_airco_part2.pdf.

Emerson Climate Technologies, 2010. *Midway Eco*, <http://www.emersonfans.com/Pages/Fan.aspx?Fan=Midway%20Eco> Accessed 12/15/2010.

ENERGY STAR. (2011). ENERGY STAR Unit Shipment and Market Penetration Report Calendar Year 2010 Summary. http://www.energystar.gov/ia/partners/downloads/unit_shipment_data/2010_USD_Summary_Report.pdf

ENERGY STAR. 2012a. ENERGY STAR Ceiling Fan Product List posted on November 14, 2012.

http://www.energystar.gov/index.cfm?fuseaction=find_a_product.showProductGroup&pgw_code=CF

ENERGY STAR. 2012b. ENERGY STAR Ceiling Fan (With Light Kit) Product List posted on November 14, 2012.

http://www.energystar.gov/index.cfm?fuseaction=find_a_product.showProductGroup&pgw_code=CF

ENERGY STAR. 2012c. ENERGY STAR Unit Shipment and Market Penetration Report Calendar Year 2011 Summary.

http://www.energystar.gov/ia/partners/downloads/unit_shipment_data/2011_USD_Summary_Report.pdf

European Commission, 2010. Commission Working Document on possible Ecodesign Requirements for air-conditioning appliances and comfort fans. Available at: http://www.eup-network.de/fileadmin/user_upload/Produktgruppen/Lots/Working_Documents/Lot_10_Air-Con_April_2010/WD_Airco_Ecodesign_Regulation_for_CF.pdf [Accessed July 26, 2011].

Fulkerson, W. et al., 2005. Sustainable, efficient electricity service for one billion people. *Energy for Sustainable Development*, 9(2), pp.26-34.

Garg S. and Jose A. "Energy Efficiency Labelling of Ceiling Fans in India: Challenges

- and the way forward." Proceedings of the 5th International Conference on Energy Efficiency in Domestic Appliances and Lighting, 2009
http://www.enbook.pl/sites/default/files/publikacje/150/20120130/energy_efficiency_in_domestic_vol_3_p2.pdf
- Geller, H. et al., 2006. Policies for increasing energy efficiency: Thirty years of experience in OECD countries. *Energy Policy*, 34(5), pp.556-573.
- General Administration of Quality Supervision Inspection and Quarantine of the People's Republic of China,(AQSIQ) 2010. *Minimum allowable values of energy efficiency and energy efficiency grades of AC electric fans GB 12021.9-2008*, Standardization Administration of the People's Republic of China.
- Gossamer Wind, 2011. *What is So Special About These Fans*,
<http://www.gossamerwind.com/content/what-so-special-about-these-fans-0> Accessed 4/20/2011.
- Harish, S. & Raghavan, S., 2011. Resdesigning the National Solar Mission for Rural India. *Economic and Political Weekly*, XLVI(23), pp.51-58.
- Ho, S., Rosario, L. & Rahman, M., 2009. Thermal comfort enhancement by using a ceiling fan. *Applied Thermal Engineering*, 29(8-9), pp.1648-1656.
- Hwang, R.-L. et al., 2009. Thermal perceptions, general adaptation methods and occupant's idea about the trade-off between thermal comfort and energy saving in hot-humid regions. *Building and Environment*, 44(6), pp.1128-1134.
- shutterstock images, 2011. Available at: <http://www.shutterstock.com/pic-267108/stock-photo--d-person-sitting-on-a-sofa.html> [Accessed July 26, 2011].
- Incropera, Frank and DeWitt, David, "Fundamentals of Heat and Mass Transfer", 4th Edition, 1998.
- James, P. et al., 1996. Are Energy Savings Due to Ceiling Fans Just Hot Air. In *ACEEE Summer Study Proceedings Paper*. Profiting From Energy Efficiency. Pacific Grove, CA.
- Koomey, J. et al., 2010. Defining a standard metric for electricity savings. *Environmental Research Letters*, 5.
- Kumar, M. & Banerjee, R., 2010. Analysis of isolated power systems for village electrification. *Energy for Sustainable Development*, 14(3), pp.213-222.
- Lin, J., & G. Rosenquist. 2008. "Stay cool with less work: China's new energy-efficiency standards for air conditioners". *Energy Policy* 36: 1090–1095.

Letschert, V. & McNeil, M., 2008. *The Boom of Electricity Demand in the Residential Sector in the Developing World and the Potential for Energy Efficiency*, Berkeley, CA: Lawrence Berkeley National Laboratory.

Letschert, V., McNeil, M. & Zhou, N., 2009. Residential Electricity Demand in China - Can Efficiency Reverse the Growth? *LBNL-2321E (Proceedings of the 5th International Conference on EEDAL 2009. Berlin, Germany Energy Agency)*.

Levy, S., 2009. Why DC Power is the Next Wave in Power Generation, Storage and Applications. *Tennessee Solar Association*.

Liu, C.-S. et al., 2009. Development of New Structure of BLDC Servo Motor for Ceiling Fan. In *Proceedings of the 4th IEEE Conference on Industrial Electronics and Appliances*. 4th IEEE Conference on Industrial Electronics and Appliances. pp. 2640-2643.

de M. Jannuzzi, G. & dos Santos, V., 1996. Costs and benefits of a utility rebate program to promote compact fluorescent lamps in Brazilian households. *Energy for Sustainable Development*, 2(6), pp.53-56.

McNeil, M. A., & V. E. Letschert. 2008. *Future Air Conditioning Energy Consumption in Developing Countries and what can be done about it: The Potential of Efficiency in the Residential Sector*. Berkeley, Calif: Lawrence Berkeley National Laboratory.

McNeil, M. & Letschert, V., 2007. Future Air Conditioning Energy Consumption in Developing Countries and what can be done about it: The Potential of Efficiency in the Residential Sector. In *Proceedings of the ECEEE 2007 Summer Study*. ECEEE 2007 Summer Study. Cote d'Azur, France.

McNeil, M., Letschert, V. & De la Rue du Can, S., 2008. *Global Potential of Energy Efficiency Standards and Labeling Programs*, Berkeley, CA: Lawrence Berkeley National Laboratory.

McNeil, M., Letschert, V.E., de la Rue du Can, S., Ke, J., 2012. Bottom-Up Energy Analysis System – Methodology and Results. Lawrence Berkeley National Laboratory – LBNL 5722E

Mondal, A. & Denich, M., 2010. Hybrid systems for decentralized power generation in Bangladesh. *Energy for Sustainable Development*, 13(1), pp.48-55.

Murthy, N., Sumithra, G. & Reddy, A., 2001. End-uses of electricity in households of Karnataka state, India. *Energy for Sustainable Development*, 5(3), pp.81-94.

Navigant Consulting, 2010. Max Tech and Beyond: Residential Air Conditioning Equipment.

NPD Intellect, LLC, (2012) Consumer survey data 2004-2006, Port Washington, NY

- NPD Intellect, LLC,(2011) Consumer survey data 2007-2011, Port Washington, NY
- Obeng, G. & Evers, H.-D., 2010. Impacts of public solar PV electrification on rural micro-enterprises: The case of Ghana. *Energy for Sustainable Development*, 14(3), pp.223-231.
- Parker, D., 2010. Personal Communication at Florida Solar Energy Center.
- Parker, D. & Hibbs, B., 2010. Efficient Traditionally Appearing Ceiling Fan Blades with Aerodynamical Upper Surfaces. *United States Patent*, Number 7665967.
- Parker, D. et al., 1999. *Development of a High Efficiency Ceiling Fan "The Gossamer Wind,"* Tallahassee, FL: Florida Energy Office, Department of Community Affairs.
- Parker, D., Hua, G. & Hibbs, B., 2007. Enhancements to High Efficiency Ceiling Fan. *United States Patent*, Number 6039541.
- Parker, D., Hua, G. & Hibbs, B., 2000. High Efficiency Ceiling Fan. *United States Patent*, Number 6039541.
- Parker, D., Su, G. & Hibbs, B., 2003. High Efficiency Ceiling Fan Blades. *United States Patent*, Number 6659721.
- Pednekar, A., 2010. Personal Communication.
- Phadke, A., 2010. Leveraging Global Supply Chains to Accelerate the Deployment of Super-Efficient Appliances: An Upstream Global Strategy. In *The Climate for Efficiency is Now*. ACEEE Summer Study on Energy Efficiency in Buildings. Pacific Grove, CA.
- PWC (Price Waterhouse Coopers), "Design of Monitoring and Verification Systems for SEEP for Fans- Inception Report"-unpublished draft, 2012.
- Reddy, A., 1991. Barriers to improvements in energy efficiency. *Energy Policy*, 19(10), pp.953-961.
- Riviere, P., 2008. Preparatory study on the environmental performance of residential room conditioning appliances (airco and ventilation). Study on comfort fans -final report. Available at: http://www.ebpg.bam.de/de/ebpg_medien/010_studyf_08-11_comfortfans_parts1-8.pdf [Accessed July 26, 2011].
- de la Rue du Can, S. et al., 2009. *Residential and Transport Energy Use in India: Past Trend and Future Outlook*, Berkeley, CA: Lawrence Berkeley National Laboratory.
- Santamouris, M. et al., 2007. Recent progress on passive cooling techniques: Advanced technological developments to improve survivability levels in low-income households. *Energy and Buildings*, 39(7), pp.859-866.

- Sathaye, J. & Gupta, A., 2010. Eliminating Electricity Deficit through Energy Efficiency in India: An Evaluation of Aggregate Economic and Carbon Benefits. *LBNL-3381E*.
- Sathaye, J. et al., 2009. Opportunities to change development pathways toward lower greenhouse gas emissions through energy efficiency. *Energy Efficiency*, 2(4), pp.317-337.
- Sathaye, N., 2011. Personal Communication.
- Sauer, I. et al., 2001. Demand-side management for the residential sector of the San Jose, Costa Rica, metropolitan region. *Energy for Sustainable Development*, 5(3), pp.60-80.
- Schiavon, S. & Melikov, A., 2008. Energy saving and improved comfort by increased air movement. *Energy and Buildings*, 40(10), pp.1954-1960.
- Schmidt, K. & Patterson, D., 2001. Performance results for a high efficiency tropical ceiling fan and comparisons with conventional fans: Demand side management via small appliance efficiency. *Renewable Energy*, 22(1-3), pp.169-176.
- Schneider Electric, 2011. Available at: <http://products.schneider-electric.us/products-services/product-detail/?event=productDetail&countryCode=us&partNumber=SLSWDS1500> [Accessed July 26, 2011].
- Shensheng, L., Yanjia, W. & Qun, L., 1996. The program of green lighting in China. *Energy for Sustainable Development*, 3(3), pp.37-40.
- Singh, D., Barve, A. & Sant, G., 2010. *Ceiling Fan The Overlooked Appliance in Energy Efficiency Discussions*, Pune, India: Prayas Energy Group.
- Sonne, J. & Parker, D., 1998. Measured Ceiling Fan Performance and Usage Patterns: Implications for Efficiency and Comfort Improvement. In *ACEEE Summer Study on Energy Efficiency in Buildings*. Energy Efficiency in a Competitive Environment. Pacific Grove, CA, pp. 335-341.
- U.S. DOE & U.S. EPA, 2010. Energy Star. Available at: <http://www.energystar.gov/> [Accessed July 26, 2011].
- Volk, S., 1990. Propeller Breeze Enhancing Blades for Conventional Ceiling Fans. *United States Patent*, Number 4892460.
- Waide, P. et al., 2011. Opportunities for Success and CO2 Savings from Appliance Energy Efficiency Harmonisation. *Navigant Consulting in Partnership with CLASP*. Available at: <http://www.clasponline.org/clasp.online.resource.php?disdoc=781#opportunities> [Accessed July 26, 2011].

Wei, M., Patadia, S. & Kammen, D., 2010. Putting renewables and energy efficiency to work: How many jobs can the clean energy industry generate in the US? *Energy Policy*, 38(2), pp.919-931.

Wright, T. & Gerhart, P., 2010. *Fluid machinery Application, Selection, and Design*, CRC Press.

Appendix A. Fan Laws

The *fan laws* in the similitude branch of the fluid mechanics and machinery literature (Wright & Gerhart 2010) provide simple performance equations for ceiling fans as a function of basic variables. The purpose of this appendix is to use these laws to guide policy rather than conducting a detailed numerical analysis. The laws have traditionally been used to assess the performance of prototype turbomachinery through smaller-scale models based on dimensional and empirical analysis. Accordingly, these laws can also be used to assess the performance of two similar machines, for example, two ceiling fans. The laws are presented in Eq. A.1 and Eq. A.2.

For the purposes of this paper we have made the following simplifying assumptions: 1) that air density is the same for the two ceiling fans being compared through the laws, and 2) that the density of air does not change greatly as it passes through a ceiling fan (i.e., that the flow is incompressible). In addition, we assume that motor efficiency is constant. We have addressed motor efficiency separately in section 2.3.1. Eq A.3 is an equation for efficacy, which is a result of Eq. A.2 being divided by Eq. A.1.

$$P = S^3 D^5 \quad \text{Eq. A.1}$$

$$Q = S D^3 \quad \text{Eq. A.2}$$

$$Q/P = S^{-2} D^{-2} \quad \text{Eq. A.3}$$

Where:

$P = p_a/p_b$ = ratio of power demands for two similar fans being compared, denoted by subscript a and b

$S = s_a/s_b$ = ratio of speeds

$D = d_a/d_b$ = ratio of diameters

$Q = q_a/q_b$ = ratio of airflows

$Q/P = \frac{q_a/p_a}{q_b/p_b}$ = ratio of efficacies

The laws represent the operational similarity between two fans that are similar in design and construction but differ in the variables P, S, D and Q . Rotation speed and downward air speed are linearly correlated; therefore, we simply use “speed” in the discussion in the remainder of this appendix.

Based on these laws, Table 14 presents proportional relationships between various variables for two similar fans. The first two columns of Table 14 show relationships that indicate how changes with respect to one variable influence performance while other variables are held constant. We

specify some variables to be held constant for each proportional relationship because this allows us to assess the influence of the change in S or D on a particular performance characteristic. The variables held constant for each relationship are shown in the third and fourth columns of Table 14. The last two columns of the table show the equations and corresponding numbers, which are used to derive the proportional relationships in the first two columns. These equations are the result of algebraic manipulation of the fan laws.

Table 14 Ceiling fan similitude relationships, which provide proportional relation between design variables and performance characteristics

Proportional relationship:		Constant:		Corresponding equation:	
$S^3 \propto P$	Effect of speed on power	D	Fan size	$P = S^3 D^5$	Eq. A.1
$S \propto Q$	Effect of speed on airflow	D	Fan size	$Q = S D^3$	Eq. A.2 Eq. A.2
$S^{-2} \propto Q/P$	Effect of speed on efficacy	D	Fan size	$Q/P = S^{-2} D^{-2}$	Eq. A.3
$D^{-4} \propto P$	Effect of fan size on power	Q	Airflow	$P = Q^3 D^{-4}$	Eq. A.4
$D^4 \propto Q/P$	Effect of fan size on efficacy	Q	Airflow	$Q/P = Q^{-2} D^4$	Eq. A.5
$D^{-3} \propto S$	Effect of fan size on speed	Q	Airflow	$S = Q D^{-3}$	Eq. A.2 Eq. A.2
$D^5 \propto P$	Effect of fan size on power	S	Speed	$P = S^3 D^5$	Eq. A.1 Eq. A.1
$D^{4/3} \propto Q/P$	Effect of fan size on efficacy	P	Power	$Q/P = P^{-2/3} D^{4/3}$	Eq. A.6
$D^{-5/3} \propto S$	Effect of fan size on speed	P	Power	$S = P^{1/3} D^{-5/3}$	Eq. A.1
$D^{-2} \propto Q/P$	Effect of fan size on efficacy	S	Speed	$Q/P = S^{-2} D^{-2}$	Eq. A.3

First, we consider changes in fan performance as a result of changes in speed. As can be seen in Eq. A.1 and Eq. A.2, power consumption increases proportionally to the cube of speed ($S^3 \propto P$), and airflow is linearly related to speed ($S \propto Q$), assuming fan size remains constant. Accordingly, efficacy is proportional to the inverse square of speed ($S^{-2} \propto Q/P$) for a constant fan size, which is consistent with Eq. A.3. This indicates that we can expect significant decreases in efficacy as operating speed is increased, which has implications for policy design.

Next, we consider the changes in fan performance that result from increasing the size of a fan. For a constant airflow, an increase in size can significantly reduce power consumption ($D^{-4} \propto P$) and increase efficacy ($D^4 \propto Q/P$), in accordance with Eq. A.4 and Eq. A.5. Therefore efficacy and power consumption can be significantly improved as a result of increasing fan size.

$$P = Q^3 D^{-4} \quad \text{Eq. A.4}$$

$$Q/P = Q^{-2} D^4 \quad \text{Eq. A.5}$$

However, these improvements are accompanied by a reduction in speed ($D^{-3} \propto S$) according to Eq. A.2, which reduces thermal comfort as a result of the reduction in downward air speed. If we try to maintain a constant speed while increasing size, we see a drastic increase in power consumption ($D^5 \propto P$). Therefore thermal comfort resulting from downward air speed must be carefully considered when increasing blade length to improve efficacy and power consumption.

This is in accordance with Eq. A.6, which results from using Eq. A.1 Eq. A.1 to substitute for S in Eq. A.3. In this case the speed, and, in turn, the thermal comfort are not proportionally reduced ($D^{-5/3} \propto S$) to the same extent as the case in which constant airflow is assumed ($D^{-3} \propto S$). However, maintaining a constant speed while increasing fan size still reduces efficacy ($D^{-2} \propto Q/P$), in accordance with Eq. A.3. These issues highlight the tradeoff between improving airflow and efficacy as blade length is increased, versus increasing power consumption to ensure that speed and thermal comfort are satisfactory. Accordingly, the tradeoff has implications for policy design as discussed in Section 5.1

$$Q/P = P^{-2/3} D^{4/3} \quad \text{Eq. A.6}$$

Appendix B. Heat Transfer and Thermal Comfort

Eq. B. 1 and Eq. B.2 present the formula for the convective heat flux exchange between a human body and its surrounding environment, as described in (Djongyang et al. 2010).

$$C = h(T_a - T_{sk})AF \quad \text{Eq. B. 1}$$

$$h = \begin{cases} 3.5 + 5.2[v_a + 0.0052[M - 58]] & \text{if } v_a \leq 1 \text{ m/s} \\ 8.7[v_a + 0.0052[M - 58]]^{0.6} & \text{if } v_a > 1 \text{ m/s} \end{cases} \quad \text{Eq. B. 2}$$

Where:

C is the convective heat flux exchanged (W)

h is the convective heat-transfer coefficient ($\frac{W}{m^2K}$)

T_a is the ambient air temperature (K)

T_{sk} is the mean skin temperature (K)

A is the effective convection body area (m^2)

$F \in [0,1]$ is the clothing area factor, for which 0 represents high clothing insulation and 1 represents low insulation

v_{ar} is the resultant air velocity, taking into account the ambient air velocity (m/s)

v_a is the ambient air velocity (m/s)

$M \leq 200$ is the metabolic heat production (W/m^2)

We can take the derivative of Eq. B. 1 Eq. B. 1 with respect to v_a (dC/dv_a) to analyze the effects on heat flux exchange over the human body of downward air velocity from a ceiling fan. This can then be manipulated as shown in Eq. B.3 to derive the ratio of percent changes of v_a to C . From Eq. B.3 we can see that for a $v_a \leq 1 \text{ m/s}$, a change in v_a causes a proportionate change in convective heat flux C , as values for v_a increase. In contrast, for a $v_a > 1 \text{ m/s}$, an increasing v_a has a decreasing marginal effect on the change in C . Therefore, increasing fan speed beyond a certain point does not greatly improve thermal comfort, which is a function of C .

$$\frac{\% \Delta v_a}{\% \Delta C} \approx \frac{dC}{dv_a} \frac{v_a}{C} = \begin{cases} 5.2[T_a - T_{sk}]AFv_a/C & \text{if } v_a \leq 1 \text{ m/s} \\ 5.22[v_a + 0.0052[M - 58]]^{-0.4} [T_a - T_{sk}]AFv_a/C & \text{if } v_a > 1 \text{ m/s} \end{cases} \quad \text{Eq. B.3}$$

In this paper, we do not discuss precisely how thermal comfort relates to convective heat flux C because this can differ greatly from person to person and according to the type of activity in which a person is engaged (Djongyang et al. 2010). This issue is also represented by the person-specific and setting-specific variables, such as metabolic heat production, body area, skin

temperature, and clothing (M , T_{sk} , A , and F). The effectiveness of ceiling fans also depends on whether they are appropriately placed with respect to the location of occupants within rooms so that air movement near occupants' bodies is maximized. All these sources of uncertainty make a precise discussion of ancillary benefits for thermal comfort beyond the scope of this paper. This is likely to remain the most difficult benefit of cooling systems to quantify in the near future and suggests the need for further studies. However, since the *existence of such ancillary benefits is well established in the thermal comfort literature*, policymakers could design pilot programs to empirically quantify such benefits and maximize their impact in real-world settings.

Appendix C. Effect of Fan Speed on Efficacy

Efficacy has an inverse relationship with fan speed. We examine the relationship both empirically and theoretically in this appendix.

Empirical Relationship

A sample of 26 fans from 9 manufacturers from the Hunter Fan Company's test results used for development of the Energy Star program and first published in April 2001, is shown in the Figure 15 below (Davis Energy Group, 2004). It plots fan performance at each of the three operating speeds. Most of the fans have similarly shaped performance curves despite some being more efficient than others, but four fans had significantly poorer performance and a distinctly different curve. The efficacy curves for the poor performing fans are the ones with the negative slopes.

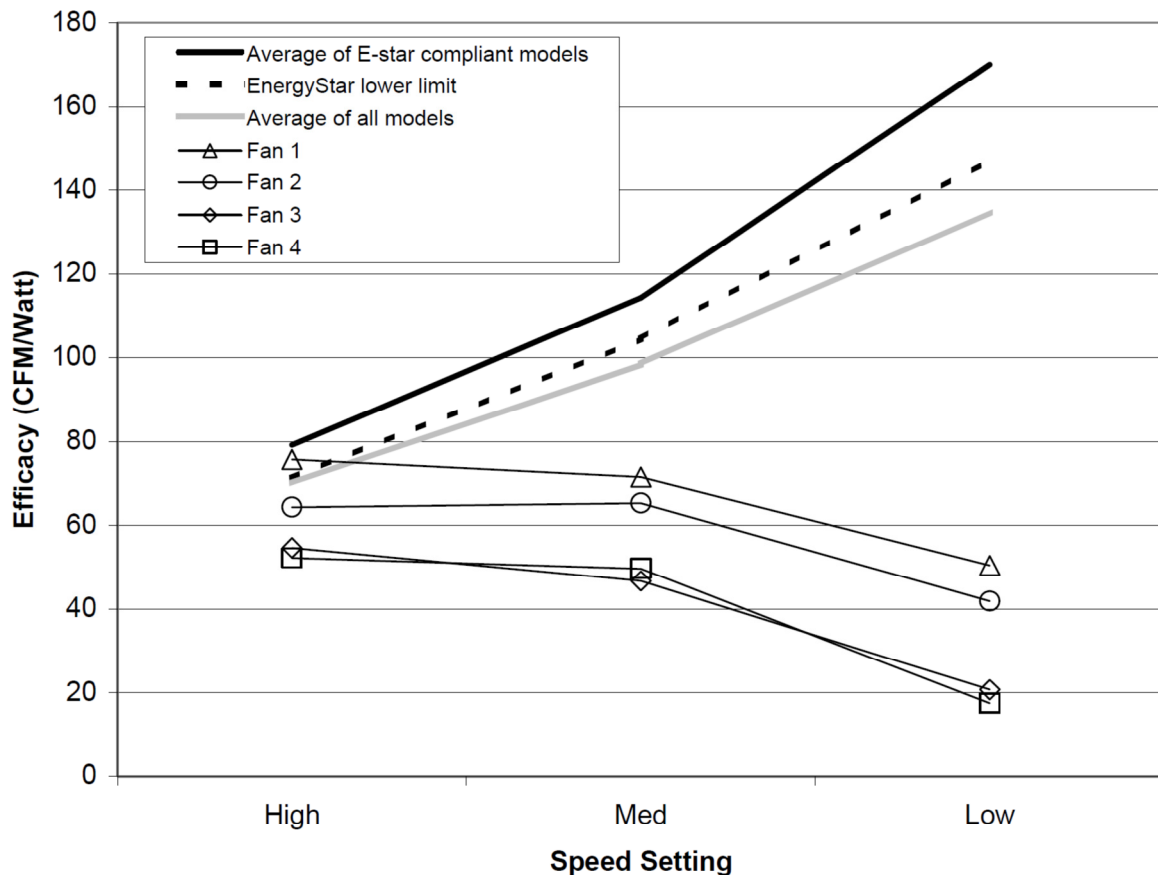

Source: Davis Energy Group, 2004

Figure 15 Efficacy Versus Fan Speed

A regression fit to the average of all models using the speed/airflow settings (high=5000 cubic feet per minute (cfm), medium=2500 cfm and low=1250 cfm) yields a fit as follows

$$\text{Efficacy} = -50.5 \ln(\text{airflow}) + 495.07$$

i.e. efficacy is inversely proportional to the logarithm of airflow(or speed, for constant size).

This indicates that decreases in efficacy as operating speed is increased are lower than that indicated by the similitude relationships discussed in Appendix A. i.e. that efficacy is proportional to the inverse square of speed ($S^{-2} \propto Q/P$) for a constant fan size. Note that these similitude relationships assumed constant motor efficiency, while the empirical results do not.

Efficacy reduces by 35 CFM/W for every doubling of speed. i.e. in doubling from 1250 cfm to 2500 cfm efficacy reduced from 135 CFM/W to 100 CFM/W(100% increase in speed leads to a 25.9% decrease in efficiency).

Theoretical Relationship

Carter (1960, 1961) suggested a relationship between efficiency (not efficacy) of fans and compressors and speed as:

$$1-\eta = k \text{Re}^n, n=-0.5 \text{ for } \text{Re}<5 \times 10^4$$

Where Re is the Reynolds Number $\text{Re} = \frac{\rho v D}{\mu}$, which governs the transition between laminar and turbulent flow and is linearly proportional to fan speed (v). This suggests that $1-\eta$ increases with the square root of speed, or that efficiency decreases with the square root of speed, as speed increases, for axial flow machines such as ceiling fans and compressors.

Bullock (1964) suggested a similar relationship as follows:

$$\frac{1-\eta_1}{1-\eta_2} = a + b \left(\frac{\text{Re}_1}{\text{Re}_2} \right)^c$$

Where Re is the Reynolds Number $\text{Re} = \frac{\rho v D}{\mu}$, which governs the transition between laminar and turbulent flow and is linearly proportional to fan speed (v), and

$$0 < a < 0.5,$$

$$0.5 < b < 1, \text{ and}$$

$$-0.2 < c < -0.1$$

This also suggests that $1-\eta$ increases with speed to a power between -0.2 and -0.1, or that efficiency decreases with speed to the power c(between -0.2 and -0.1), as speed increases, for axial flow machines such as ceiling fans and compressors.

All of the above data, suggest that efficiency decreases at a rate at most the square root of speed, as speed increases.

Appendix D. Cost of Conserved Electricity Results

Here we present the results of the cost effectiveness analysis for the economies of the SEAD participating governments and China, for the various efficiency improvement options. The assumptions regarding % savings and incremental costs are the same as those presented in chapter 2. This is a reasonable assumption as the % savings numbers are the same for the same technology regardless of economy, while the costs of BLDC motors and AC induction motors are driven mainly by materials costs and the costs of electronics, which are part of the global market. The cost estimates for efficient blades are more uncertain as these may be based on proprietary designs, and blade design and manufacture is also driven by aesthetic considerations, rather than just efficiency. This is also reflected in *divergent* estimates of the costs of manufacturing depending on the design, material, manufacturing, and treatment/finishing processes, as discussed in section 2.3.2.

Table 15 Cost of Conserved Electricity for various efficiency options in the SEAD economies and China

Economy	Discount Rate	Baseline UEC (kWh)	Efficient Blades (15% savings, \$3.5 incremental cost)		BLDC Motor (50% savings, \$10.5 incremental cost)		Improved AC induction motor (36% savings, \$1.5 incremental cost)		Representative Tariff (\$/kWh)
			CCEm (\$/kWh)	CCEc (\$/kWh)	CCEm (\$/kWh)	CCEc (\$/kWh)	CCEm (\$/kWh)	CCEc (\$/kWh)	
Australia	3.11%	21	\$0.13	\$0.26	\$0.12	\$0.24	\$0.023	\$0.047	\$0.10
Brazil	11.58%	88	\$0.05	\$0.09	\$0.04	\$0.08	\$0.008	\$0.016	\$0.19
Canada	1.90%	11	\$0.23	\$0.47	\$0.21	\$0.42	\$0.042	\$0.084	\$0.08
China	1.63%	75.3	\$0.03	\$0.07	\$0.03	\$0.06	\$0.006	\$0.012	\$0.19
EU	6.63%	11	\$0.30	\$0.59	\$0.27	\$0.53	\$0.053	\$0.106	\$0.19
India	7.60%	224	\$0.02	\$0.03	\$0.01	\$0.03	\$0.003	\$0.005	\$0.08
Indonesia	1.12%	150	\$0.02	\$0.03	\$0.01	\$0.03	\$0.003	\$0.006	\$0.09
Japan	3.28%	21	\$0.13	\$0.26	\$0.12	\$0.24	\$0.024	\$0.047	\$0.22
Korea	4.19%	21	\$0.14	\$0.28	\$0.12	\$0.25	\$0.025	\$0.049	\$0.07
Mexico	3.81%	88	\$0.03	\$0.06	\$0.03	\$0.06	\$0.006	\$0.012	\$0.08
Russia	3.67%	11	\$0.26	\$0.51	\$0.23	\$0.46	\$0.046	\$0.092	\$0.05
South Africa	3.33%	88	\$0.03	\$0.06	\$0.03	\$0.06	\$0.006	\$0.011	\$0.08
U.S	1.47%	78.1	\$0.03	\$0.06	\$0.03	\$0.06	\$0.006	\$0.012	\$0.11

Green highlights indicate the option is cost effective, in comparison with average tariffs.

As can be seen from the table, improved AC induction motors are cost effective in almost all economies, while BLDC motors and efficient blades are cost effective in countries with higher usage (i.e. high UECs), such as Brazil, China, India, Indonesia, Mexico, South Africa and the US.