

J of the IES, 26 (No. 1) Winter 1997

A Comparative Candlepower Distribution Analysis for Compact Fluorescent Table Lamp Systems

Erik Page, Chad Praul, and Michael Siminovitch

Lighting Systems Research Group
Building Technologies Program
Energy and Environment Division
Ernest Orlando Lawrence Berkeley Laboratory
University of California
1 Cyclotron Road
Berkeley, California 94720

July 1995

This work was supported by the Assistant Secretary for Energy Efficiency and Renewable Energy, Office of Building Technologies, Building Equipment Division of the U.S. Department of Energy under Contract No. DE-AC03-76SF00098.

A Comparative Candlepower Distribution Analysis for Compact Fluorescent Table Lamp Systems

Erik Page, Chad Praul, and Michael Siminovitch

Lighting Systems Research Group
Lawrence Berkeley Laboratory
Berkeley, CA 94720

Abstract

The residential lighting sector represents a significant opportunity for energy conservation due to the almost exclusive use of inefficient incandescent sources. Compact fluorescent lamps (CFLs) have the potential to transform this market by using one fourth as much power as an incandescent to provide the same amount of light. While technical advances such as triphosphors and electronic ballasts have addressed issues of color rendition, flicker, and hum, CFLs still face significant market barriers, particularly their 'perceived brightness' level in traditional fixture applications. When operated in fixtures originally designed for A-lamps, CFLs with equal total lumen packages can appear dimmer due to differences in their light distributions. One such fixture, the common table lamp, is typically operated for more than 3 hours a day, and thus represents a significant opportunity for energy savings. LBL conducted a series of goniophotometric candela distribution studies of table lamps with the initial objective of matching with CFLs the light distribution of the consumer accepted A-lamp. While goniometric testing was done on numerous CFL and incandescent sources, this paper focuses on three typical sources which have very different distributions. Our photometric studies indicate that horizontally oriented CFLs may produce a more desirable distribution than either A-lamps or vertically oriented CFLs by minimizing shade losses and thus maximizing the amount of useful light leaving the fixture. Optimizing fixture geometry and lamp position can significantly increase the efficiency of these CFL fixtures. Ongoing research with the fixture industry seeks to identify and develop efficient source/fixture configurations.

Introduction

In 1994, the 96 million households in the United States used an average of 1,500 kWh of electricity for lighting. Thus, residential lighting accounts for around 145 billion kWh per year. Illumination in the home is provided almost exclusively by incandescent sources with efficacies of approximately 15 lumens per watt. Replacing these sources with 60-70 lumen-per-watt compact fluorescent systems would create very significant energy savings. The average compact fluorescent lamp can reduce the energy consumption in a traditional incandescent application by approximately 75%.¹

Recent studies indicate that 70% of residential lighting energy is consumed by just 30% of a typical home's fixtures, called 'high-use' sockets.² A significant portion of these high-use sockets are table or floor lamps and could be replaced with either CFL retrofits or 'dedicated' CFL fixtures.³ But replacing an incandescent A-lamp with a CFL changes the fixture's optical distribution, potentially reducing perceived brightness and adding to consumer dissatisfaction. In order to characterize the differences in candlepower distribution associated with different sources, a series of photometric studies were conducted using a swing-arm goniophotometer. Computer controlled tests generated standard photometric reports with candela plots, zonal lumen summaries, and total lumen output. These results were then compiled into a comprehensive database of goniometric reports that provide basic information as to how different sources perform within typical shaded table lamp systems. The information from these studies will aid in the development of high-efficiency 'dedicated fixtures' that use CFLs as the source.

Initial goniometric studies focused on how well retrofit screw base CFLs work with shaded lamps. Since the sides of a CFL's tubes produce most of its light, we theorized that the lamp shade

absorbs much of the light when the lamps are placed in the traditional vertical, or base-down, orientation. These losses are compounded by the 10-20% decrease in light output CFLs experience while operating in the base-down orientation.⁴ In addition, vertical CFLs direct less light out of the top of the fixture than incandescents, which have a more isotropic light distribution. These basic lamp differences create fundamental differences in the appearance of the luminaires. Consumers are used to a bright halo of light emanating from the top aperture of the shade and bright illumination directly below the shade for high-definition tasks, such as reading. This potential mismatch between the CFL's intensity distribution and consumer demands creates a need for quantitative characterization of the problem and opens a window for new fixture designs.

Experimental Procedure

We developed a standard test protocol that used a swing-arm goniophotometer to study the distribution differences associated with typical CFL retrofits for table lamp applications. First, a standard, commonly available table lamp (black, reflectance = 4.4%, total height = 24", socket height = 17", cutoff angle = 18°) with a conical shade (white, reflectance = 51.9%, height = 12", minor diameter = 9", major diameter = 18", shade angle = 20°) was selected as the base fixture in which to compare the different sources. To isolate the differences between the sources, we used a fairly reflective, diffuse shade and low reflectance base to minimize fixture effects on the intensity distribution. A broad range of screw base CFL sources were then identified that would fit into the table lamp application. Each of these CFL sources was operated in position for approximately 100 hours to season the new lamp and establish a stable cold spot.

The table lamp fixture was first positioned within the goniometer and operated with a standard incandescent lamp, as shown in Figure 1. All lamp measurements were conducted using a stabilized line voltage of 120 volts. Photometric measurements consisted of a complete goniometric summary of candlepower over a full range of angles. We then repeated the measurements for the range of screw-base CFL retrofits.

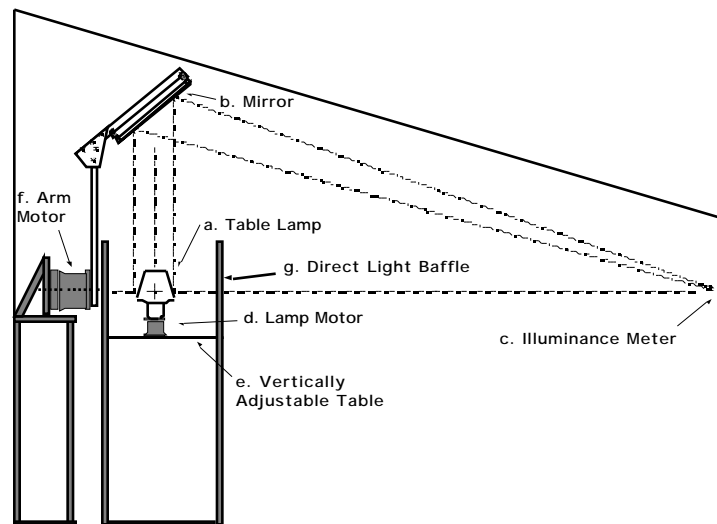

Figure 1: A Schematic of the Goniophotometer.

Candlepower distributions, zonal lumens, and fixture efficiencies were then summarized for each source. This information was compiled into a database and graphed for comparison. This paper provides sample results for three systems: a 100 W A-lamp, a 23 W triple-tube CFL and a 22 W Circline fluorescent lamp. It should be noted that power measurements indicated that the A-lamp,

triple tube and Circline were actually operating at 103.2 W, 19.0 W, and 22.8 W, respectively when regulated at 120 V.

Results

The candlepower plots shown in Figures 2a-c are for the table lamp operating without the shade and using a 100W A-lamp, a 23W triple tube, and a 22W Circline. These figures illustrate how different lamp sources can yield widely varied distributions. The plots indicate one sweep of the goniometer's arm around the lamp and map out the candlepower distribution in a single vertical plane. Nadir is shown as 0° on the plot and corresponds to readings directly under the lamp, while zenith occurs at 180° and represents readings directly above the fixture.

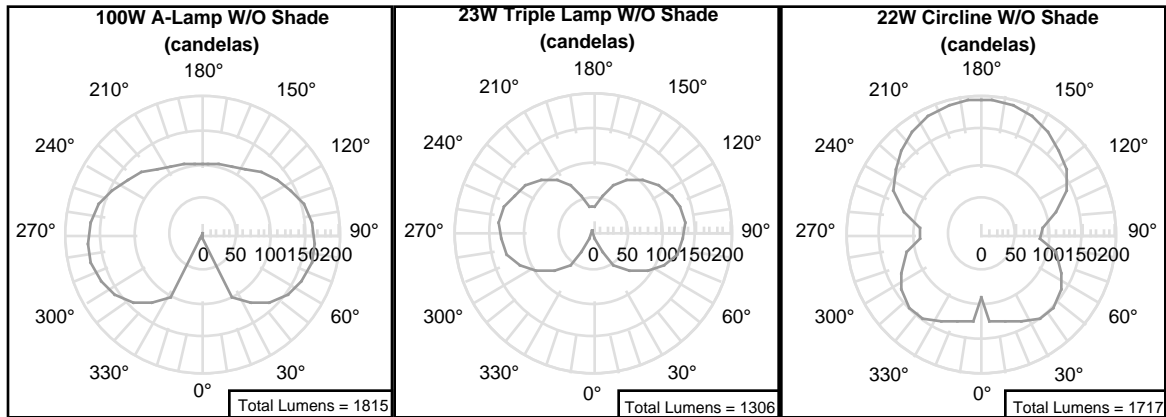

Figures 2a-c: Candela Plots of Table Lamps Operating without Shades.

Figure 2a shows the fairly symmetric intensity distribution of the 100 W A-lamp. The intensity varies between 100 and 170 candelas, except for where the fixture base blocks the flux at near-nadir angles of $<20^\circ$. The variations from perfect symmetry arise from the linear orientation of the tungsten filament and lamp elongation, but the lamp geometry and frosting holds these variations to a minimum.

Figure 2b shows the intensity distribution of the 23 W triple-tube lamp. The triple lamp is most intense (with over 130 candelas) at 90° because of its predominately vertical illuminating surfaces. The intensity drops to less than 40 candelas near zenith angles because the lamp's projected area is relatively small there. Similarly, the intensity diminishes near nadir until the fixture's base is again encountered, blocking all flux.

Figure 2c illustrates the unique distribution of the 22 W Circline lamp. The Circline lamp distributes the majority of its flux vertically due to a predominance of horizontal illuminating surfaces. Its intensity ranges from more than 190 candelas at zenith to a minimum of 90 candelas at 90° . Additionally, since the lamp extends out beyond the fixture base, over 90 candelas are found at nadir.

A comparison of the A-lamp and the Circline lamp demonstrates the advantages of focusing output vertically. While the A-lamp yields the largest total lumen package of 1815 lumens, the Circline has a much more intense output at the crucial nadir and zenith angles. In effect, fewer total lumens are required to produce sufficient illumination where it is actually needed: at nadir for task lighting and zenith for indirect lighting.

Figures 3a-c show how these light distributions are affected by the addition of the white, fluted lamp shade.

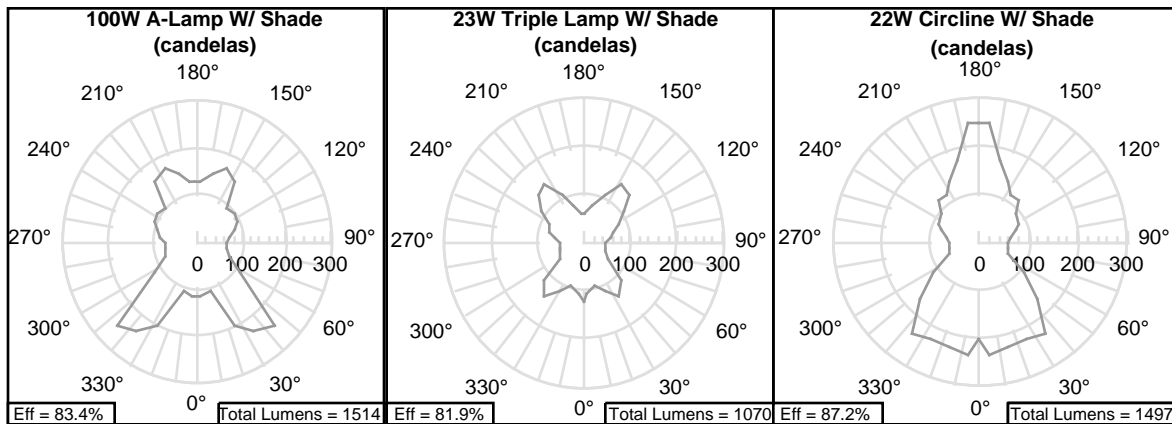

Figures 3a-c: Candela Plots of Table Lamps Operating with Shades.

Figure 3a shows how intensity distribution of the 100 W A-lamp operating in a shaded table lamp varies from a low of less than 70 candelas near 90° to a high of over 250 candelas at around 45°. The shade blocks flux in the 50°-140° range and redirects it into the 0°-50° and 140°-180° zones. This has the effect of blocking potential glare and redirecting flux to areas where it can be used for indirect (140°-180°) or task (0°-50°) lighting. Shade-reflected light now boosts the intensity at nadir to 120 candelas.

Similar shade effects are found in Figure 3b for the 23 W triple tube. At 90°, the intensity drops to 50 candelas, with peaks of 150 candelas around 45° and 145°. Again, reflected light has increased nadir intensity, yielding values of around 130 candelas.

Figure 3c indicates that the Circline lamp produces over 240 candelas near nadir and zenith, while an intensity minimum of 60 candelas is found at 90°. These high intensity values at nadir and zenith result from the superposition of direct illumination with shade reflections.

The shade losses are also illustrated by the change in total lumens outputted by the luminaire. Table 1 shows the lumen totals of the six data runs described above broken down into three zones: below the shade (0°-50°), at the shade (50°-140°), and above the shade (140°-180°). Table 2 represents this same data as a percentage of the *total unshaded* lumens for each lamp. The unshaded data from both Table 1 and Table 2 indicate that the A-lamp and the triple lamp direct significantly more flux into the shade than the Circline lamp. While the addition of the shade moves much of the flux into the non-shaded zones, the Circline lamp still produces a greater percentage of its total luminous flux in these zones than the other two lamps. The shade actually has the effect of decreasing the lumens above the shade in the Circline table lamp fixture because it blocks some of the direct flux.

Since shade absorption is inversely proportional to fixture efficiency, we would expect that the more flux a lamp sends into the shade zone, the less total flux leaves the fixture. This can be seen in the results in Table 2. The triple lamp transmits the most flux (82.6%) into the shade zone, followed by the A-lamp (77.1%), and finally by the Circline lamp (64.1%). Consequently, the Circline lamp retains 87.2% of its total light output when the shade is added, while the A-lamp drops to 83.4%, and the triple lamp falls to 81.9%. These shade losses, combined with the distributional issues discussed above, further indicate the advantages of horizontally oriented sources.

Table 1: **Lumen Totals** by Zone for Various Unshaded and Shaded Lamps

	100W A-Lamp	23W Triple	22W Circular
UNSHADED			
Below Shade	253.8	119.2	350.0
At Shade	1399.0	1078.2	1100.0
Above Shade	162.5	108.8	266.6
TOTAL	1815.3	1306.2	1716.6
SHADED			
Below Shade	489.6	276.9	551.4
At Shade	795.6	630.9	735.6
Above Shade	229.0	161.7	210.0
TOTAL	1514.2	1069.5	1497.0

Table 2: **Lumen Percentages** by Zone for Various Unshaded and Shaded Lamps

	100W A-Lamp	23W Triple	22W Circular
UNSHADED			
Below Shade	14.0%	9.1%	20.4%
At Shade	77.1%	82.6%	64.1%
Above Shade	8.9%	8.3%	15.5%
TOTAL	100.0%	100.0%	100.0%
SHADED			
Below Shade	27.0%	21.2%	32.1%
At Shade	43.8%	48.3%	42.9%
Above Shade	12.6%	12.4%	12.2%
TOTAL	83.4%	81.9%	87.2%

These shade effects are further illustrated by the differences between Figure 4, which shows zonal lumen percentages *without* the shade, and Figure 5, which shows the zonal lumen percentages *with* the shade.

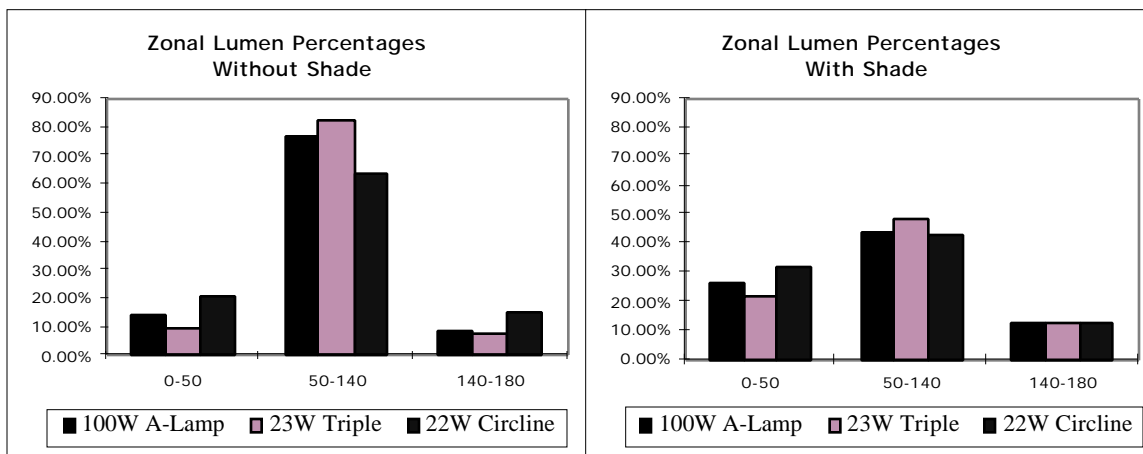

Figure 4: Zonal Lumens Without Shade

Figure 5: Zonal Lumens With Shade

Conclusions

Goniometric studies show that significant differences in light distribution can occur when CFL retrofits are made in table lamps originally designed for A-lamps. Lamp position and geometry can have a significant effect on the light output, light distribution, and shade losses, and thus fixture efficiencies. Data suggests that a predominately horizontally oriented source (in this case a Circline) outperforms both a symmetric (A-lamp) and a predominately vertically oriented source (triple lamp) in table lamp fixtures. Thus, the Circline lamp proves to be more efficient than the A-lamp not only because of the inherent advantage in fluorescent vs. incandescent lighting, but also because of its distributional characteristics. This horizontally oriented lamp concentrates its flux in the critical nadir and zenith areas and does not suffer traditional CFL thermal losses from operating base-down. The Circline is particularly well-suited for table lamp applications using the geometric differences from the A-lamp as an additional benefit. While many household fixtures will not accommodate Circline retrofits due to the significant size/shape variations from A-lamps, most table lamp fixtures can readily accept Circline lamps. Ongoing studies with the fixture manufacturing industry continue to develop new fixture designs that optimize vertical CFLs. By tilting the lamps or changing the shade geometry and reflectance, it may be possible to fully utilize the unique candela distribution of vertical CFLs as well.

Acknowledgment

This work was supported by the Assistant Secretary for Energy Efficiency and Renewable Energy, Office of Building Technologies, Building Equipment Division of the U.S. Department of Energy under Contract No. DE-AC03-76SF00098.

References

- 1 Siminovitch, Michael and Mills, Evan. 1995. Dedicated CFL Fixtures for Residential Lighting. *LD+A* March 1995:28-32.
- 2 Hanford, J.W. et. al. 1994. *Baseline Data for the Residential Sector and Development of a Residential Forecasting Database*. Berkeley, CA: Lawrence Berkeley Laboratory.
- 3 Ji, Yunfen and Davis, Robert. 1993. Application Testing of Compact Fluorescent Lamps: Table Lamps and Recessed Downlights. Presented at 1993 IESNA conference.
- 4 Siminovitch, M., Pankonin, E., Praul, C. and Zhang, C. 1994. Improving the Performance of Integral Screw-Base Compact Fluorescent Lamps in a Base-Down Burning Position Using Thermal Bridge Systems. *J. IES* 24(no.1):94-99.