



Lawrence Berkeley Laboratory

UNIVERSITY OF CALIFORNIA

ENERGY & ENVIRONMENT DIVISION

A Carbon Monoxide Passive Sampler: Research and Development Needs

G.W. Traynor, M.G. Apte, R.C. Diamond, and A.L. Woods

November 1991

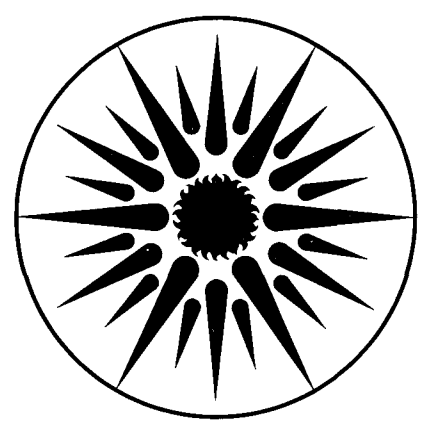

ENERGY & ENVIRONMENT
DIVISION

LOAN COPY 1
Circulates 1
for 4 weeks
Bldg. 50 Library.
Copy 2
LBL-26880

DISCLAIMER

This document was prepared as an account of work sponsored by the United States Government. While this document is believed to contain correct information, neither the United States Government nor any agency thereof, nor the Regents of the University of California, nor any of their employees, makes any warranty, express or implied, or assumes any legal responsibility for the accuracy, completeness, or usefulness of any information, apparatus, product, or process disclosed, or represents that its use would not infringe privately owned rights. Reference herein to any specific commercial product, process, or service by its trade name, trademark, manufacturer, or otherwise, does not necessarily constitute or imply its endorsement, recommendation, or favoring by the United States Government or any agency thereof, or the Regents of the University of California. The views and opinions of authors expressed herein do not necessarily state or reflect those of the United States Government or any agency thereof or the Regents of the University of California.

**A CARBON MONOXIDE PASSIVE SAMPLER:
RESEARCH AND DEVELOPMENT NEEDS**

by

Gregory W. Traynor, Michael G. Apte,
Richard C. Diamond, and Alicia L. Woods

Indoor Environment Program
Energy & Environment Division
Lawrence Berkeley Laboratory
1 Cyclotron Road
Berkeley, CA 94720

November, 1991

This work was supported by the Pacific Gas and Electric Company, San Ramon, California, under Contract No. Z19-5-298-87A through the U.S. Department of Energy under Contract No DE-AC03-76SF00098.

TABLE OF CONTENTS

ABSTRACT	i
INTRODUCTION	1
REVIEW OF CO SAMPLING TECHNIQUES	5
ECONOMIC COMPARISONS OF CO SAMPLING TECHNIQUES FOR A HYPOTHETICAL LARGE-SCALE INDOOR AIR QUALITY FIELD STUDY	16
STATUS OF THE LBL REFLECTIVE CO PASSIVE SAMPLER	19
CONCLUSIONS AND RECOMMENDATIONS	23
ACKNOWLEDGEMENTS	24
REFERENCES	25
Tables	29
Figures	32

ABSTRACT

In rare instances, carbon monoxide (CO) levels in houses can reach dangerously high concentrations, causing adverse health effects ranging from mild headaches to, under extreme conditions, death. Hundreds of fatal accidental carbon monoxide poisonings occur each year primarily due to the indoor operation of motor vehicles, the indoor use of charcoal for cooking, the operation of malfunctioning vented and unvented combustion appliances, and the misuse of combustion appliances. Because there is a lack of simple, inexpensive, and accurate field sampling instrumentation, it is difficult for gas utilities and researchers to conduct field research studies designed to quantify the concentrations of CO in residences. Determining the concentration of CO in residences is the first step towards identifying the high risk appliances and high-CO environments which pose health risks. Thus, there exists an urgent need to develop and field-validate a CO-quantifying technique suitable for affordable field research. A CO passive sampler, if developed, could fulfill these requirements. Existing CO monitoring techniques are discussed as well as three potential CO-detection methods for use in a CO passive sampler. Laboratory and field research needed for the development and validation of an effective and cost-efficient CO passive sampler are also discussed.

INTRODUCTION

There are five major categories of indoor pollution that have been identified as potential health threats to building occupants. These categories are (1) combustion pollutants (including some organic compounds) from a variety of sources including smoking, attached garages, and unvented or partially vented combustion appliances; (2) radon, primarily from the soil surrounding a residence; (3) organic compounds from building materials and consumer products (e.g., formaldehyde, solvents); (4) biological contaminants (e.g., microorganisms, molds, pet dander); and (5) remnants from past building practices (e.g., asbestos, lead).

One important indoor combustion pollutant is carbon monoxide (CO). Carbon monoxide is a colorless, odorless gas that is generated during the incomplete combustion of organic material such as natural gas, propane, kerosene, wood, gasoline, and tobacco. Exposure to high concentrations of CO can cause a wide variety of adverse health effects, including, under extreme conditions, death. Although a large proportion of CO deaths are caused by fire and internal combustion engine accidents, CO is of particular interest to gas utilities because of the potential danger of poisoning it poses to their customers when malfunctioning appliances cause indoor CO concentrations to increase. CO and other products of combustion can be injected into the indoor environment either directly, as with the use of unvented appliances, or through the leaking or backdrafting of a venting system. Indoor sources of CO include unvented kerosene and gas space heaters; malfunctioning vented gas, oil, coal and wood space heating systems; wood fireplaces; indoor unvented charcoal cooking; and attached garages where automobiles or gas motors are operated.

Each year in the United States, an estimated 10,000 persons seek medical attention or lose at least one day of normal activity because of carbon monoxide intoxication. In addition, 1500 people die from accidental exposure to high concentrations of CO, making carbon monoxide the leading cause of death from poisoning in the United States (USDHHS, 1982; USDHHS, 1986). An estimated 1000 deaths and 5000 injuries are caused each year by CO emissions from improperly used, constructed, installed, or maintained space heating devices (Marsh, 1982; Novick, 1972). Approximately 500 nonvehicular, nonsuicide CO deaths are documented each year by the National Center For Health Statistics, using death certificate information (Cobb and Etzel, 1991). The source of CO was identified for approximately one half of these deaths, revealing that 49% were caused by coal, kerosene or wood appliances, 43% by some type of gas (e.g., natural gas, liquid petroleum gas) appliances, and 8% by an industrial process.

In individuals exposed to the gas, carbon monoxide is absorbed into the bloodstream through respiration, creating carboxyhemoglobin (COHb). Chronic exposure to carbon monoxide leading to COHb levels of approximately 2% to 20% of total hemoglobin can cause mild to severe health effects. Deleterious effects on cardiovascular performance have been seen in individuals exposed to low levels of CO exposure. COHb levels of 2.9% to 4.5% have been shown to aggravate the symptoms of chronic angina patients, who are thought to be the population most sensitive to CO (Ekblom and Huot, 1972; USEPA, 1984; Kleinman and Whittenberger, 1985). Research has shown that COHb levels from 2 to 5% can affect vision functions, time perception, performance of some psychomotor tasks, and the ability to detect small unpredictable environmental changes (vigilance) (Bartlett, 1968; NRC, 1981; McFarland, 1973). Other sensitive groups include pregnant women, fetuses, infants, the elderly, people living at high altitude, people suffering from anemia, people with obstructive pulmonary disease, and people with coronary artery disease (CARB, 1982; Shephard, 1983; Longo, 1977; Lambert and Samet, 1988; Atkins and Baker, 1985).

Cases of both chronic and acute CO poisoning are often misdiagnosed because the symptoms are similar to those of a number of other common conditions such as flu and food poisoning (Barret *et al.*, 1985; Caplan *et al.*, 1986; Dolan *et al.*, 1987; Fisher and Rubin, 1982; Johnson *et al.*, 1975; Kelley and Sophocleus, 1978). Thus, despite the estimations stated above, it is likely that the number of cases of both chronic and acute CO poisonings, as well as those leading to death, are currently underestimated.

The United States Environmental Protection Agency (EPA) has set up a number of guidelines in response to concern about CO poisoning. In its 1984 Addendum to the 1979 EPA Criteria Document for Carbon Monoxide, the EPA states in a summary of cardiovascular effects that, "... following a review of the peer reviewed scientific literature ..., the critical effects level for NAAQS [National Ambient Air Quality Standards] setting purposes is approximately 3% COHb (not including a margin of safety)." A 3% COHb level can be achieved by inhaling 25 ppm of carbon monoxide in room air for 8 hours while sedentary. While there is no indoor CO standard, the EPA has set standards for outdoor CO at "9 ppm, 8-hour average or 35 ppm, 1-hour average, neither to be exceeded more than once a year" (USEPA, 1984). In California, the 8-hour standard is 9 ppm (except in the Lake Tahoe Air Basin, where it is 6 ppm due to altitude related effects) while the 1-hour standard is 20 ppm (CARB, 1982).

Several indoor air quality (IAQ) studies have shown that concentrations of carbon monoxide in houses often exceed the EPA standards (Akland *et al.*, 1985; Radford, 1973; McFee, 1970; Rench, 1976; Lao *et al.*, 1982). A non-random national study of 1,820 houses showed 17% had

carbon monoxide levels above 10 ppm in at least one area of the house (Schaplowsky *et al.*, 1974). This study also noted that "improper or lack of venting, lack of maintenance, and defective appliances were the principal causes of high CO production." Thus, in the U.S., there exists a potential CO-poisoning health risk to the occupants of houses with malfunctioning appliances.

A field research study is necessary to evaluate the magnitude of this health risk, since its extent is yet undetermined. More specifically, houses with elevated CO concentrations must be identified and the specific sources of CO investigated so that these elevated concentrations may be mitigated. Such research would require the monitoring of CO levels in a statistically significant subset of houses with potential indoor CO sources in order to identify those houses with elevated levels. Once the houses are identified, follow-up visits could determine the specific CO source(s). As more houses are screened, a database of housing and source characteristics could be developed to aid in the identification of high-risk houses and sources. Unfortunately, this type of field research is extremely expensive because of the lack of inexpensive instrumentation to quantify indoor and outdoor CO concentrations.

Currently, no simple, inexpensive, and accurate method has been developed to survey indoor concentrations of CO. A CO passive sampler, if available, would be an appropriate screening and research tool for identifying houses with elevated CO levels. Such a sampler could be distributed through the mail, as was done by Sexton *et al.* (1986) for measuring formaldehyde in residences. In addition, a field study similar to Sexton's would be possible with a CO passive sampler. Furthermore, such a passive sampler would make the routine, inexpensive monitoring of CO in gas customers' houses a possibility.

Two conferences addressing the potential of passive samplers for studies of gas-phase pollutants indicate the significance of this topic (ACGIH, 1980; USEPA, 1974). The importance of developing such instrumentation arises, in part, from the realization that real-time area monitors are not appropriate for large-scale field studies of indoor environments. Most area monitors are sophisticated instruments that require a trained technician to operate and maintain. In addition, they are often quite sensitive to rough treatment, require careful calibration and operation in the field, require a separate data logging system, and are expensive. Because passive samplers do not require pumps or sensitive electronic components, they would not have many of the problems associated with real-time monitors. An ideal passive sampler would have the following characteristics:

1. lightweight and small
2. simple to operate
3. rugged
4. accurate and precise to within 10-20%
5. of sufficient capacity for sampling intervals of interest
6. long shelf-life before and after deployment
7. inexpensive

Given these characteristics, a passive sampler would make it possible for gas utilities, health departments, and researchers to conduct a variety of studies that cannot be accomplished with sophisticated electronic instruments because of their cost, their intrusion into the monitored area, and the extensive field support required for their utilization.

The remainder of this report reviews state-of-the-art carbon monoxide monitoring and sampling methods, both those in existence and those still under development. Following this review will be an economic comparison of conducting a hypothetical indoor CO field study using three different measurement strategies. In addition, progress-to-date and research needs associated with the development of a partially-realized passive sampler, the LBL reflective CO passive sampler, will be discussed.

REVIEW OF CO SAMPLING TECHNIQUES

Air pollutant sampling techniques suitable for IAQ studies can be divided into two rough categories, *active* or *passive*, based upon their principles of operation. Requirements of both active and passive samplers are (1) that they yield quantitative data on the pollutant of interest with accuracy and precision suitable for their application, (2) that their responses are stable (i.e., insignificant drift) in the environment in which they are to be used, and (3) that they are not significantly affected by interferences from other chemical species present.

Active systems mechanically sample the environment using pumps, and may use electronic detectors to monitor concentrations. These systems usually require training to operate as well as frequent calibration. They also tend to be large and sometimes quite noisy. Real-time infrared CO analyzers and electrochemical CO analyzers are examples of fully-contained active CO monitors. There are other active systems available, such as integrating bag collectors, which are not as cumbersome as these fully-contained active systems. An integrating bag collector operates by slowly filling an empty bag with the air to be sampled. Bags are usually filled by a peristaltic pump. The gas sample collected in the bag is subsequently analyzed using a real-time monitor.

Passive samplers do not require a power source during sampling. They can rely solely on molecular diffusion for sample collection, or can sample using pressure driven flow -- provided no external power supply is required during sampling. As outlined earlier, effective passive samplers, ones that can be used in large indoor air pollution field surveys, need to be reliable, cost-effective, small and unobtrusive, and capable of being deployed with simple instructions. A diffusion tube sampler such as the Palmes tube for NO₂ (Palmes *et al.*, 1976) is an example of such a passive sampler. Another example of a passive sampler is a pre-evacuated canister, which operates by slowly filling the canister with the air to be sampled. The canister is filled using its own vacuum coupled with an orifice flow control system. The gas sample collected by the canister is subsequently analyzed using a real-time monitor. Compared to a diffusion tube sampler, the canister sampler is large, obtrusive, and more complicated to deploy.

Two different types of gas monitoring methods are used with the air pollutant sampling techniques mentioned above, real-time methods or integrating methods. A real-time method continuously measures the concentration of the gas species of interest. An integrating method cannot continuously measure the gas species concentration, but rather continuously collects/samples the air to provide a time-weighted-average measurement of the gas concentration. There are two general integrating methods. The first method (e.g., diffusion

tube sampler, badge detector) uses a gas-specific detector placed in an environment. When exposed to the environment, the detector's response to the gas is proportional to the time the detector is exposed and to the gas concentration level. The other method (e.g., integrating bag collector, evacuated canister) uses a collector to sample the air.

Table 1 summarizes real-time and integrating techniques for detecting CO concentrations. The main advantage of real-time CO instrumentation, compared with integrating monitors, is that the former supplies a continuous concentration profile that allows for the identification of short-term peak concentrations. This profile can be obtained over the entire sampling period. Some real-time analyzers also measure concentrations over a very wide range of values with a high degree of accuracy and precision. However, for most IAQ field surveys, the increased accuracy provided by these analyzers is not needed and the measurements given by integrating monitors are often adequate. Despite the fact that short-term concentration information is lost with the use of integrating monitors, the average CO concentration yielded by these monitors is a sufficient indicator of dangerous indoor CO concentrations. Where a high average indoor CO concentration is measured, it is either due to a sustained high indoor CO concentration or very high CO peak concentrations; both scenarios are a health concern. If the pollutant source usage profile (i.e., the source on/off pattern) is known, then the real-time concentration profile can be mathematically modeled from the average CO concentration, the source usage profile, the house air-exchange rate, and the house volume.

As is further explicated below, each CO-sampling technique has potential advantages and disadvantages associated with it, depending on the data collection requirements of a particular study. Research design and selection of instrumentation to be used in IAQ field surveys must be based on such data collection requirements. Only the goal of the study will determine what these specific requirements are.

Available Methods for Determination of CO in Air

A detailed description of the currently available measurement techniques for CO are discussed below. Some information in this section has been obtained from Beatty, 1955; Slusher, 1966; LBL, 1976; and Girman, Traynor, and Hollowell, 1982. At present, only real-time CO monitors and integrating bag/canister collectors are available for use in IAQ field surveys. Although there are some CO passive samplers under development, none of the existing CO passive samplers at present fully meets the requirements for conducting large-scale surveys. Table 1 compares the different CO measurement technologies available for use in IAQ surveys.

Real-time (Active) Analyzers. The most widely-used methods for real-time monitoring of CO concentrations are (1) the electrochemical method and (2) non-dispersive infrared (NDIR) methods. The U.S. Environmental Protection Agency has adopted two specific NDIR methods (the double-beam method and the gas-filter-correlation method) as its reference methods for monitoring outdoor CO concentrations (USFR, 1971; USFR, 1975). NDIR methods are more popular than the electrochemical method because of their designation as EPA reference methods; however, the electrochemical method is less expensive. Most real-time methods for monitoring CO use active pumps to bring the sampled air to the detection system.

CO analyzers using the electrochemical technique consist of a cell that measures the current induced by the electrochemical oxidation of CO at a sensing electrode. Electrochemical cell analyzers, introduced commercially about 1970, avoid the wet chemistry (e.g., reagent handling, etc.) of the traditional colorimetric and amperometric analyzers by using a sealed module, the electrochemical cell, inside which all chemical reactions occur. CO diffuses through a semi-permeable membrane into the cell with the rate of diffusion being proportional to the CO concentration. At the sensing electrode, the CO undergoes electrochemical oxidation which produces electrons. This oxidation creates a lower potential in the sensing electrode compared with the counter-electrode, causing an electron current to flow. This current is proportional to the sample CO concentration. Sampling can be either active (i.e., using a pump) or diffusive depending on the design of the instrument. There are several combustion-generated pollutants that interfere (positively) with the electrochemical cell and thus a pre-filter (supplied by the manufacturer) is often needed to eliminate this effect. Specifications for electrochemical CO monitors vary among models and manufacturers. Typical specifications for electrochemical analyzers are: ranges of 0-2000 ppm down to 0-50 ppm, accuracy and precision of $\pm 1-3\%$ of full scale, minimum sensitivity of 0.5 ppm, response time of 60 seconds to 90% of concentration, and weight ranging from 0.25 kg to 4 kg.

NDIR methods utilize the infrared-absorbing capabilities of CO. CO absorbs infrared radiation in the wavelength range of 4.67 μm to 4.72 μm (Pierson, 1956). An NDIR analyzer using a double-beam arrangement is shown schematically in Figure 1. In this analyzer, infrared radiation from the filaments is directed onto two cells. One cell is a reference cell filled with a non-infrared absorbing gas, such as nitrogen or argon. The other is a sample cell through which the sampled air containing the gas of interest is continuously drawn. The detector seen in Figure 1 consists of two gas-impermeable chambers with a flexible metal diaphragm as a partition between the chambers. Both detector chambers are filled with the gas of interest, in this case, CO. The infrared radiation which passes through the reference cell enters one chamber of the detector, while the radiation passing through the sample cell enters the other

chamber. The gas in each chamber is heated by the incoming energy, thus causing a pressure increase in the two chambers. The rise in pressure is greater in the chamber receiving radiation from the reference cell, since a portion of the radiation transmitted through the sample cell has been absorbed by the gas of interest before entering the chamber on the sample cell side. This difference in pressure causes a diaphragm displacement, which is electronically measured as a capacitance change. The infrared radiation is chopped by an optical chopper to cause a periodic capacitance change, which modulates a radio-frequency signal from an oscillator. This signal is subsequently demodulated, amplified, and the output signal is continuously fed to a meter or a data recording device. The amplitude of the output signal is proportional to the concentration of CO. Typical specifications for double-beam NDIR analyzers are: ranges of 0-1000 ppm down to 0-50 ppm, accuracy and precision of less than $\pm 1\%$ full scale, minimum sensitivity of 0.5 ppm, linearity of $\pm 0.5\%$ full scale, variable response times of 1-16 seconds to 90% of concentration, and weight of approximately 30 kg.

A second NDIR analyzer uses the gas-filter-correlation method and is generally considered more suitable for air monitoring than the double-beam NDIR method because of its overall improved performance and reliability. In this method (see Figure 2), infrared radiation is passed through a rotating chopper and then a rotating gas filter which alternates between CO and N₂. The infrared beam then passes through a narrow bandpass filter and into a sample-cell, where it makes multiple passes before exiting onto to a solid-state infrared detector. As the CO side of the gas filter wheel rotates across the infrared beam, it produces a reference pulse which is not affected by the CO in the sample chamber. Since N₂ is transparent to infrared radiation, the N₂ side of the filter wheel produces a measure pulse which can be absorbed by CO. This pulse is then attenuated by absorption by the CO in the sample cell. The chopped signal, which is modulated by the difference in pulses due to the two gas sensors, is sensed by the detector. The amplitude of the difference is proportional to the concentration of the CO in the sample cell. The specificity of this method to CO is very high since other gases present in the sample cell are equally absorbed by the reference and the measure pulses. In currently available models, the signal is demodulated and amplified using digital circuitry, then processed and linearized using microprocessors. Typical specifications for gas-filter-correlation NDIR analyzers are: ranges of 0-1000 ppm down to 0-1 ppm, accuracy and precision of ± 0.1 ppm, minimum sensitivity of 0.1 ppm, linearity of $\pm 1\%$ of full scale, response time of 60 seconds to 95% of concentration using a 30-second averaging time, and a weight of about 20 kg.

Current costs for both types of NDIR analyzers are in the range of \$6,000 to \$10,000 per unit. Electrochemical analyzers cost in the range of \$800 to \$3,000 per unit. In addition, extra costs must be allowed for, since these analyzers usually need separate data logging and calibration

systems.

As mentioned earlier, the primary advantage to real-time techniques is that short-term peak concentrations can be obtained. The disadvantages are all associated with the high cost of accurately using real-time monitors. They have a high initial cost (analyzer, data logger, calibration system), require daily calibration, and require extensive set-up and removal costs. In addition, a computer is usually needed for reduction of the data to usable concentrations averaged over a specified time-period(s).

Non-specific Active Air Collector. Currently, the most inexpensive technique for sampling indoor and outdoor CO concentrations over an extended period of time (e.g., one week) is the bag collector. Bag collection is an integrating technique. Air is collected into an evacuated sampling bag using an active pump. Low-flow peristaltic pumps are often used to collect one-week air samples. Higher flow rate pumps are used for shorter sampling periods. Most bag-collector units fit into a suitcase-sized container. Once the air sample is collected, it is analyzed in the laboratory using one of the real-time monitors previously discussed. These collectors have been successfully deployed in numerous studies (e.g., Traynor *et. al.*, 1989).

Bag collectors are usually custom-built and cost approximately \$1,500 per unit. This technique is advantageous because (1) real-time, labor-intensive CO analyzers can stay in the laboratory and can analyze the CO concentration in hundreds of bags per week, thus saving considerable amounts of money; (2) bag-collection systems are easily reusable and (3) other stable, non-reactive pollutants, such as air-exchange rate tracer gases or CO₂, can also be measured using the same bag samples. The disadvantage is that short-term CO concentration data are not directly measured. However, short-term concentrations can be modeled if the on/off pattern of the source is known. Appliance on/off patterns can be obtained with electronic on/off sensors or with homeowner-filled diaries.

Non-Specific Passive Air Collector. A passive integrating technique which has just recently become commercially available is the evacuated canister sampler. This technique uses an evacuated stainless steel canister to sample air and uses a flow control system to provide a constant air flow to the canister. A 6-liter evacuated canister with the flow control system costs between \$1,000 and \$1,500. Automated canister sampling, purging, and reevacuation systems (including pumps) can cost as much as \$6,500. The main advantage of evacuated canisters, compared with bag collectors, is that some volatile organic compounds (VOCs) could also be measured using the canister, since certain VOCs that might react in a bag do not react in a properly treated stainless steel canister. One disadvantage of canisters, again compared with bag

collectors, is the initial expense associated with purchasing a reevacuation system.

CO-Specific Biological Measurement Techniques. One way of monitoring CO in an environment is to measure CO concentration in the blood of humans exposed to such an environment. CO combines with the blood's hemoglobin and forms carboxyhemoglobin (COHb). There are a wide variety of methods for measuring CO in blood. The most popular methods discussed in the literature are (1) spectrophotometric methods, (2) gas chromatographic methods, (3) NDIR methods and (4) the Conway Diffusion Cell Method. However, none of these methods is suitable for analyzing indoor CO for two general reasons. First, CO blood levels are a weighted average (sometimes with unknown weighting factors) of the dose of CO the subject received in the various environments previously occupied; thus, the effect of exposure to CO in any given environment cannot be isolated. Second, these methods are costly. For more information on such CO-specific biological measurement techniques, see Commins (1975), Shephard (1983), and WHO (1976).

Measurement of the CO concentration in breath is another biological technique used to estimate CO exposure and is less intrusive than blood measurements. This technique has been successfully used for many years (Shephard, 1983; WHO, 1976; Wallace *et al.*, 1988). The basic concept is to measure alveolar CO at equilibrium with the COHb. Wallace *et al.* (1988) discuss the physiological modeling of this technique with solutions. The model is based on the Coburn differential equation (Coburn, *et al.*, 1965) which is solved analytically. The relationship is dependent on many parameters including lung diffusivity, barometric pressure, water vapor pressure, alveolar ventilation rate, inspired CO pressure, endogenous CO production rate, capillary O₂ pressure, and oxyhemoglobin levels. In order to predict the COHb level, an expired breath sample is collected in a bag after a period of breath holding. The sample is subsequently conditioned to filter out interferences, and then analyzed with an electrochemical or NDIR analyzer. Recent smoking or other transient exposures to CO can skew the results if the subject's COHb is not yet equilibrated. This method can be used in some IAQ field studies although it is quite labor-intensive, requires a trained technician to make the measurements, and gives results that are sometimes difficult to interpret.

Existing CO-Specific Passive Samplers. Passive samplers use diffusion to "collect" the pollutant of interest. The diffusion is driven by the concentration gradient between the concentration in the air being sampled and the zero (or near zero) concentration at the surface of the collection material. There exists several CO passive samplers under this general definition.

The two main categories of existing CO passive samplers are: (1) badge detectors such as the "Heads Up!" CO detector (SIMS Marketing, St. Louis, MO) and the "Quantum Eye" detector (Quantum Group, Inc., San Diego, CA); and (2) passive colorimetric dosimeter tubes such as those manufactured by Sensidyne (Clearwater, FL), National Draeger (Pittsburgh, PA), and Mine Safety Appliances (Pittsburgh, PA).

Badge detectors change color when exposed to high levels of CO (e.g., >100 ppm). Badge detectors can reverse this color change and lighten when exposed to subsequently lower levels of CO (e.g., 1-5 ppm). Such detectors appear to have the ability to protect building occupants from fatal levels of CO if the badge is checked regularly and is noticed when it turns color. However, these detectors cannot quantify average CO concentration because color change is a qualitative measure (at least when the human eye is used as the color-change indicator), and because the color change in each monitor is somewhat reversible, thereby being more sensitive to recent CO concentrations rather than to the average CO concentration.

Passive colorimetric dosimeter tubes are a variant of the pumped color detector tubes used for occupational safety measurements. A sealed glass tube is packed with silica gel beads impregnated with a CO sensitive color-indicator. To deploy, one end of the tube is broken off. CO diffuses down the tube and the length of the indicator stain is measured at the end of the sampling period. Recent research indicates that these tubes are not fully satisfactory for quantitative determination of CO (Hossain and Saltzman, 1989). Problems include poor accuracy and statistically significant humidity effects. At best, these devices are designed to have an accuracy of $\pm 25\%$ at high concentrations and are not suitable for CO passive sampling in residential settings.

CO Passive Samplers Under Development

Because existing CO passive samplers have had their shortcomings, as mentioned above, both LBL and Harvard have sought to develop "ideal" passive samplers, ones that fit the needs of a residential field survey. The two passive samplers that LBL has worked on are the reflective CO passive sampler and a near-infrared-absorbing passive sampler. Harvard has been developing a Zn-Y-zeolite CO passive sampler (Hishinuma and Yanagisawa, 1989). An "ideal" passive sampler is one that can be used to accurately measure the integrated concentration of the gas of interest and one that has an appropriate capacity, accuracy, precision, and sensitivity for residential settings. Ideal passive samplers are also small so that deployment through the mail is possible. Three existing passive samplers (which sample gases other than CO) that pass these requirements are the Palmes NO₂ passive sampler (Palmes *et al.*, 1976), the LBL formaldehyde

passive sampler (Geisling *et al.*, 1982), and a water vapor passive sampler (Palmes *et al.*, 1976; Girman *et al.*, 1986). All three of these passive samplers consist of a closed tube which can be uncapped at one end and which contains a chemical sampling compound at the end which remains closed. Figure 3 shows the configuration of LBL's passive formaldehyde sampler. To deploy, the cap is removed allowing the sampling compound to be exposed. The sampled gas is transported to the closed end by diffusion; the transport rate is given by Fick's Laws of Diffusion and is confirmed by experimental data. A CO passive sampler should also have these ideal characteristics and might have similar design features.

Table 2 presents rough design criteria for a CO passive sampler for IAQ field studies. The criterion for a minimum sensitivity is based on the need for the device to be capable of measuring outdoor CO levels which often range from 1 to 5 ppm. The nominal sampling time is one week, which would measure the average concentration over a complete work-week/weekend life-style cycle. The criterion for the accuracy and precision of the device is based on the need to distinguish between indoor and outdoor levels where very small indoor sources are present (e.g., when the average indoor CO concentration is 2 ppm greater than the outdoor concentration).

Discussed here for completeness are the basics of diffusion dosimetry, a key mechanism in the operation of passive samplers. The mass of CO that diffuses to the sampling compound in a given time can be calculated using Fick's first law. If one assumes 100% collection efficiency, this mass can be described by the following equation.

$$M = \frac{D_{CO}CA t}{L}$$

where:

- M = mass diffused to end of diffusion tube (g);
- D_{CO} = diffusion coefficient for CO in air (cm²/sec);
- C = bulk air CO concentration (g/cm³);
- A = cross-sectional area of tube (cm²);
- t = sampling time (sec);
- L = length of tube (cm).

No measured diffusion coefficient for CO in air was found in the literature; however, it can be estimated for a given temperature and pressure using the Wilke and Lee method (Lyman *et al.*, 1982). Using this method D_{CO} is calculated to be 0.245 cm²/sec at standard temperature and pressure conditions.

LBL's Two CO Passive Samplers. LBL has worked on two types of CO passive samplers, the *reflective* CO passive sampler and the *near-infrared-absorbing* CO passive sampler. The initial development of LBL's reflective CO passive sampler has concentrated on the use of palladium-related compounds (PRC) as the collecting media. A disk of PRC-treated paper is placed at the closed end of the sampling tube. The PRC-treated paper darkens upon exposure to CO. After a prespecified sampling time period, the tube is closed. The degree of darkness of the PRC-treated paper is correlated with the ppm-hours of exposure to CO and can be quantified using a reflectometer. Unfortunately, funding for the project was discontinued before two major advances were completed during the laboratory phase of the CO passive sampler development. These advances were (1) the reduction of the batch-to-batch variation in the "reflectance" of blank (unexposed) PRC-treated paper, and (2) stabilization of the humidity levels in the sampling tube. The LBL reflective CO passive sampler is discussed in greater detail in the next section of this report.

LBL has also begun research on a near-infrared-absorbing CO passive sampler. This CO passive sampler uses a proprietary PRC-based CO-sensing coating on a silica-based circular disk. In the presence of CO, the absorbance of near-infrared radiation through the coated disk increases. Since research on this technique has only recently begun, no performance data is available.

In both of its CO passive samplers, LBL uses palladium-related compounds (PRC's) as the sensing media. Although a large number of chemical methods for measuring CO have been explored and are described in the literature (Shephard, 1983, WHO, 1979), very few are appropriate for use in a diffusion tube configuration. Reasons include instability, insensitivity, and toxicity of the reagents involved. There are three techniques using PRC's in methods for determining CO in air described in the literature which have shown promise for application in a passive sampler. These compounds include potassium pallado sulfite (Silverman and Gardner, 1965; Main-Smith and Earwicker, 1946), a palladous silicomolybdate (Shepherd, 1947; Shuler and Schrauzer, 1977; Palmer *et al.*, 1982), and palladium sulphite (Earwicker, 1960).

Potassium pallado sulfite is a yellow crystalline chemical. On reaction with CO, it forms a carbonyl compound which, at ambient temperatures, decomposes to form CO₂, SO₂, and palladium. As the concentration of palladium metal increases, the system darkens. The reactions which are thought to occur follow.

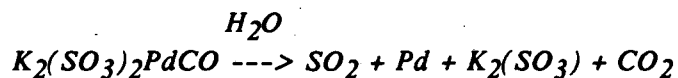
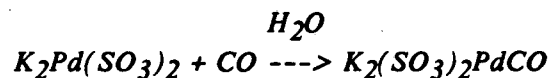

yellow

brown

This method has been used in CO indicator tubes where the compound has been impregnated on highly purified silica gel. The method is sensitive to moisture, which affects the sensitivity and color of the stain and, in the case of high moisture levels, causes a spontaneous deterioration and color change of the impregnated silica gel. The compound has been shown to be insensitive to oxygen, nitrogen and carbon dioxide, but can react with hydrogen sulfide, acetylene, arsine, phosphine and stibene in a manner similar to CO. Temperature effects are small.

The palladous silicomolybdate method was developed originally in 1941 for detection of CO on aircraft (Main-Smith, 1941). In this method, silica gel is impregnated with ammonium molybdate, sulfuric acid and palladium chloride, forming a yellow silicomolybdate complex. The palladium acts as a catalyst for the reduction of the complex by CO. The silica gel provides the water required for the reactions. The resulting products of the reduction are a mixture of oxides of molybdenum and are blue in color. The method was later improved by the National Bureau of Standards by substituting palladium sulfate for palladium chloride, yielding a gel four times as sensitive (Shepherd, 1947). Further innovations to the complex were developed in the 1970's and 1980's by the addition of copper salts to the complex to make the reaction reversible, thereby making detectors reusable (Shuler and Schrauzer, 1977; Palmer *et al.*, 1982). The reversibility is of limited value in the case of CO passive samplers where quantitative results are required. The method has been found to have several interferents including hydrogen sulphide, nitrogen dioxide, acetylene, methylacetylene and ammonia, although the responses to these interferents are unknown. High humidity decreases the sensitivity of the catalyst, and the reaction time decreases with increasing temperature. This method is the basis for some of the CO detector tubes and badges used in industrial hygiene applications.

The use of palladium sulphite has been discussed by Earwicker (1960). It is very sensitive to CO, and its color changes predictably upon exposure to CO. It reacts with CO in nearly dry or humid conditions, which could simplify sampler configuration. The reaction with CO follows.

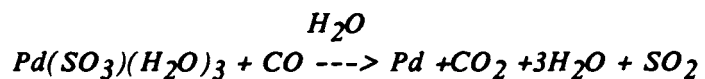

Harvard's CO Passive Sampler. Early results of a third CO passive sampler under development at Harvard have been reported in the literature (Hishinuma and Yanagisawa, 1989). In this sampler the collecting sorbent is a conditioned Zn-Y-zeolite molecular sieve. The sampler has an exposure range of up to 550 ppm-hours in dry conditions and an assumed sensitivity of 30 ppm-hours. Analysis is conducted by thermal desorption of the Zn-Y-zeolite molecular sieve and quantitative conversion of the collected CO to methane. The resultant methane is then measured by gas chromatography with a flame ionization detector. The authors indicate that the capacity of the sorbent is decreased under humid conditions; however, they also propose a method for increasing the range of the device under such conditions.

ECONOMIC COMPARISONS OF CO SAMPLING TECHNIQUES FOR A HYPOTHETICAL LARGE-SCALE INDOOR AIR QUALITY FIELD STUDY

A key issue in field surveys is the cost of measurement, since this factor can determine whether or not a research group undertakes a specific project. Field studies, for example, studies to determine the percentage of malfunctioning combustion appliances or studies to determine the health effects of chronic exposure to low concentrations of CO, require a large number of samples. Since many measurements must be made, the cost of each measurement must be low; otherwise, the expense of the project may be prohibitive. The main expenses in such studies are labor, equipment, and travel. The cost of field setup and calibration of active instrumentation and associated data acquisition systems adds another large expense. The cost of sending a trained technician to a field site drastically increases the cost of measurements. An alternative to field studies, however, is mail-out studies. The size and simplicity of a CO passive sampler suggest that it could be mailed to the sites and deployed with simple instructions, thereby greatly reducing the labor costs of collecting samples. After exposure, the passive sampler would be returned by mail and analyzed at a central laboratory. The benefits of conducting the analysis at a central laboratory include reduced expense of costly analytical equipment as well as better quality control and reduced variability in analysis afforded by the laboratory setting.

Keeping in mind the cost issues mentioned above, three scenarios for conducting an indoor CO concentration study are examined using three different measurement techniques, namely (1) real-time CO analyzers, (2) integrating bag collectors, and (3) CO passive samplers (of the type under development). The intent here is not to fully outline a study design, but to simply compare relative costs of a hypothetical study using the three types of instrumentation discussed above. Each scenario assumes that 500 houses will be studied and that, at a minimum, one-week winter-time average indoor and outdoor CO concentrations are needed. The first two measurement techniques exist; however, the third technique as yet does not. For any IAQ field study, the sample of houses must be pre-selected and a final report must be written. These costs are assumed to be the same for all three scenarios. These costs will not be included in this analysis. For scenarios (2) and (3), ones that do not employ real-time monitors, it is assumed that 1-day follow-up visits will be required in 10% of the houses (i.e., 50 houses) to determine the cause of elevated CO concentrations. An average price of labor has been assumed to be \$50/hour for this analysis.

Real-Time Monitor Scenario. In order to visit and install real-time monitoring equipment in 500 houses in a 12-week winter, it would be necessary to visit 50 houses per week (allowing a 2-week margin of error to deal with any problems). Ten 2-person crews could set-up, remove and move the equipment with one central supervisor. Total hours for collecting data would be 10,080 (21 people x 12 weeks x 40 hours/week) and would cost \$504,000. Data analysis time could easily consume \$40,000 and computer time might cost in the \$5,000-10,000 range. Equipment costs for one of the systems would be \$8,000 for the CO analyzer, \$3,000 for the data logger, and \$3,000 for the calibration and indoor/outdoor switching system for a total price of \$14,000 per unit or \$700,000 for 50 units. Technician training time and travel costs could add another \$100,000 to the project. The total cost of monitoring 500 houses with real-time monitors would be about \$1.35 million (or approximately \$2,700 per house). Some cost-savings in equipment could be accomplished by monitoring over several winters, yet, not enough to justify this approach.

Bag-Collector Scenario. Using bag collectors would save equipment costs and field-technician time. Ten people with one supervisor could set up and remove the sampling equipment in 500 houses, since bag-collectors are much easier to handle and deploy. This would result in field labor costs of \$264,000. Data analysis and computer costs would also be reduced, since only two values per house would be obtained (total estimate = \$20,000). Equipment costs for 50 packages of one indoor and one outdoor bag sampler at \$1500 each would be \$150,000. Training and travel costs would be approximately \$50,000, one-half the cost of using real-time monitors. Follow-up costs are estimated to be \$1,000 per house or \$50,000 for 50 houses. Total study costs would be \$534,000 (or \$1,070 per house).

Passive Sampler Scenario. By using a passive sampler in a mail-out mode, the cost of technician time for field work could be greatly reduced, since only 10% of the houses would be visited. Data analysis and computer costs would be the same as for the bag-collector scenario (i.e., \$20,000). Preparation and use of large quantities of passive samplers cost, at most, \$50 each, using the Palmes tube as a guide. One thousand samplers (plus 20% for controls, quality checks, etc.) would be needed in the study for a total cost of \$60,000. Although there would be little travel and training costs, special handling and mailing costs of approximately \$20,000 would be needed. Follow-up visits and quality-control checks would cost \$60,000. Total costs would be \$160,000 (or approximately \$300 per house.)

Although there are many explicit and implicit assumptions in these estimates of sampling costs, it is very clear that passive samplers can drastically reduce the cost of field monitoring studies. Thus, for economic reasons, the development of CO passive samplers should be pursued if a

technically-feasible approach exists. Differing costs and/or assumptions would not alter the conclusions of this approximate analysis.

STATUS OF THE LBL REFLECTIVE CO PASSIVE SAMPLER

The development of a CO passive sampler is justified because of the low cost associated with its utilization and because of the need to further investigate CO in indoor environments. As was described in greater detail above, the Lawrence Berkeley Laboratory has partially developed two passive samplers for indoor CO measurement. The first technique (the reflective technique) employs a paper disk treated with a palladium-related compound (PRC) placed at one end of a diffusion tube. As the disk is exposed to CO, it becomes irreversibly darker due to the increased concentration of black metallic palladium. This darkening can be measured with a reflectometer. The second technique (the near-infrared-absorbing technique) employs a proprietary formulation of palladium and other compounds coated onto a porous, clear, silica-based disk. As the disk is exposed to CO, the absorbance of near-infrared radiation through the disk is increased. This change in absorbance can be measured using a spectrophotometer. Because research on this second technique has only recently begun, the discussion immediately following will concern itself with the first reflective technique. Further laboratory research on the reflective technique is needed to (1) minimize humidity effects; (2) reduce batch-to-batch variation; (3) improve analytical instrumentation; (4) evaluate the effect of any interferences; (5) quantify sensitivity, precision, and accuracy of the sampler; and (6) evaluate sampler shelf life. Any CO passive sampler using an alternate CO-sensing technique would require similar research. In addition, any CO passive-sampling technique, once developed, would need to be validated in the field.

The LBL Reflective CO Passive Sampler

In the research conducted by LBL on the reflective CO passive sampler, the reflectivities of the paper disks were measured with a simple reflectometer. Response to CO was shown to be linear with respect to the log of the normalized reflectance. Initial testing of the dosimeter showed a strong humidity dependence. The sampler was then redesigned in an attempt to stabilize the sampler's response to CO over a wide range of humidities. Figure 4 shows the response before humidity stabilization, and Figure 5 shows the effect of stabilization. The samplers in both cases were exposed to controlled atmospheres near 5 ppm of CO for different lengths of time. Four lots of samplers were exposed to atmospheres with relative humidity ranging from 0% to 80%. The response of the stabilized samplers is uniform for all relative humidities of 30% or greater. Linearity within a batch of stabilized samplers was good, although it was found to vary from batch to batch. The measured sensitivity of the passive sampler is better than 30 ppm-hours, and its capacity has been tested up to 500 ppm-hours using a simple reflectometer. No field testing has been done to date.

Humidity-Effect Minimization. Preliminary tests of LBL's reflective CO passive sampler have shown that humidity affects the rate of PRC-disk color-change. Two options exist to correct this problem. One, a different palladium compound, insensitive to humidity, could be used; unfortunately, none has been found to date. Two, the humidity in the tube could be stabilized. This is best done at either 0% or 100% relative humidity. Several ideas in this area have been developed but need to be tested in the laboratory.

Batch-to-Batch Variation. Preliminary tests of LBL's reflective CO passive sampler have shown that there is a significant difference in the background or "blank" reflectance between batches of PRC-treated paper. If this variation persists, it would be necessary to save blanks from every batch of PRC-treated paper and to keep track of which disks went into each sampler. This procedure would make sampler handling and laboratory analyses more complex and expensive, but the procedure may still be manageable. Using advanced coating techniques to coat the disks might overcome this problem; however, such techniques would need to be tested in the laboratory.

Analytical Instrumentation. A relatively unsophisticated reflectometer has been used in the development process. It measures reflectance over a large range of visible-light wavelengths. A more sophisticated instrument could measure the reflectance at the most sensitive wavelength, thereby reducing the signal-to-noise ratio and improving the sensitivity, precision, and accuracy of the technique.

Interferences. In laboratory validations, particular attention must be paid to potential interferences. There are two types of interferences. The first is related to the sampler preparation and analytical methods, and can be dealt with quite readily. Second, interferences can result from substances present in the environment in which the samplers ultimately will be used. The best way to deal with interferences is to have some knowledge of the potential types of environments in which the passive samplers will be used, and to know what pollutants could theoretically interfere with the sampler. A testing program should be conducted to evaluate the effects of potential interferences as part of the laboratory-validation studies.

Sensitivity, Precision and Accuracy. Once the final configuration of the passive sampler has been determined, the sensitivity, precision, and accuracy of the sampler need to be evaluated. To make this evaluation, a real-time EPA-approved NDIR CO analyzer needs to be used. The sensitivity goal of the passive sampler is to be able to detect 168 ppm-hours or less, i.e., 1 ppm or less over a one-week period. The sensitivity (also called the limit of detection) of the passive sampler is related to the distribution of the measurements from blank samples that are not

exposed to CO. If one is confident that the measurement in question is statistically discernable (using a t-test) from the distribution of measurements from blank samples, then one should be confident that the sample was exposed to a measurable amount of CO. The sensitivity of a technique is often expressed as twice the absolute standard deviation of the response distribution of blank samples and should approximate twice the absolute precision of that technique at low exposure levels. The precision of the device can be determined by simply taking a large number of samples exposed to the same concentration and calculating the relative standard deviation. Different concentrations should be used to evaluate precisions over the range of expected concentrations. To determine the accuracy of the technique under laboratory conditions, the CO passive sampler should be tested over a wide range of exposure values. The CO concentrations and CO exposure values (concentration x time) should be monitored with a standard reference method such as an EPA-approved NDIR CO analyzer. Standard linear regression analyses will yield an error term, and thus an accuracy, for the CO concentration measured by the CO passive sampler. Insight into the linearity of the technique will also be gained.

Shelf Life and Capacity. Ideally, the samplers should have long shelf lives both before and after deployment. In addition, they should have adequate capacity to sample over a one-week period. In the real world, shelf lives and saturation levels need to be quantified. Standard methods exist for measuring both aspects in the laboratory.

Field Research Needed for the Validation of Any CO Passive Sampler

The final test for any passive sampler is field-validation. It is important for field testing any passive sampler that (1) a wide range of pollutant concentrations are encountered in the field test, (2) a sufficient number of samplers are tested; and (3) a reliable "standard" test for the pollutant is obtained simultaneously (in time and space) with the passive sampler.

Most houses are expected to have an indoor CO concentration less than 10 ppm. However, it would be desirable to test the CO passive sampler in environments with average CO concentrations of 20 ppm or 30 ppm. It may be necessary to artificially create high-CO environments to properly validate the sampler if only low CO concentrations are obtained during the course of the field tests.

A minimum of 30 (ideally 60) passive samplers would need to be deployed during winter-time conditions, when higher indoor CO concentrations are expected. Thirty is typically chosen as a minimum number for testing in these situations because the critical value of "t" used in

statistical confidence interval tests (t-tests) of normal distributions stabilizes at sample sizes of 30 or more. Thirty houses sampled for indoor and outdoor CO would yield 60 samples and should be adequate for field validation. Additional inside and outside testing of houses in summertime conditions should also be done if a temperature effect is observed during laboratory tests. If a humidity effect or interferent is observed during laboratory tests, a subset of passive samplers monitoring sites should have measurements of humidity or the interferent.

The best reference method to use for testing the performance of the CO passive sampler in the field would be an integrated bag collector coupled with a subsequent sample analysis using an EPA-approved NDIR CO analyzer. The integrated bag sampler is needed to collect a sample over the same time-period as the passive sampler. Results of the field study should be initially analyzed using standard linear regression techniques. Additional analysis may be warranted if humidity, temperature, interferent, or any other effect is observed.

CONCLUSIONS AND RECOMMENDATIONS

Conclusions

- (1) There is evidence indicating that hundreds of fatal and thousands of non-fatal CO poisonings occur in the U.S. every year. A significant fraction of these poisonings are associated with the use of both vented and unvented gas appliances.
- (2) A properly-designed field research study using CO passive samplers is needed to evaluate indoor CO concentrations to determine if these concentrations pose a health threat to the occupants. A CO passive sampler would greatly facilitate the conduction of such a study.
- (3) Several techniques exist that show promise for developing a low-cost and effective method (i.e., a CO passive sampler) for measuring indoor CO concentrations. These potential CO passive sampling techniques are LBL's reflective technique, LBL's near-infrared-absorbing technique, and Harvard's Zn-Y-zeolite technique.

Recommendations

- (1) Develop and field-validate a CO passive sampler suitable for a field research-study.
- (2) Conduct a properly-designed field research study to evaluate indoor CO concentrations and to identify the specific factors which lead to high indoor CO concentrations.
- (3) Start targeted mitigation, appliance-replacement, and/or appliance-maintenance programs, if warranted by the field-study results, to reduce the risk of indoor CO poisonings and to ensure the safe use of gas as an energy-efficient space-heating, water-heating, and cooking fuel.

ACKNOWLEDGEMENTS

The authors thank John Girman (currently with the U.S. Environmental Protection Agency, Washington, D.C.) for his early work on LBL's reflective CO passive sampler; Gregg Filler (LBL) for manuscript preparation; and Joan Daisey (LBL), David Faulkner (LBL), John Little (LBL), Irv Billick (Gas Research Institute, Chicago, Il), Marilyn Keller (Pacific Gas & Electric Company, San Ramon, CA), and Kathy Godfrey (Pacific Gas & Electric Company, San Ramon, CA) for reviewing the manuscript. The ideas expressed in this report are those of the authors and may not represent the views of the Pacific Gas & Electric Company or the reviewers.

REFERENCES

- ACGIH (1980) *Dosimetry for Chemical and Physical Agents*. Seventh Annual American Conference of Governmental Industrial Hygienist Topical Symposium. Cincinnati, OH.
- Akland G.G., Hartwell T.D., Johnson T.R. and Whitmore R.W. (1985) Measuring Human Exposure to CO in Washington, D.C., and Denver, Colorado, During the Winter of 1982-1983. *Environmental Science & Technology* 19, 911-918.
- Atkins E.H. and Baker E.L. (1985) Exacerbation of Coronary Artery Disease by Occupational CO Exposure: A Report of Two Fatalities and a Review of the Literature. *American Journal of Industrial Medicine* 7, 73-79.
- Barret L., Danel V. and Faure J. (1985) Carbon Monoxide Poisoning, A Diagnosis Frequently Overlooked. *Clinical Toxicology* 23, 309-313.
- Bartlett D. (1968) Pathophysiology of Exposure to Low Concentrations of CO. *Archives of Environmental Health* 16, 719- 727.
- Beatty L. (1955) *Methods for Detecting and Determining Carbon Monoxide*. Bulletin 557. Bureau of Mines. U.S. Government Printing Office. Washington, D.C.
- CARB (1982) *California Ambient Air Quality Standards for Carbon Monoxide (Sea Level)*. California Air Resources Board, Sacramento, CA.
- Caplan Y.H., Thompson B.C., Levine B. and Masemore W. (1986) Accidental Poisonings Involving CO, Heating Systems, and Confined Spaces. *Journal of Forensic Sciences* 31, 117-121.
- Cobb N. and Etzel R.A. (1991) Unintentional Carbon Monoxide-Related Deaths in the United States, 1979 Through 1988. *Journal of the American Medical Association* 266, 659-663.
- Coburn R. F., Forster R. E. and Kane P. B. (1965) Considerations of the Physiological Variables that Determine the Blood Carboxyhemoglobin Concentration in Man. *Journal of Clinical Investigation* 44, 1899-1910.
- Commins (1975) Measurement of Carbon Monoxide in the Blood: Review of Available Methods. *Annals of Occupational Hygiene* 18, 67-77.
- Dolan M.C., Haltom T.L., Barrows G.H., Short C.S. and Ferriell K.M. (1987) Carboxyhemoglobin Levels in Patients with Flu-Like Symptoms. *Annals of Emergency Medicine* 16, 782-786.
- Earwicker C. A. (1960) The Sulphito-Compounds of Palladium(II). *Journal of the Chemical Society* 2, 2620.
- Eklblom B. and Huot R. (1972) Response to Submaximal and Maximal Exercise at Different Levels of Carboxyhemoglobin. *Acta Physiologica Scandinavica* 86, 474-482.
- Fisher J. and Rubin K.P. (1982) Occult Carbon Monoxide Poisoning. *Archives of Internal Medicine* 142, 1270-1271.
- Geisling K.L., Tashima M.K., Girman J.R., Miksch R.R. and Rappaport S.M. (1982) A Passive Sampling Device for Determining Formaldehyde in Indoor Air. *Environment International* 8, 153-158.

Girman J.R., Traynor G.W. and Hollowell C.D. (1982) *A Carbon Monoxide Passive Monitor: A Research Need*. Lawrence Berkeley Laboratory, Report No. LBID-501, Berkeley, CA.

Girman J.R., Allen J.R. and Lee A.Y. (1986) A Passive Sampler for Water Vapor. *Environment International* 12, 461-465.

Hishinuma M. and Yanagisawa Y. (1989) Passive Sampler for Carbon Monoxide Using a Solid Adsorbent. Paper No. 89-82.4. *Proceedings of the 82nd Annual Meeting of the Air and Waste Management Association*, Anaheim, CA, June 25-30, 1989.

Hossain M.A. and Saltzman B.E. (1989) Laboratory Evaluation of Passive Colorimetric Dosimeter Tubes for Carbon Monoxide. *Applied Industrial Hygiene* 4, 119-125.

Johnson C.J., Moran J.C., Paine S.C., Anderson H.W. and Breyse P.A. (1975) Abatement of Toxic Levels of Carbon Monoxide in Seattle Ice-Skating Rinks. *American Journal of Public Health* 65, 1087-1090.

Kelley J.S. and Sophocleus G.J. (1978) Retinal Hemorrhages in Subacute Carbon Monoxide Poisoning Exposures in Homes with Blocked Furnace Flues. *Journal of the American Medical Association* 239, 1515-1517.

Kleinman M.T. and Whittenberger J.L. (1985) *Effects of Short-Term Exposure to Carbon Monoxide in Subjects with Coronary Artery Disease*. University of California, Irvine, CA.

Lambert W.E. and Samet J.H. (1988) The Role of Combustion Products in Building-Associated Illness. University of New Mexico, Albuquerque, NM (unpublished manuscript).

Lao Y.J., Smith R.W., Rich T.L. and Davis T.G. (1982) Carbon Monoxide Levels in Homes With Fuel-Burning Space Heaters. *Journal of Environmental Health* 44, 180-182.

LBL (1976) *Instrumentation for Environmental Monitoring: Air Gases, Part 1A*. Lawrence Berkeley Laboratory, Berkeley, CA.

Longo L.D. (1977) The Biological Effects of CO on the Pregnant Woman, Fetus, and Newborn Infant. *American Journal of Obstetrics and Gynecology* 129, 69-103.

Lyman W. J., Reehl W. F. and Rosenblatt D.H. (1982) *Handbook of Chemical Property Estimation Methods: Environmental Behavior of Organic Compounds*, McGraw-Hill Book Co., New York, New York.

Main-Smith J.D. (1941) Royal Aircraft Establishment Report CH 324.

Main-Smith J.D. and Earwicker G. (1946) Improvements in or Relating to the Detection and Quantitative Determination of Carbon Monoxide in Air or Other Gases at Such Temperatures as Occur in the Atmosphere and Reagents Therefore. Patent Specification 582,184, The Patent Office, London, England.

Marsh B.T. (1982) Housing and Health The Role of the Environmental Health Practitioner. *Journal of Environmental Health* 45, 123-128.

McFarland R.A. (1973) Low Level Exposure to Carbon Monoxide and Driving Performance. *Archives of Environmental Health* 27, 355- 359.

McFee D.R., Lavine R.E. and Sullivan R.J. (1970) Carbon Monoxide, Prevalent Hazard Indicated by Detector Tabs. *American Industrial Hygiene Association Journal*. 31: 749.

Novick R.E. (1972) Urban Anthropology: The Emerging Science of Modern Man. *The Science Teacher* 39, 21-22.

NRC (1981) *Indoor Pollutants*. National Research Council, National Academy of Sciences. Washington, D.C.

Palmer J. G., Cecil M., Schrauzer G. N. and Shuler K. E. (1982) *Preparation and Evaluation of Self-Regenerative Carbon Monoxide Detection Gels*. A Minerals Research Contract Report, Bureau of Mines, U.S. Department of the Interior, Report No. OFR 92-83.

Palmes E.D., Gunnison A.F., DiMattio J. and Tomczyk C. (1976) Personal Sampler for Nitrogen Dioxide. *American Industrial Hygiene Association Journal* 37, 570-577.

Pierson R.H., Aaron N.F., and St. Clair Cantz E. (1956) Catalog of Infrared Spectra for Qualitative Analysis of Gases. *Analytical Chemistry* 28, 1218.

Radford E.P. (1973) *Survey of Carbon Monoxide in East Baltimore Housing -- A Preliminary Report*. John Hopkins University. Baltimore, MD.

Rench J.D. and Savage E.P. (1976) Carbon Monoxide in the Home Environment: A Study. *Journal of Environmental Health* 39, 104-106.

Schaplowsky A.F., Oglesbay F.B., Morrison J.H., Gallagher R.E. and Berman W. (1974) Carbon Monoxide Contamination of the Living Environment: A National Survey of Home Air and Children's Blood. *Journal of Environmental Health* 36, 569-573.

Sexton K., Liu K. and Petreas M.X. (1986) Formaldehyde Concentrations Inside Private Residences: A Mail-Out Approach to Indoor Monitoring. *Journal of the Air Pollution Control Association* 36, 698-704.

Shephard R.J. (1983) *Carbon Monoxide: The Silent Killer*. Thomas Books: Springfield, IL.

Shepherd M. (1947) Rapid Determination of Small Amounts of Carbon Monoxide. Preliminary Report on the NBS Colorimetric Indicating Gel. *Analytical Chemistry* 19, 77-81.

Shuler K. E. and Schrauzer G. N. (1977) Catalyst and Method for Oxidizing Reducing Gases. U.S. Patent 4,043,934.

Silverman L. and Gardner G. (1965) Potassium Pallado Sulfate Method for Carbon Monoxide Detection. *Industrial Hygiene Journal* March-April, 97-105.

Slusher G.R. (1966) *An Evaluation of Low-Cost Carbon Monoxide Indicators*. Report No. ADS-80. Federal Aviation Agency. Aircraft Development Service. Washington, D.C.

Traynor G.W. *et al.* (1989) Macromodel for Assessing Residential Concentration of Combustion-Generated Pollutants: Model Development and Preliminary Predictions for CO, NO₂ and Respirable Suspended Particles. Lawrence Berkeley Laboratory, Report No. LBL-25211, Berkeley, CA.

USDHHS (1982) Carbon Monoxide Intoxication - A Preventable Environmental Health Hazard. U.S. Department of Health and Human Services, Center for Disease Control, *Morbidity and Mortality Weekly Report* 31 529-530.

USDHHS (1986) *Vital Statistics of the United States, 1984: Volume II - Mortality, Part A*. U.S. Department of Health and Human Services, Public Health Service, National Center for Health Statistics. Hyattsville, MD.

USEPA (1974) *Symposium on the Development and Usage of Personal Monitors for Exposure and Health Effect Studies*. U.S. Environmental Protection Agency. Chapel Hill, NC.

USEPA (1984) *Revised Evaluation of Health Effects Associated with Carbon Monoxide Exposure: An Addendum to the 1979 EPA Air Quality Criteria Document for Carbon Monoxide*. EPA-600/8-83-033F. Environmental Criteria and Assessment Office. U.S. Environmental Protection Agency, Research Triangle Park, NC.

USFR (1971) U.S. Federal Register 36(228), 22384.

USFR (1975) U.S. Federal Register, 40(33), Part II, February 18.

Wallace L., Thomas J., Mage D. and Ott W. (1988) Comparison of Breath CO, CO exposure, and Coburn Model predictions in the U.S. EPA Washington-Denver (CO) study. *Atmospheric Science* 22,2183-2193.

WHO (1976) *Selected Methods of Measuring Air Pollutants*. World Health Organization. Geneva, Switzerland.

WHO (1979) *Carbon Monoxide: Environmental Health Criteria 13*. World Health Organization. Geneva, Switzerland.

Table 1. Techniques available for measurement of carbon monoxide in indoor air quality field surveys.

Method	Resolution	Sampling technique	Method of analysis	Minimum sensitivity	Range	Accuracy ± Precision	Cost per unit	Cost per field measurement	Training required for Deployment	Comments
Double-beam NDIR	Real-time	Mechanical pump	Absorption in Infrared	0.5 ppm	0 - 50 ppm to 0 - 1000 ppm	1% ± 1% of full scale	>\$5000	>\$100	Trained technician, field visit required	Does not include data acquisition costs
Gas filter correlation NDIR	Real-time	Mechanical pump	Absorption in Infrared	0.1 ppm	0 - 1 ppm to 0 - 1000 ppm	0.1% ± 0.1% of full scale	>\$5000	>\$100	Trained technician, field visit required	Does not include data acquisition costs
Electro-chemical	Real-time	Mechanical pump or diffusion	Electro-chemical cell	1 ppm	0 - 1000 ppm	1% ± 2% of full scale	\$800 to \$3000	>\$100	Trained technician, field visit required	Some models include data acquisition costs
Bag samplers	Integrated over sample period	Peristaltic pump into sample bag	Infrared or electro-chemical analysis of collected sample	<1 ppm (average)	0 - 1000 ppm	See infrared or electro-chemical analysis	\$1000 to \$2000	>\$50	Field visit required	
Evacuated canisters	Integrated over sample period	Flow control across vacuum	Same as bag samplers	<1 ppm (average)	0 - 1000 ppm	See infrared or electro-chemical analysis	\$1000 to \$1500	>\$50	Field visit required	
Badge detectors	Integrated over sample period	Sensor in direct contact with air	Visual color change with exposure	One type turns grey at approx. 50 ppm for 24 hours. See Appx. A	NA	NA	\$10	<\$25	Mail-out with instructions	Qualitative only. Primarily used as a warning device. Reversible
Passive colorimetric dosimeter tubes	Integrated over sample period	Color indicating gel in diffusion tube	Visual inspection of stain length	6.3 ppm	50 to 600 ppm-h	>25%	\$3.5	<\$25	Mail-out with instructions	Maximum sampling time is 8 h
LBL reflective passive sampler	Integrated over sample period	Treated disk at end of diffusion tube.	Measure change in reflectance of disk using reflectometer	<30 ppm-h	<30 to >500 ppm-h	Unknown	\$10 (estimate)	<\$25 to \$50	Mail-out with instructions	Method under development
Zn-Y-Zeolyte passive sampler	Integrated over sample period	Diffusion of sample onto solid adsorbent	Thermal desorption of sample into G.C.	30 ppm-h	30 to 550 ppm-h	Unknown	Unknown	Unknown	Mail-out with instructions	Method under development. Temperature and humidity effects unknown

Table 2. Design criteria for a carbon monoxide passive monitor for use in indoor air quality field surveys.

Sampling Period:	Nominal one week (unattended)
Range:	1 to 100 ppm-weeks
Minimum Sensitivity:	1 ppm-week (168 ppm-hrs)
Accuracy:	± 1 ppm for a one-week exposure ($\pm 20\%$ for one-week average concentration > 5 ppm)
Precision:	± 1 ppm for a one-week exposure ($\pm 20\%$ for one-week average concentration > 5 ppm)
Unexposed Shelf-life:	Baseline drift < 1 ppm-week in six months
Sampling temperature range:	0 to 30 °C
Exposed Shelf-life:	Exposed value drift < 1 ppm-week in one month (irreversible process)
Interferences:	< 0.4 ppm for a one-week exposure ($< 8\%$ for one-week average concentrations > 5 ppm)
Storage Temperature Range:	-10 to 40 °C
Analytical Technique:	Preferably simple technology
Cost per Sampler:	\$25 to \$35
Cost per Analysis:	\$25 to \$35

Table 3. Potential Sources of Indoor Combustion Pollutants.

Source	Type of Ventilation
<u>Space-Heating Sources:</u>	
Unvented gas space heaters (convective and infrared)	Unvented
Unvented kerosene space heaters (convective and radiant)	Unvented
Airtight wood stoves	Gravity flue
Non-airtight wood stoves	Gravity flue
Forced-air furnaces (gas and oil)	Gravity flue
Gravity-air furnaces	Gravity flue
Gas, oil and coal water boilers	Gravity flue
Gas floor heaters	Gravity flue
Gas ranges (used for space heating)	Unvented
<u>Other Sources:</u>	
Cigarette smoke	Unvented
Gas cooking ranges without hoods	Unvented
Gas cooking ranges with hoods	Mechanical ventilation
Charcoal cooking	Unvented
Gas water heaters	Gravity flue
Gas dryers	Gravity flue
Fireplaces	Gravity flue
Indoor motor vehicles	Unvented

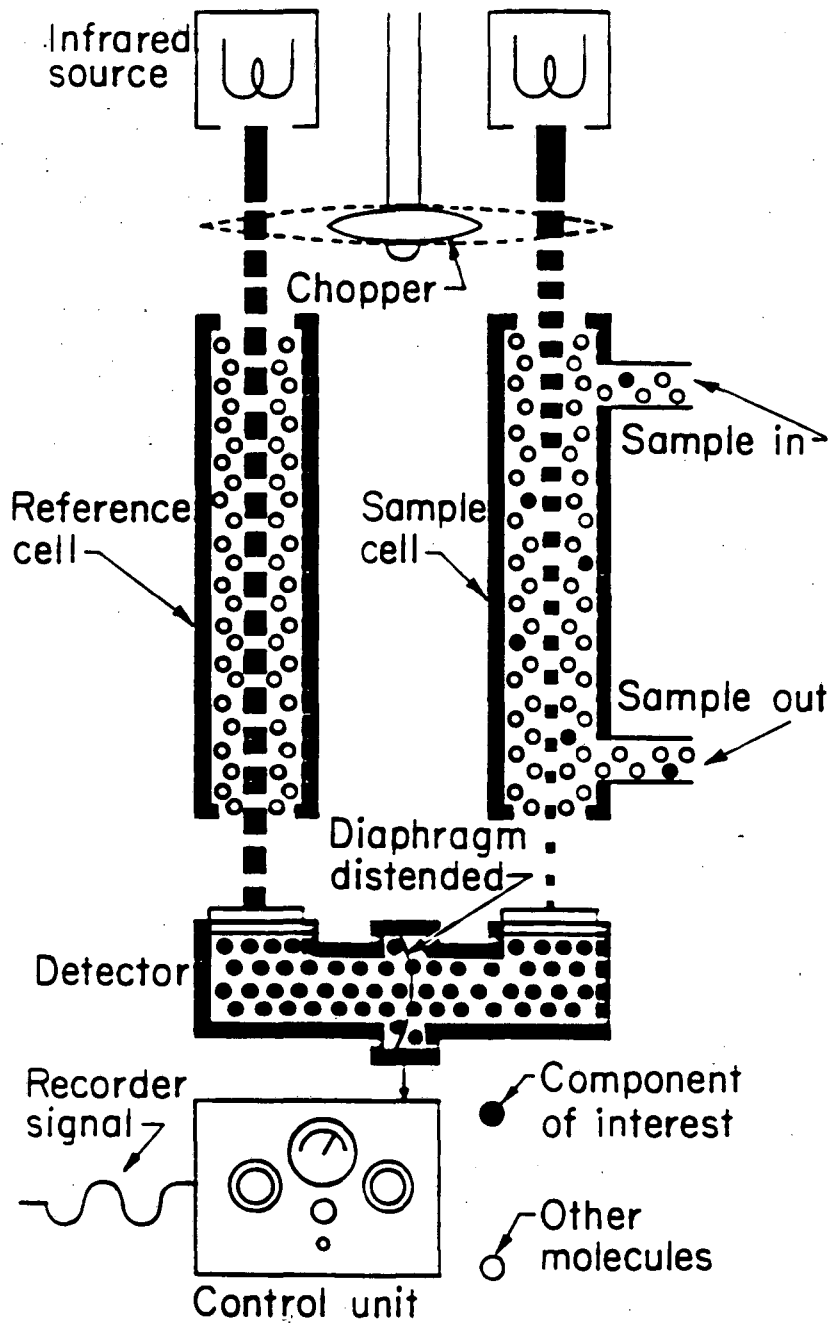

XBL726-3104

Figure 1. Nondispersive infrared analyzer.

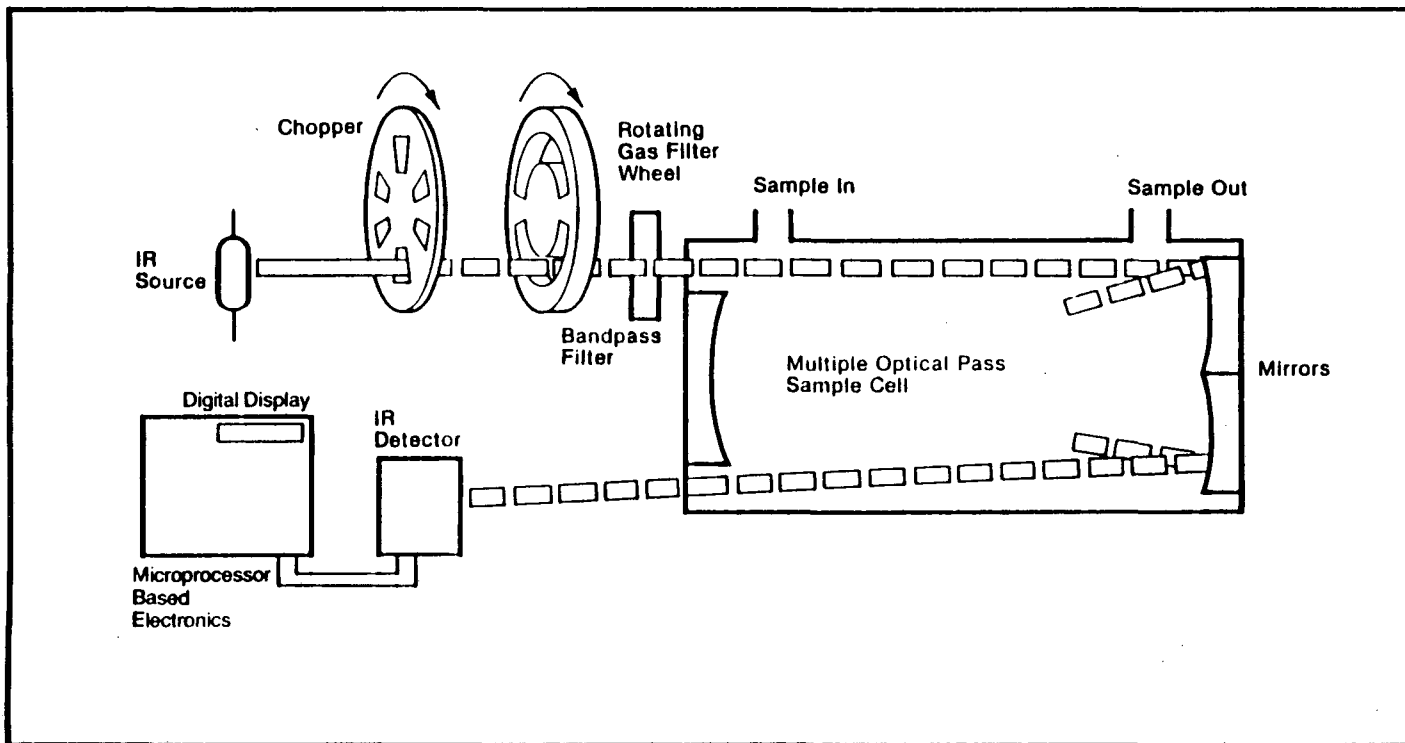
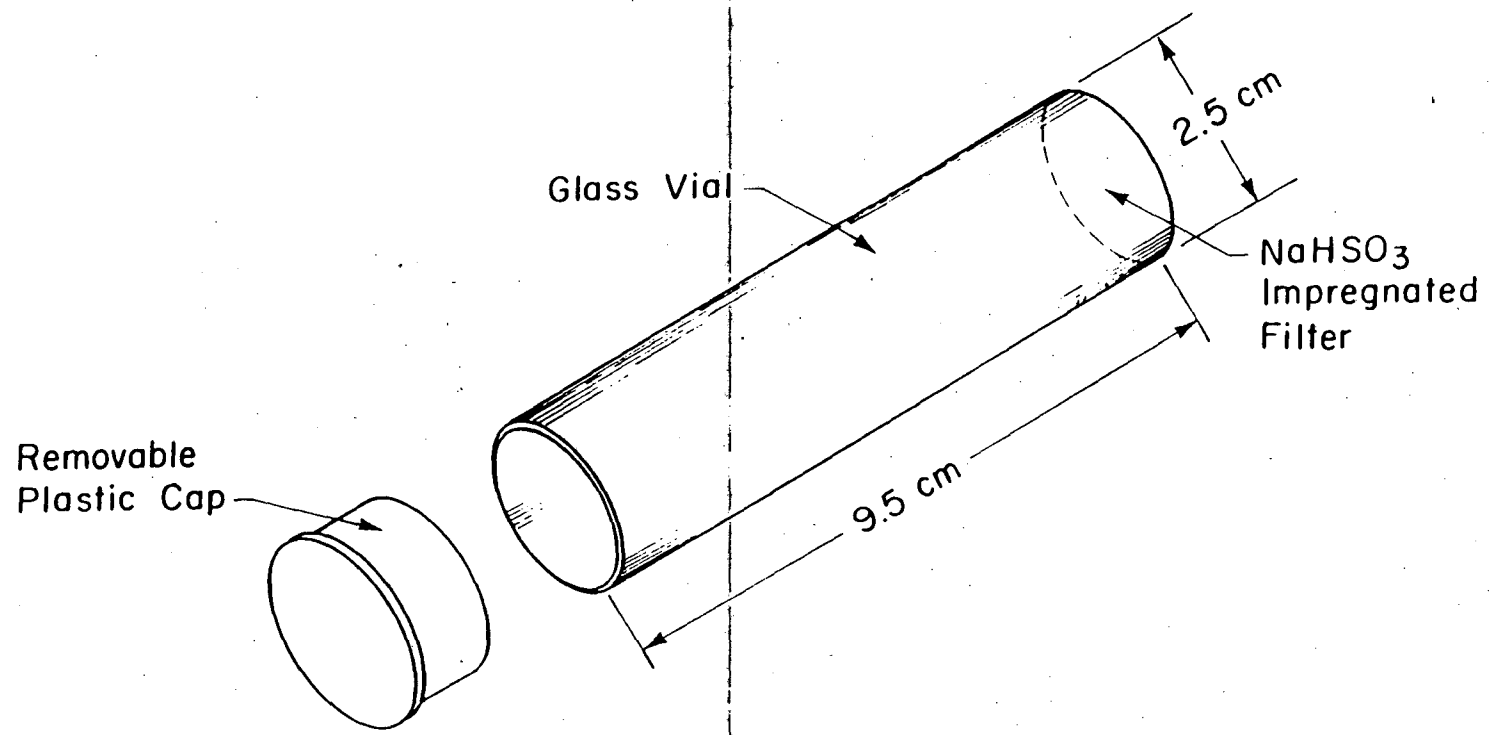

Figure 2. Gas filter correlation analyzer. Diagram from Thermo Environmental Instruments Inc. (Instruments Division), Franklin, MA.

HCHO Passive Sampler



XBL 828 - 1079

Figure 3. LBL's formaldehyde passive sampler.

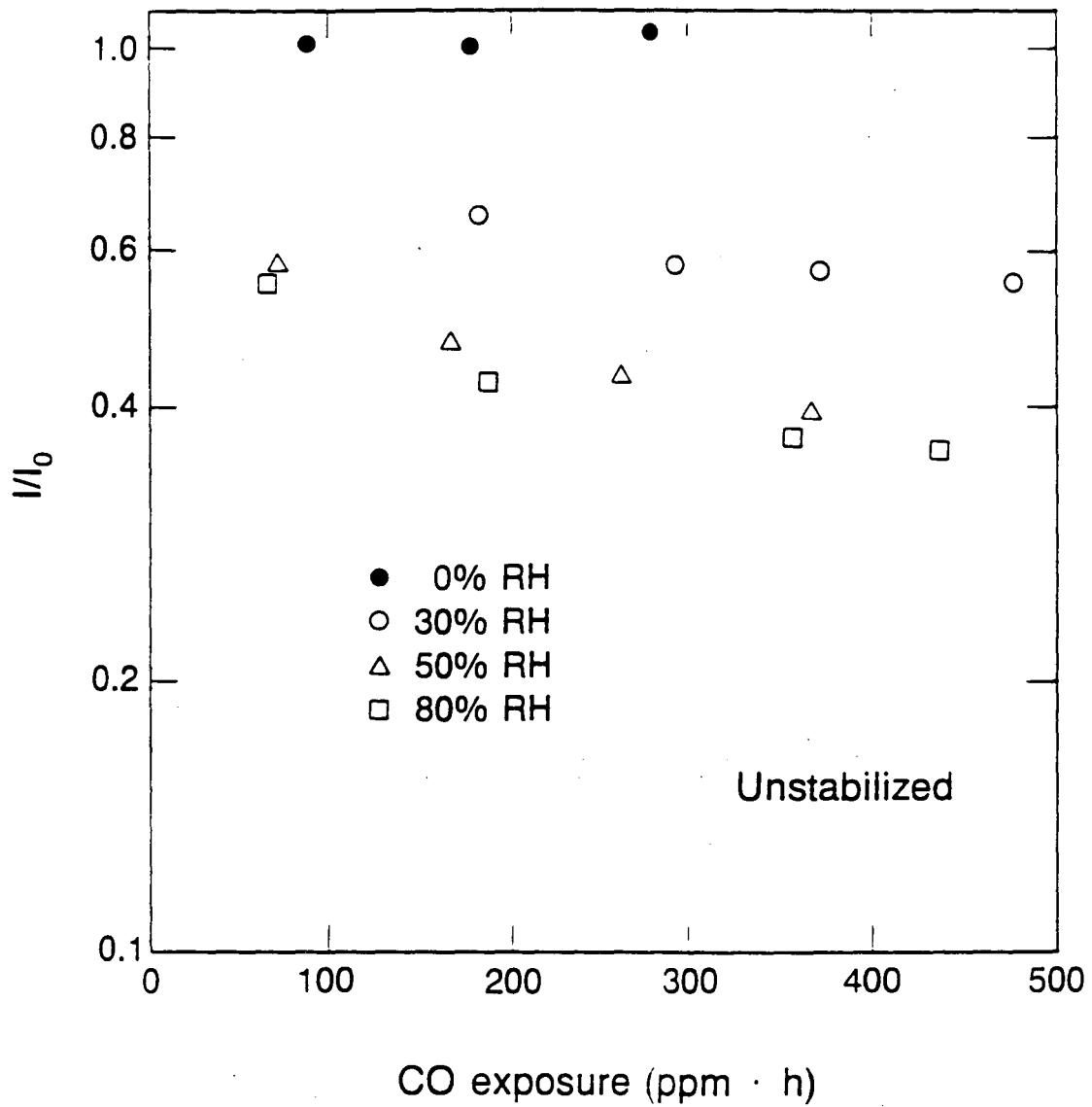

XBL 8312-7401A

Figure 4. Intensity response of LBL's reflective CO passive sampler before humidity stabilization at a CO concentration of approximately 5 ppm.

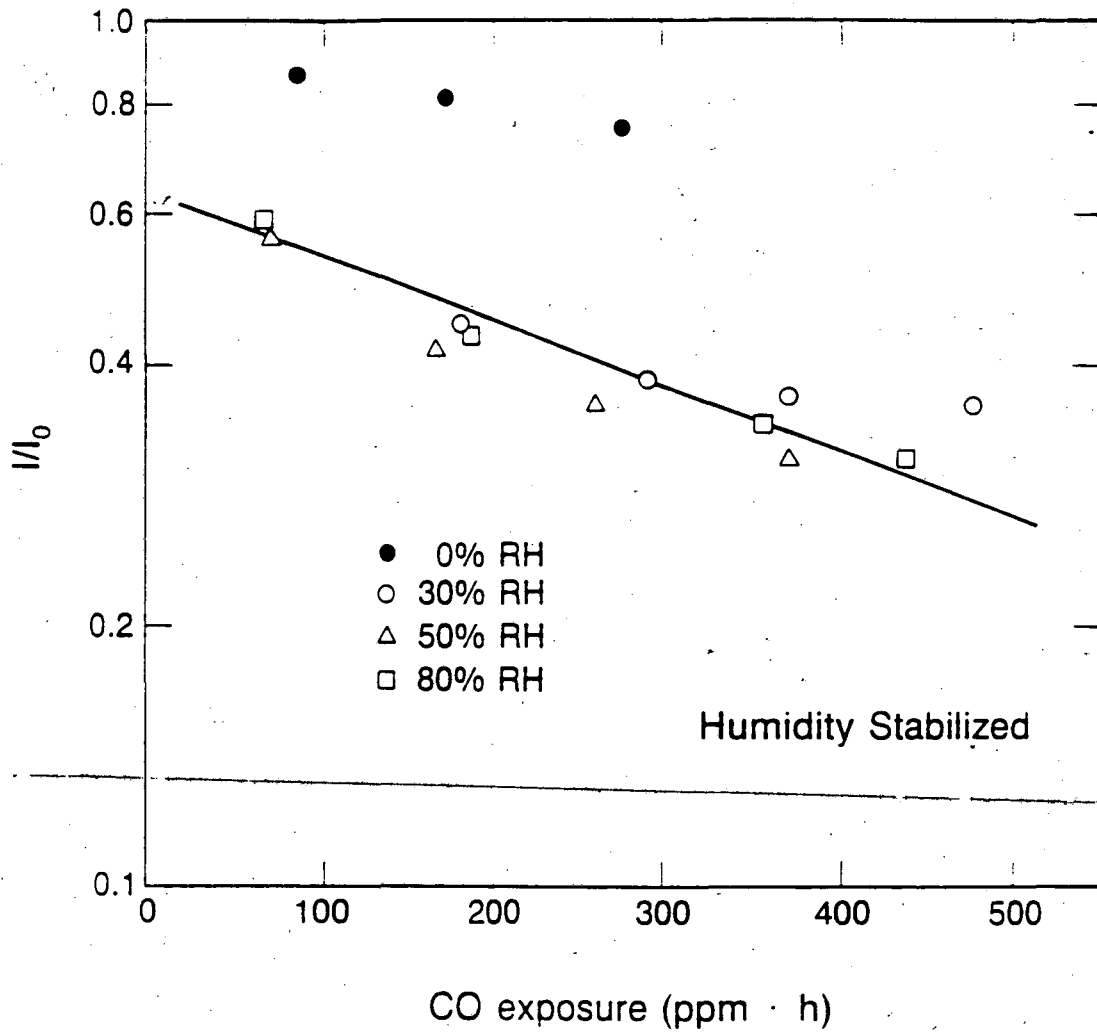

XBL 8312-7402A

Figure 5. Intensity response of LBL's reflective CO passive sampler after humidity stabilization at a CO concentration of approximately 5 ppm.

LAWRENCE BERKELEY LABORATORY
UNIVERSITY OF CALIFORNIA
INFORMATION RESOURCES DEPARTMENT
BERKELEY, CALIFORNIA 94720