

Distribution System Control and Automation

Barry Mather (NREL) and Kevin Schneider (PNNL)

Distribution Systems and Planning Training
for Mid-Atlantic Region and NARUC-NASEO Task Force on Comprehensive Electricity Planning
March 7-8, 2019

What do we mean by distribution system control and automation?

Distribution Automation (DA): uses sensors and switches with advanced control and communications technologies to automate feeder switching; voltage and equipment health monitoring; and outage, voltage and reactive power management.¹

DA provides benefits to utilities and customers promising:

- Shorter outages
- Improved system resilience during extreme weather
- More effective equipment maintenance
- More efficient use of line crews
- Improved integration of DERs

¹ Distribution Automation: results from the smart grid investment grant program, DOE, Sept. 2016.

Spectrum of DA – Simple Systems to Complex System of Systems

Simple – Loop Recloser Automation

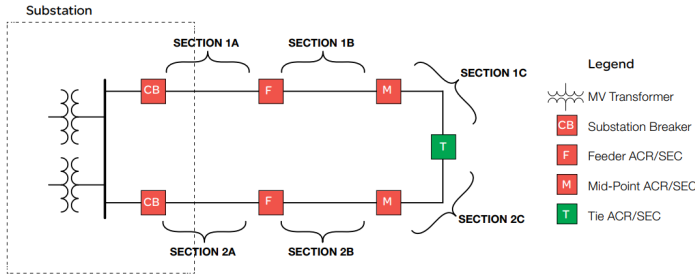

- Usually serve a single function
- Equipment controlled is bound locally
- Relative number of potential operating scenarios is limited/reasonable

Complex - Advanced Distribution Management System

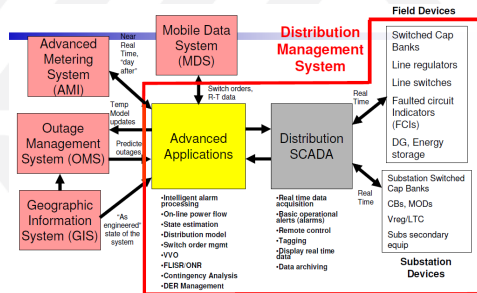

- Serves many functions (co-optimization)
- Equipment controlled is vast and varied
- Systems are seamlessly integrated

DA Example: Loop Recloser Automation

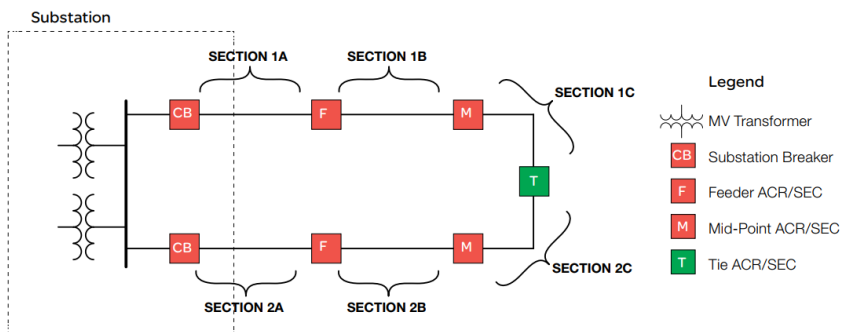

Goal: decrease outage duration/impact

Operation: Two adjacent feeders are upgraded with controllable reclosers/circuit breakers including an automatic “tie” recloser. Following a fault the line section containing the fault is identified and the circuit is reconfigured to provide power to the most customers possible until the fault can be cleared by line crews

DA Example: Automatic Reconfiguration

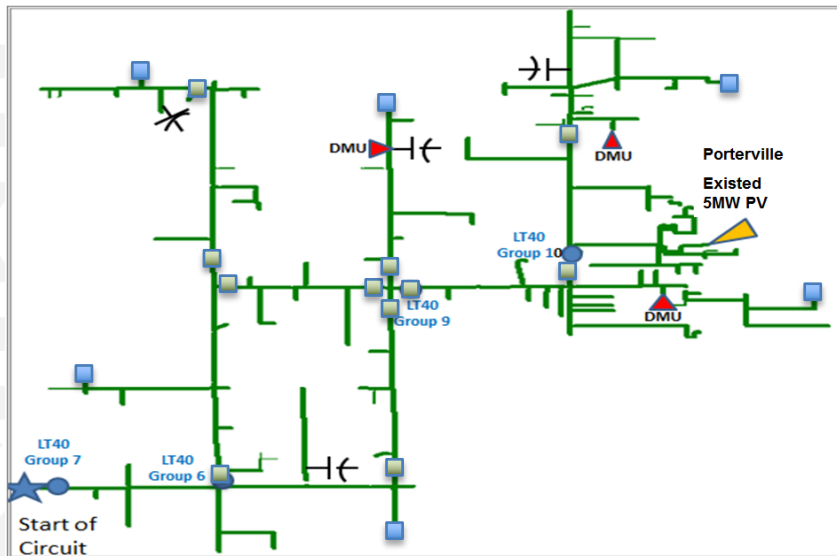

Goal: decrease outage time, balance substation load, manage voltage profiles, etc.

Operation: Sections of the circuit are connected to adjacent feeders

DA Example: Conservation Voltage Reduction (CVR)

Conservation Voltage Reduction (CVR): A voltage reduction scheme that flattens and lowers the distribution system voltage profile to reduce overall energy consumption.

- Works best with circuits with high amounts of resistive loads
- Normally performed by flattening the system voltage using capacitor banks and/or voltage regulators and lowering the voltage by controlling a substation Load Tap Changer
- Also related to central volt/VAR optimization performed by a distribution management system (DMS)

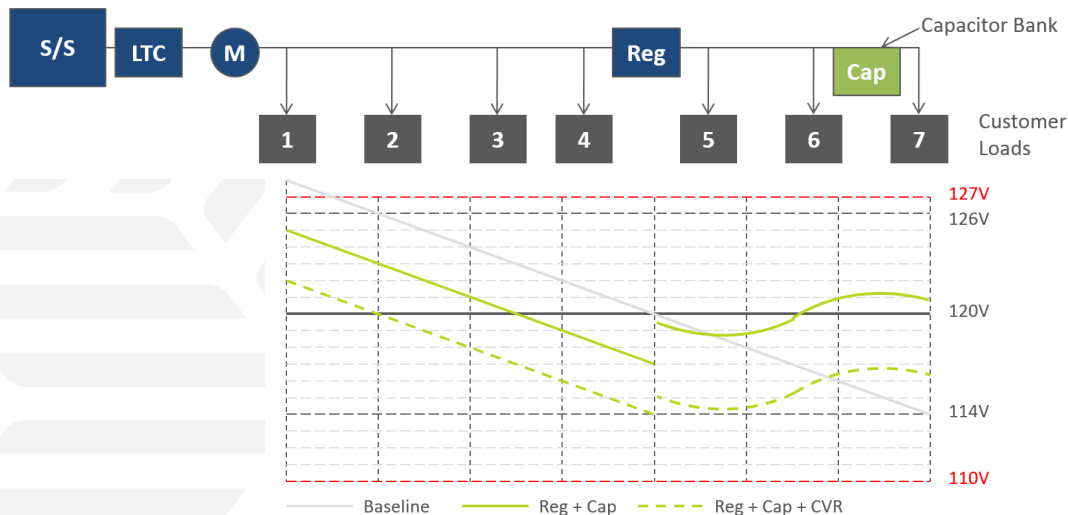
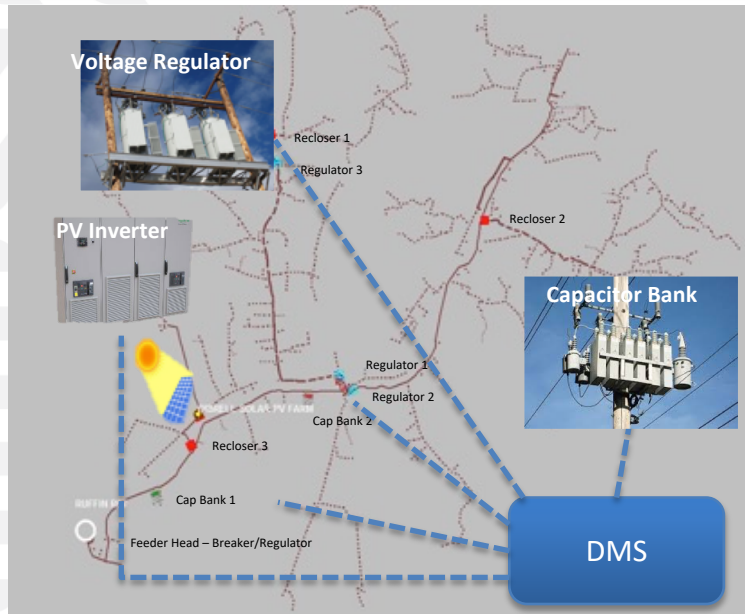

Figure courtesy of Joe Paladino

DA Example: Conservation Voltage Reduction (CVR)

Conservation Voltage Reduction (CVR): A voltage reduction scheme that flattens and lowers the distribution system voltage profile to reduce overall energy consumption.

- Works best with circuits with high amounts of resistive loads
- Normally performed by flattening the system voltage using capacitor banks and/or voltage regulators and lowering the voltage by controlling a substation Load Tap Changer
- Also related to central volt/VAR optimization performed by a distribution management system (DMS)



DA Example of Value: CVR at AEP

- AEP's Objective: Apply data from end-of-line sensors to automatically control line voltage regulators and load tap changers at substation feeder head. Also, coordinate capacitors to keep power factor of the substation transformer near unity (manage substation efficiency)

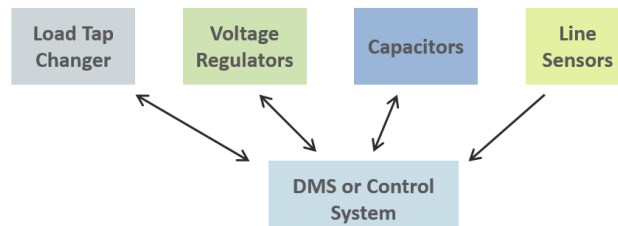

Near-real-time feedback loop enables optimized operation of these components.

| Results Averaged across 11 Circuits | Initial Results | Potential Customer Savings (estimated for a 7 MW peak circuit with 53% load factor) | |
|-------------------------------------|-----------------|---|--------------------------------------|
| Customer Energy Reduction | 2.9% | 943 MWh/year | \$75,440 (at \$.08/kWh) |
| Peak Demand Reduction | 3% | 210 kW | Defer construction of peaking plants |

Figure courtesy of Joe Paladino

DA Example of Value: CVR Business Case at Dominion Virginia Power

- Dominion VA Power's Objective: Using AMI (Smart Meters) as voltage sensors to enable CVR.
- Value Determination: Of the multiple value streams the enablement of CVR provided the highest overall value
- This project is a good example of the value stacking capability of DA/DMS

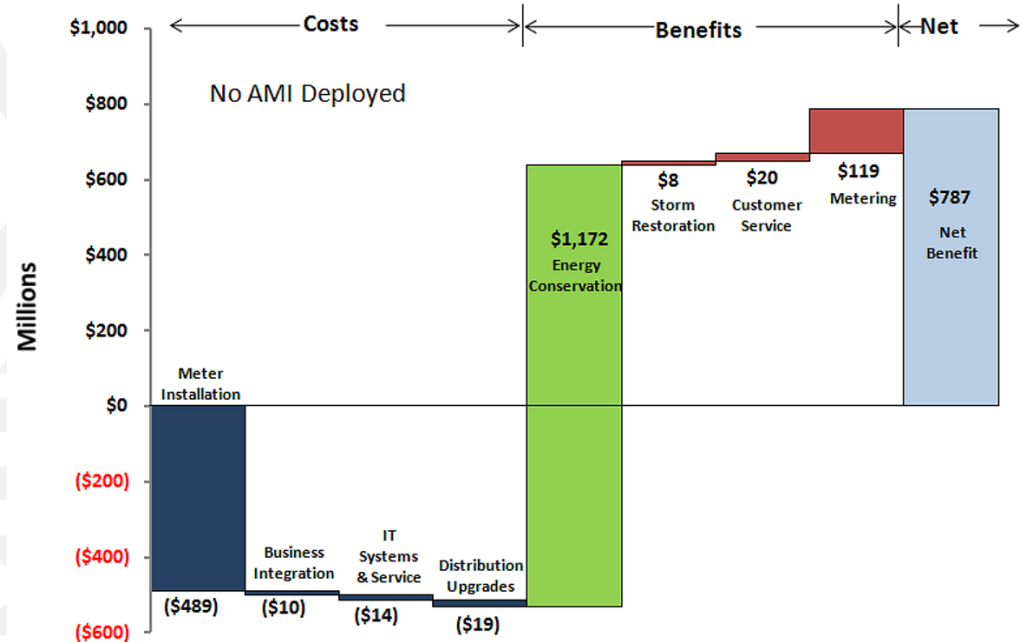
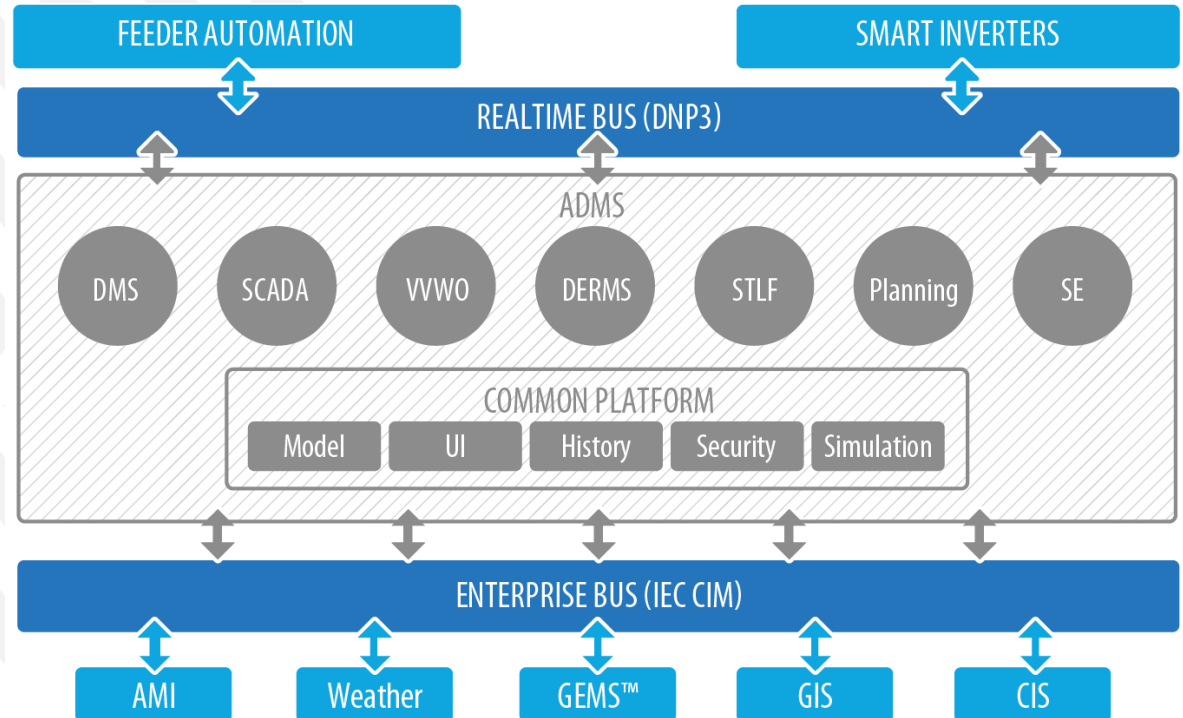

Figure courtesy of Joe Paladino

Advanced Distribution System Management Systems (ADMS)

- The “Whole Enchilada”
- Consist of a Seamlessly Integrated “System of systems”
- Typically sharing common platform
- Data used for management is used for other analytics and data from other systems (i.e. billing) is leveraged for control and optimization
- Application-wise: you’re limited only by your imagination



Distributed Energy Resource Management System (DERMS)

- DERMS provide situational awareness, control/dispatch and monitoring of DERs in the distribution system:
 - PV with and without smart inverters
 - Energy storage
 - Electric vehicles
 - May include demand responsive load



ADMS Testbed

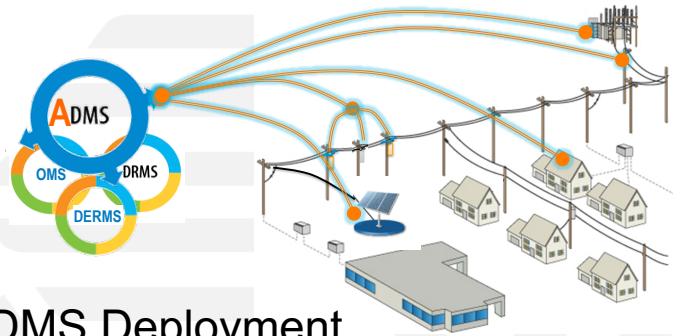

Actual ADMS Deployment

- Tools to model large scale distribution systems for evaluating ADMS applications
- Integrate distribution system hardware for power hardware-in-the-loop (PHIL) experimentation
- Develop advanced visualization capability

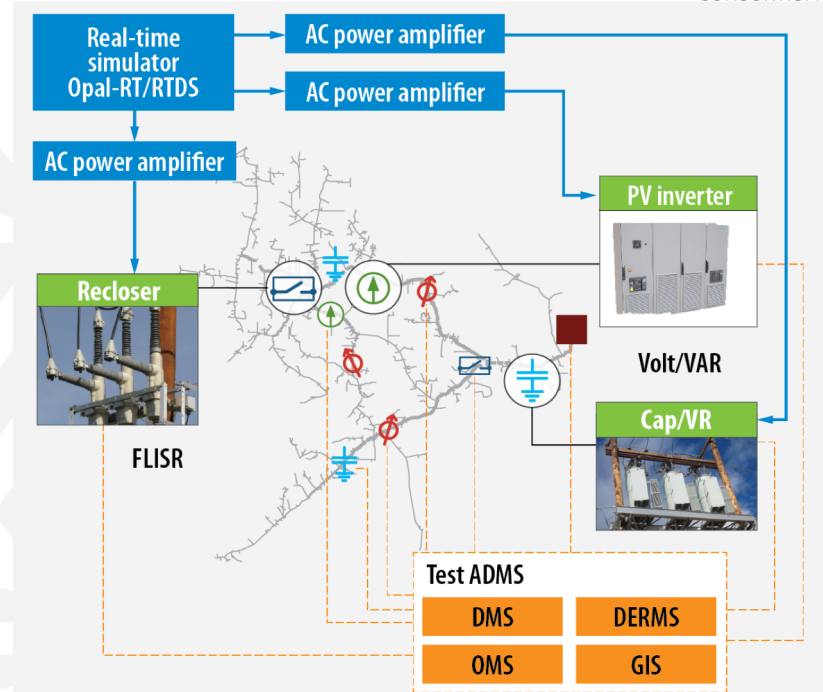

Legend

- Substation
- ⊕ Voltage regulator (VR)
- ⚡ Capacitor bank (Cap)
- ⊕ PV inverter
- ⊞ Recloser

ADMS Case Study

Case Study: Feeder Voltage using Advanced Inverters and a DMS

Objective:

Understand advanced inverter and distribution management system (DMS) control options for large (1–5 MW) distributed solar photovoltaics (PV) and their impact on distribution system operations for:

- Active power only (baseline);
- Local autonomous inverter control: power factor (PF) $\neq 1$ and volt/VAR (Q(V)); and
- Integrated volt/VAR control (IVVC)

Approaches:

- Quasi-steady-state time-series (QSTS)
- Statistics-based methods to reduce simulation times
- Cost-benefit analysis to compare financial impacts of each control approach.

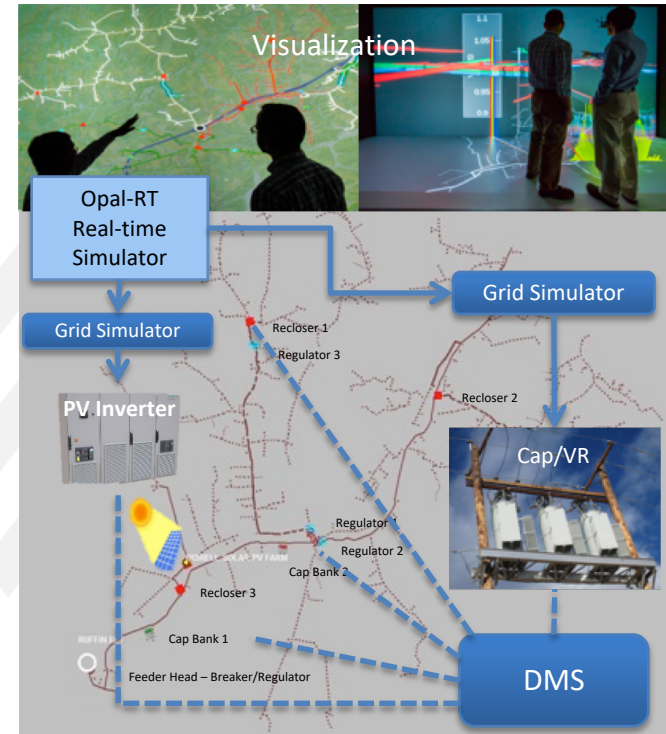

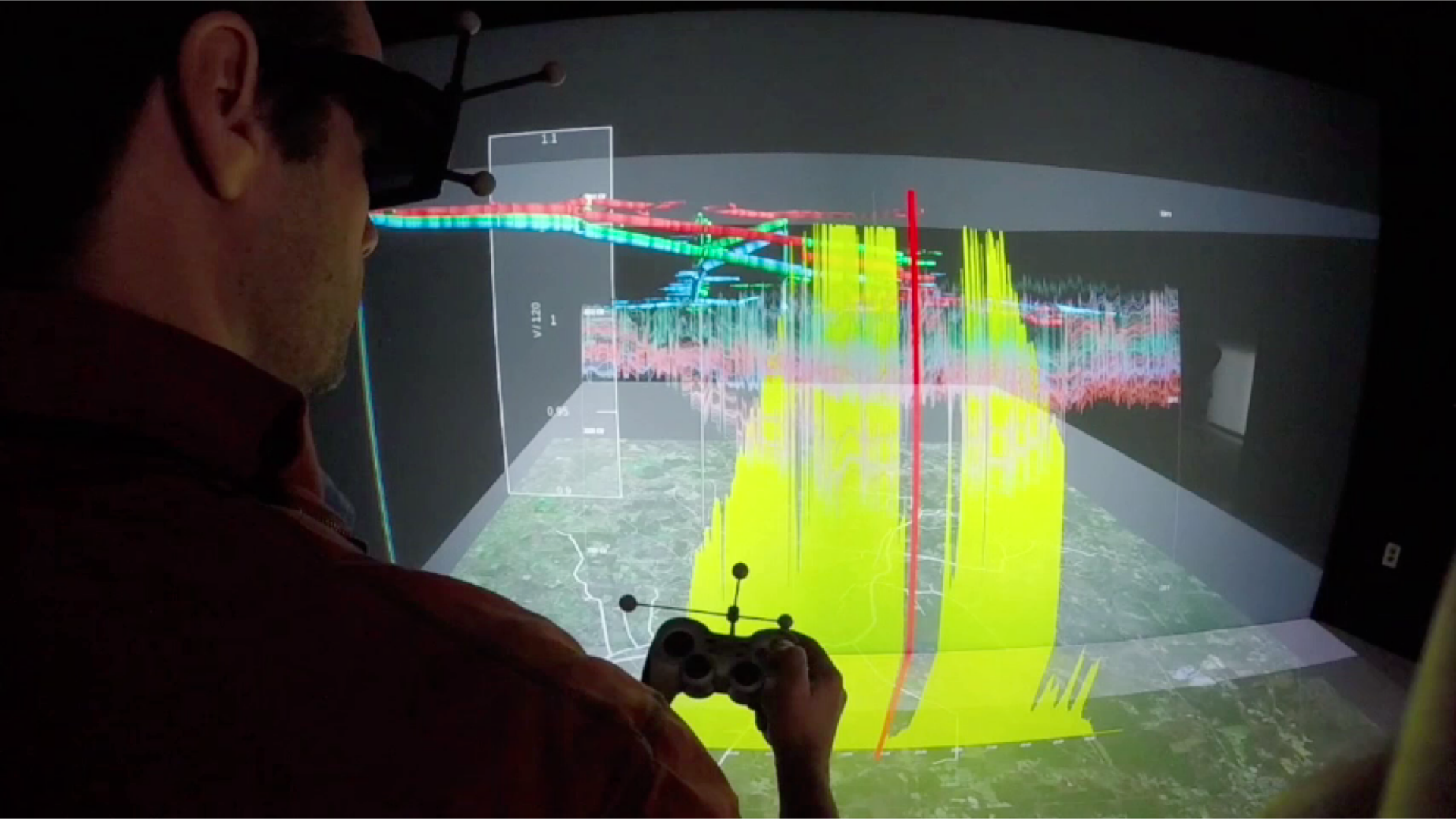

Study System Characteristics

| Feeder Characteristics | |
|---|----------------------|
| Substation primary/secondary voltage (kV LL) | 44/13.5 |
| Substation transformer (MVA/%X) | 10/6.84 |
| Feeder head gang-operated regulators, set of three (kVA/%X) | 250/6.25 (each) |
| Feeder head X/R | 4.25 |
| P(Est. Native) _{annual avg} (MW) | 1.71 |
| P(Est. Native) _{peak} (MW and date) | 5.26 (Jan. 30, 2014) |
| P(Measured) _{annual avg} (MW) | 0.678 |
| P(Measured) _{min} (MW) | -3.72 |
| Capacitor Banks (number/total kVAR) | 2/900 |
| Line Regulator groups | 1x3-phase, 2x2-phase |
| PV Plant Characteristics | |
| Commission date | March 2013 |
| Plant rating (MW _{DC} /MW _{AC}) | 6.4/4.8 |
| PV recloser X/R | 1.82 |
| Distance to substation (overhead line miles) | 1.75 |

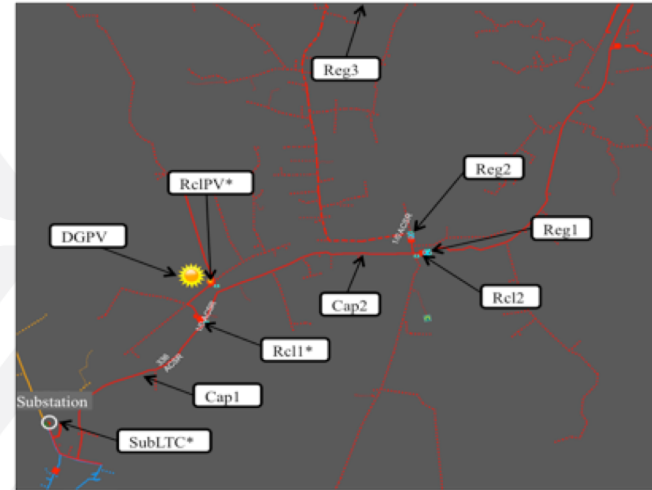

- Cap1: A 450-kVAR (150 kVAR per phase) VAR-controlled capacitor with temperature override. Cap2: A three-phase 450-kVAR capacitor (always disconnected unless controlled otherwise by IVVC)
- Reg1: A set of three single-phase 167-kVA regulators with a voltage target of 123
- Reg2: A set of two single-phase 114-kVA regulators on phase B and phase C with a voltage target of 123 V;
- Reg3: A second set of two single-phase 76.2-kVA regulators on phase B and phase C with a voltage target of 124 V;

Local Control Modes for the PV Inverter

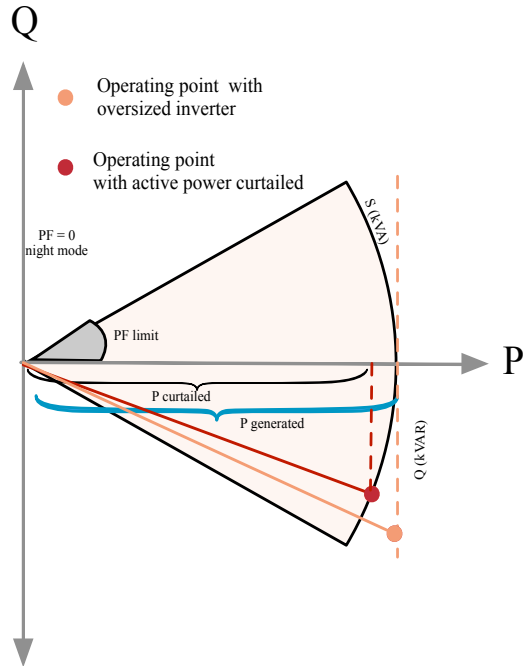

➤ Constant Power Factor Set Point

➤ Volt/VAR Curves

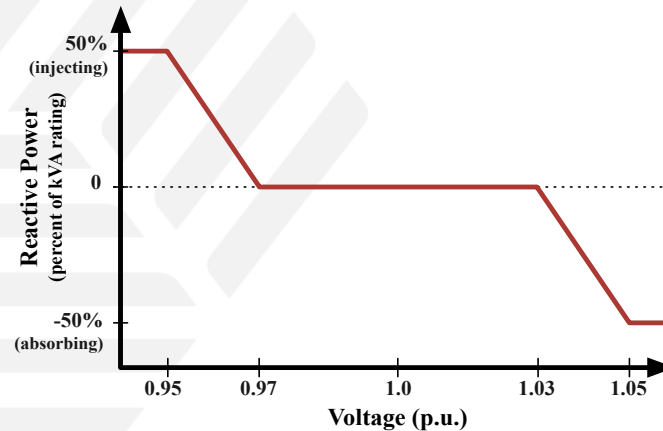

Simulation Scenarios Developed to Show Value of Increasingly Complex ADMS

- ▶ Baseline
- ▶ Local PV Control (PF = 0.95)
- ▶ Local PV Control (Volt/VAR)
- ▶ Legacy IVVC* (Exclude PV)
- ▶ IVVC with PV @ PF 0.95
- ▶ IVVC (Central PV Control)

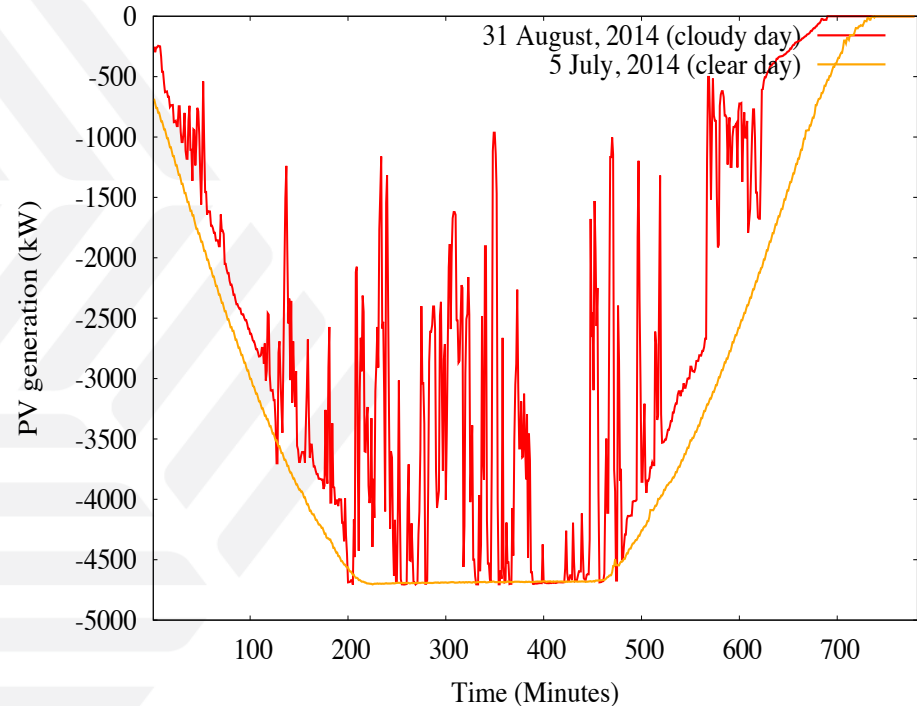

*IVVC = Integrated volt/var control, i.e. VVO

Baseline Results

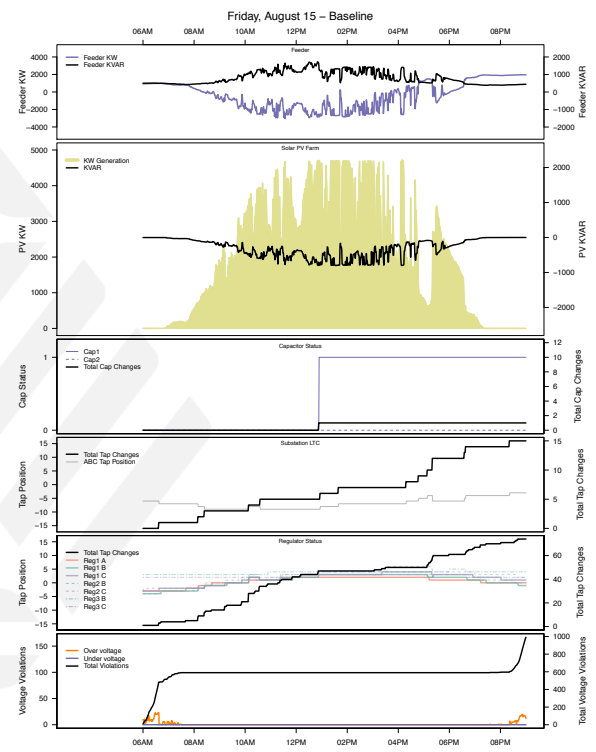
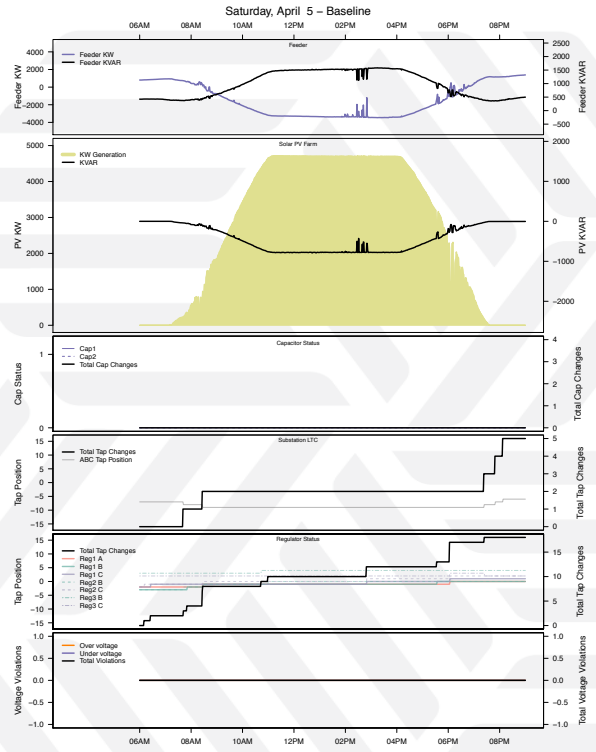

Autonomous Local Control

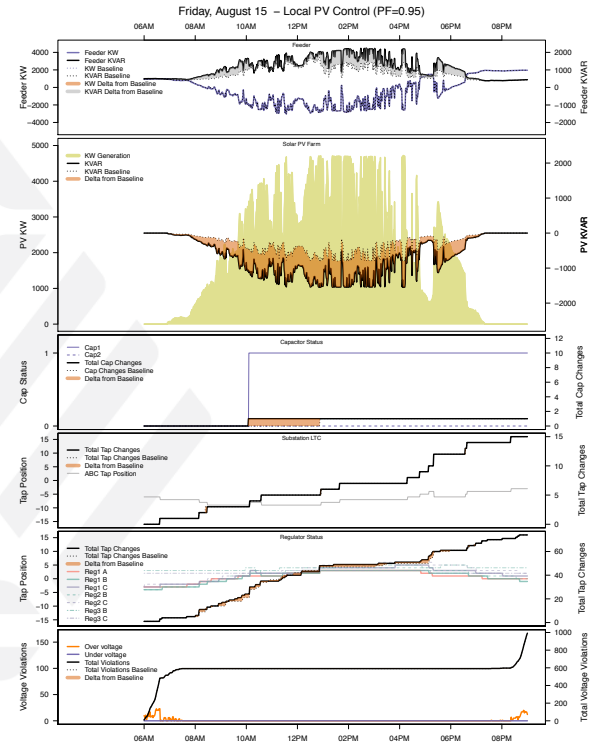
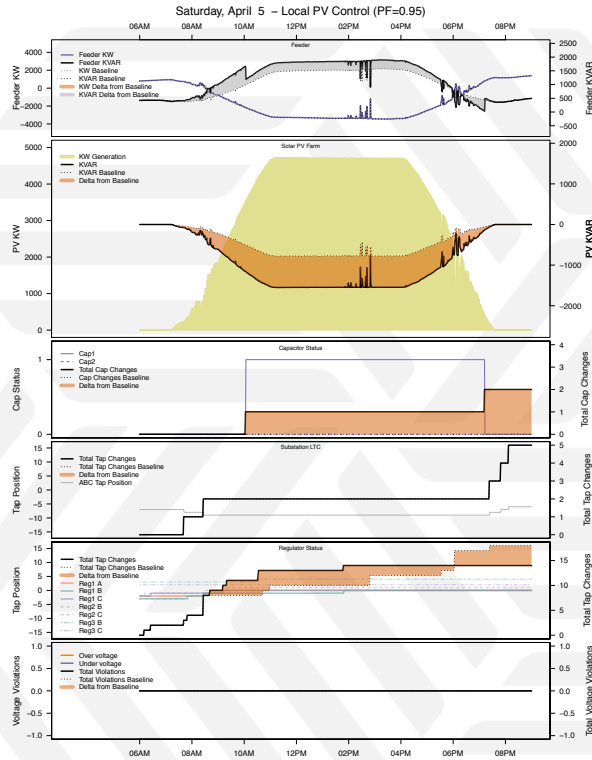

Local Volt/VAR Control

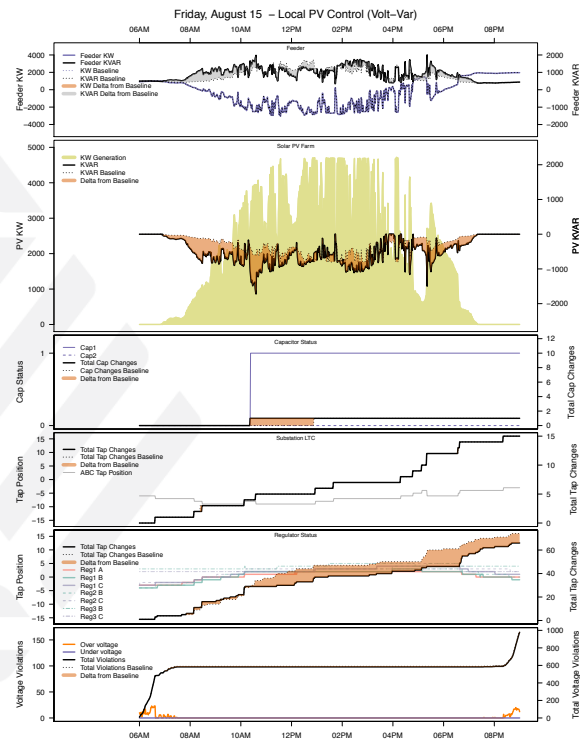
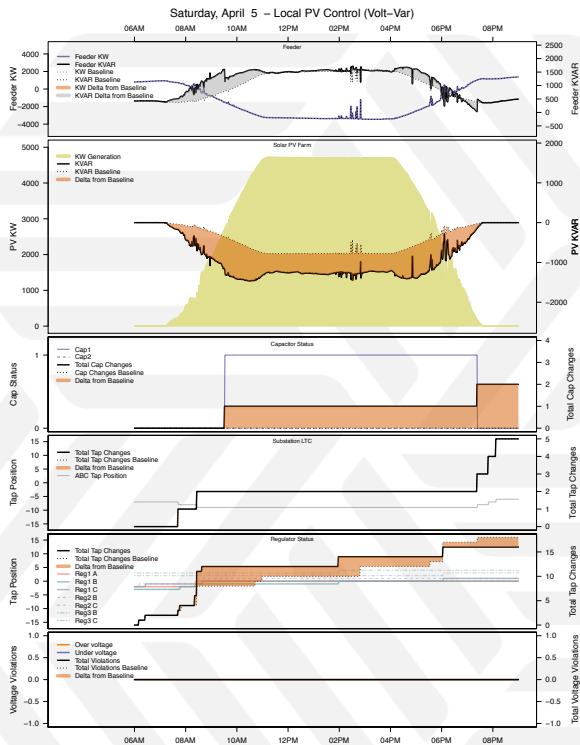

Legacy DMS Integrated Volt/VAR Control with LTC, VR and Caps Only

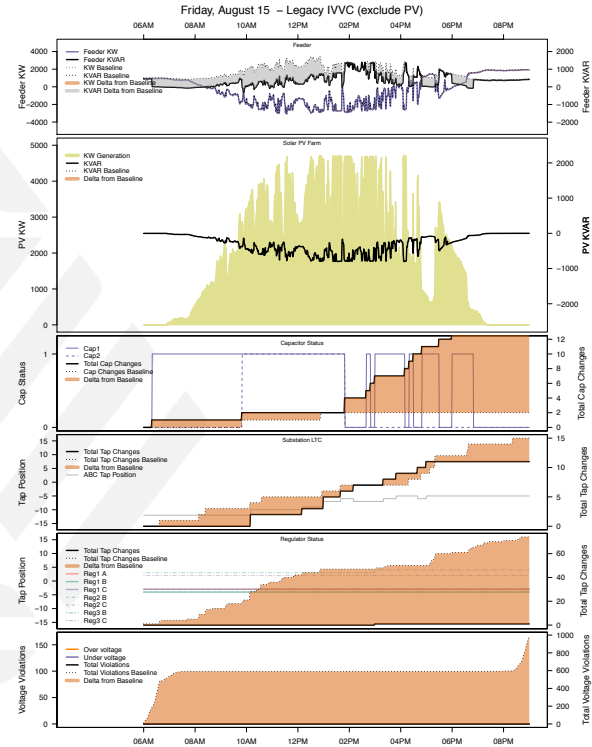
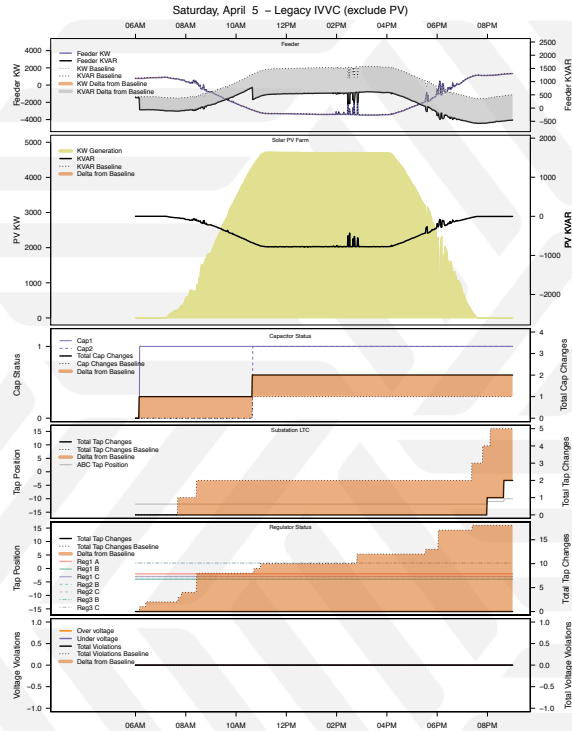

Integrating Advanced Inverters into IVVC

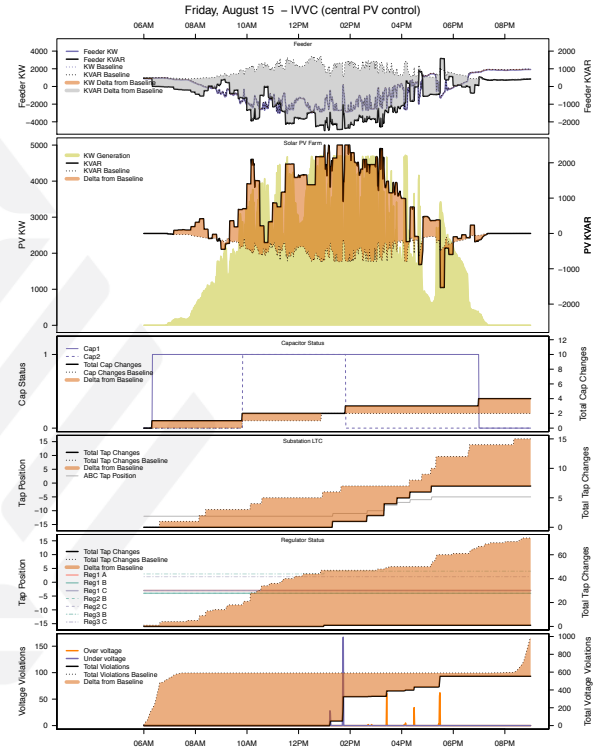
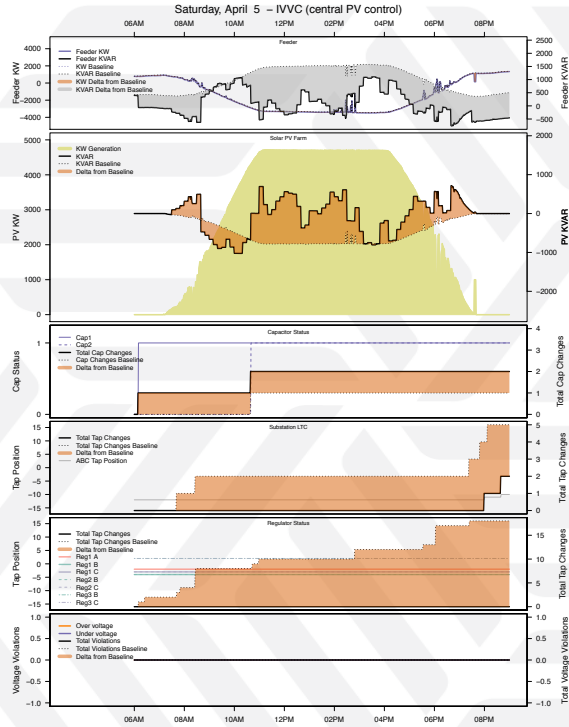

Feeder 40-day results of number of operations of voltage regulation equipment

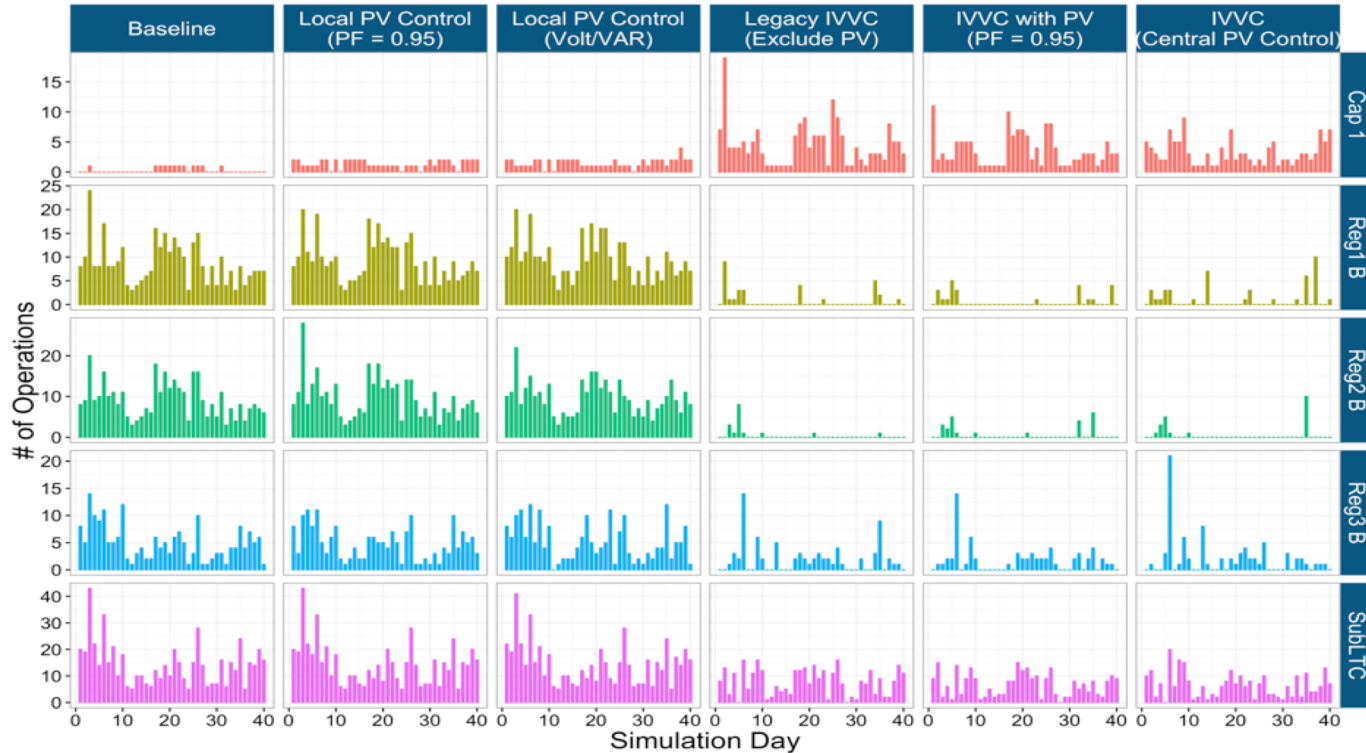

Feeder 40-day results of number of load-voltage violations

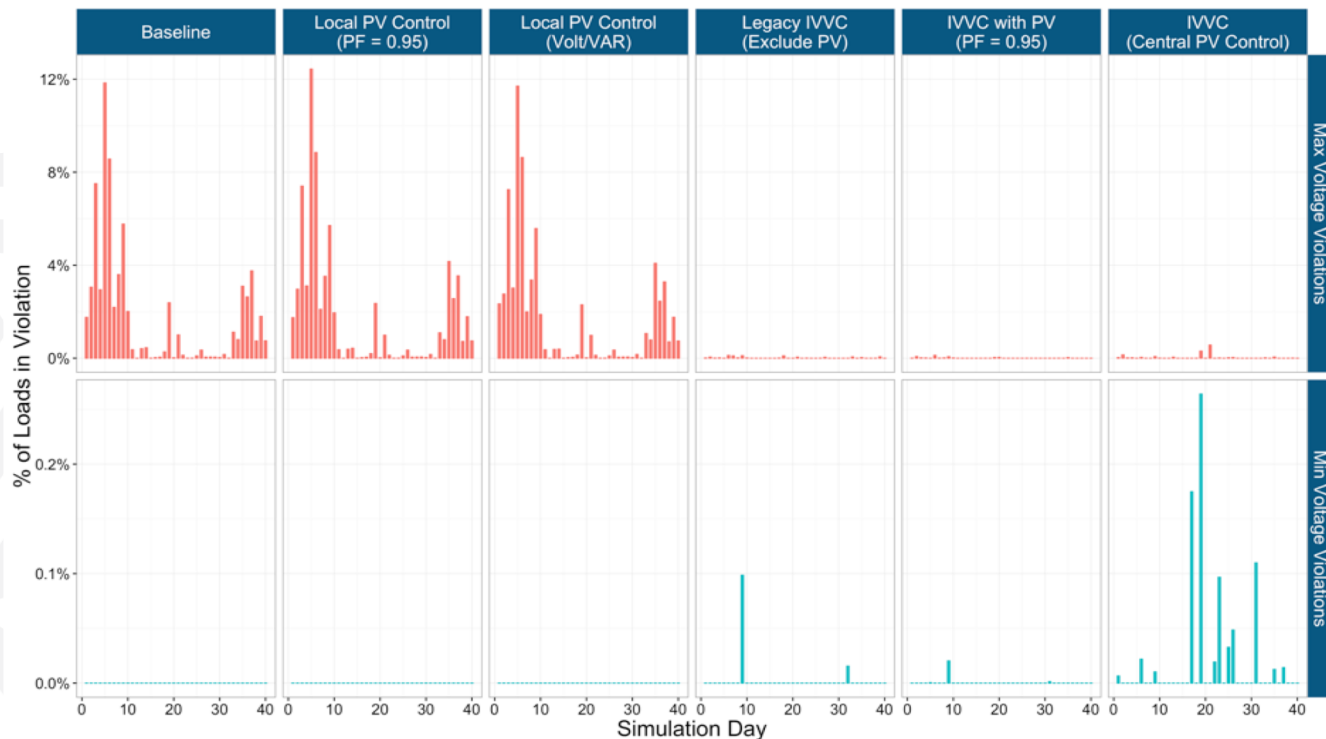

Summary Comparison of Annualized Scenarios

| Scenario | PV Mode | IVVC Control | | | | Annualized Equipment Operations | | | | Voltage Challenges | |
|-------------------------------------|-------------------------|--------------|------------|------------|----|---------------------------------|------------|------------|--------|--------------------|-------|
| | | LTC | Regulators | Capacitors | PV | LTC | Regulators | Capacitors | Total | Over | Under |
| Baseline | Default | - | - | - | - | 5,043 | 19,160 | 125 | 24,328 | 1.47% | 0.00% |
| Local PV Control (PF = 0.95) | PF=0.95 | - | - | - | - | 5,063 | 19,943 | 505 | 25,511 | 1.48% | 0.00% |
| Local PV Control (Volt/VAR) | Q(V) | - | - | - | - | 5,087 | 19,857 | 541 | 25,485 | 1.44% | 0.00% |
| Legacy IVVC (Exclude PV) | Default | Y | Y | Y | - | 2,869 | 2,943 | 1,863 | 7,675 | 0.02% | 0.00% |
| IVVC with PV (PF = 0.95) | PF=0.95 | Y | Y | Y | - | 2,498 | 1,888 | 1,409 | 5,795 | 0.01% | 0.00% |
| IVVC (Central PV Control) | IVVC for reactive power | Y | Y | Y | Y | 2,312 | 2,698 | 1,151 | 6,161 | 0.05% | 0.02% |

Case Study: Conclusion

- ▶ This work illustrates the potential for coordinated control of voltage management equipment, such as the central DMS-controlled IVVC by:
 - Providing substantial improvement in distribution operations with large-scale PV systems
 - Reducing regulator operations
 - Decreasing the number of voltage challenges
- ▶ The preliminary cost-benefit analysis (not detailed in this presentation) showed operational cost savings for the IVVC scenarios that were:
 - Partially driven by reduced wear and tear on utility regulating equipment,
 - Dominated by the use of CVR/Demand reduction objective
- ▶ Work needed in the area of integrating advanced inverters as controllable resources into IVVC optimization strategies
 - Event triggered operation of DMS IVVC
 - Power factor set point in place of reactive power set point

Thank you

Questions?